

CM, CME

Horizontal, multistage centrifugal pumps
50/60 Hz



Contents

General description

Introduction 4

Overview

Overview 6

Applications

Applications 7

Features and benefits

Features and benefits 9

Identification

Type key 10

Product range

Product range 11

Performance range

CM, 50 Hz 13

CM, 60 Hz 13

CME, 50/60 Hz 14

Operating conditions

Operating conditions 15

Pumped liquids

Pumped liquids 18

List of pumped liquids 18

Construction

Pump 21

Motor 21

Shaft seal 22

Pipe connections 22

Material specification 25

CME pumps

Communication with CME pumps 26

Speed control of CME pumps 27

Grundfos CUE

CM pumps connected to Grundfos CUE, external frequency converters 28

Certificates

CM and CME pumps with certificates 29

Selection and sizing

Selection of pumps 31

Selection of CME pumps 33

How to read the curve charts

Guidelines to performance curves 34

Performance curves, CM 50 Hz

CM 1 35

CM 3 36

CM 5 37

CM 10 38

CM 15 39

CM 25 40

Performance curves, CM 60 Hz

CM 1 41

CM 3 42

CM 5 43

CM 10 44

CM 15 45

CM 25 46

Performance curves, CME 50/60 Hz

CME 1 47

CME 3 48

CME 5 49

CME 10 50

CME 15 51

CME 25 52

Dimensions, CM 50 Hz

CM 1-A 53

CM 1-I and CM 1-G 54

CM 3-A 55

CM 3-I and CM 3-G 56

CM 5-A 57

CM 5-I and CM 5-G 58

CM 10-A 59

CM 10-I and CM 10-G 60

CM 15-A 61

CM 15-I and CM 15-G 62

CM 25-A 63

CM 25-I and CM 25-G 64

Contents

Dimensions, CM

60 Hz and 50/60 Hz

CM 1-A	65
CM 1-I and CM 1-G	66
CM 3-A	67
CM 3-I and CM 3-G	68
CM 5-A	69
CM 5-I and CM 5-G	70
CM 10-A	71
CM 10-I and CM 10-G	72
CM 15-A	73
CM 15-I and CM 15-G	74
CM 25-A	75
CM 25-I and CM 25-G	76

Dimensions, CME

60 Hz and 50/60 Hz

CME 1-A	77
CME 1-I and CME 1-G	78
CME 3-A	79
CME 3-I and CME 3-G	80
CME 5-A	81
CME 5-I and CME 5-G	82
CME 10-A	83
CME 10-I and CME 10-G	84
CME 15-A	85
CME 15-I and CME 15-G	86
CME 25-A	87
CME 25-I and CME 25-G	88

Weights and shipping volume

Weights and shipping volume	89
-----------------------------	----

Motor data

Mains-operated motors, 50 Hz	101
Mains-operated motors, 60 Hz	101
Mains-operated motors, 50/60 Hz	102
Speed-controlled motors	105
Additional data for speed-controlled motors	106

Accessories

Pipework connections	107
Potentiometer for CME	112
G10-LON interface for CME	112
LiqTec for CM and CME	112
R100 remote control	112
Sensors for CME	113
MP 204 motor protector	114

Customisation

Customisation	115
---------------	-----

Further product documentation

WebCAPS	116
WinCAPS	117

Introduction

The Grundfos CM and CME pumps are non-self-priming, horizontal, multistage, end-suction centrifugal pumps. The pumps are of the close-coupled type. CM pumps are fitted with mains-operated motors whereas the motor for CME pumps has an integrated frequency converter. Both CM and CME pumps have mechanical shaft seals.

The CM and CME pumps are available in these three material versions:

- Cast iron (EN-GJL-200)*
- Stainless steel (EN 1.4301/AISI 304)
- Stainless steel (EN 1.4401/AISI 316).

* The impeller, chamber and filling plugs are made of stainless steel (EN 1.4301/AISI 304).

The pump shaft is made of stainless steel (EN 1.4057/AISI 431).

CM

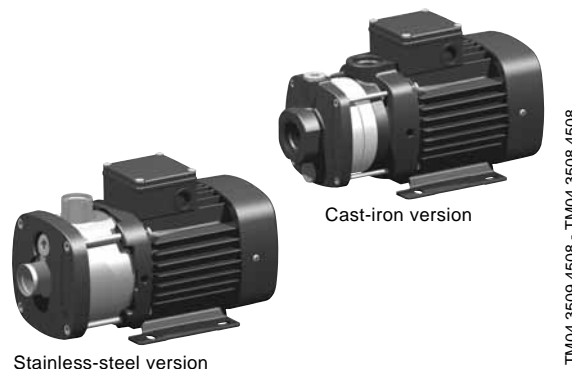

Fig. 1 Grundfos CM pumps

The CM pumps are unique products that have been developed in order to fulfil a wide variety of customer demands.

The CM pumps are available in various sizes and numbers of stages to provide the flow and pressure required.

The CM pumps consist of two main components: the motor and the pump unit.

The motor is a Grundfos motor designed to EN standards.

The pump unit incorporates optimised hydraulics and offers various types of connections.

The pumps offer many advantages, some of which are listed below and described in detail in *Features and benefits* on page 9:

- compact design
- worldwide usage
- high reliability
- service-friendly
- wide performance range
- low noise
- customised solutions.

CME

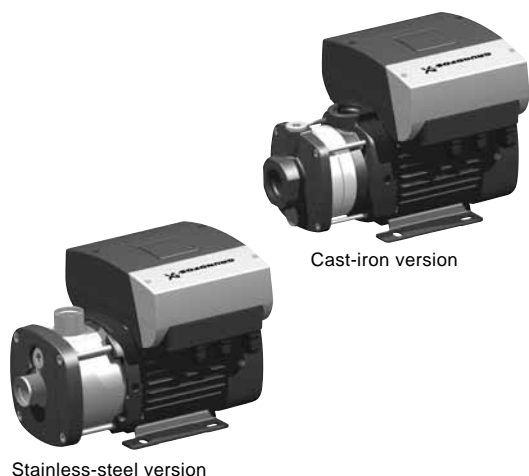

Stainless-steel version

Cast-iron version

TM04 3511 4508 - TM04 3510 4508

Fig. 2 Grundfos CME pumps

The CME pumps are built on the basis of CM pumps.

CME pumps belong to the so-called E-pump family.

The difference between the CM and the CME pump ranges is the motor.

The CME pump motor is a Grundfos MGE motor designed to EN standards. The motor incorporates a frequency converter.

Frequency control enables continuously variable control of the motor speed, which makes it possible to set the pump to operation at any duty point. The aim of continuously variable control of the motor speed is to adjust the performance to a given requirement.

It is possible to connect a pressure sensor to the built-in frequency converter on CME pumps. For further information, see *Sensors for CME* on page 113.

The pump materials are identical to those of the CM pump range.

Selecting a CME pump

Select a CME pump if the following features are required:

- controlled operation, i.e. consumption fluctuates
- constant pressure
- communication with the pump.

Adaptation of performance through frequency-controlled speed offers obvious benefits such as:

- energy savings
- increased comfort
- control and monitoring of the application and pump performance.

For further information about CME pumps, see *CME pumps* on page 26.

Overview



Applications

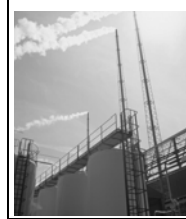

Pages 7 to 8

Identification



Page 10



Product range



Pages 11 to 12

Operating conditions

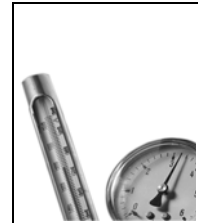

Pages 15 to 17

Construction



Pages 21 to 25

Pipe connections

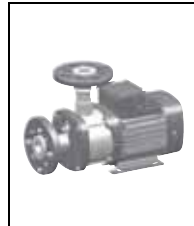

Page 22

Certificates and approvals

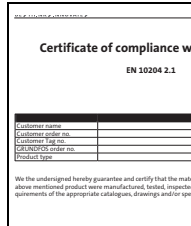

Pages 29 to 30

Selection and sizing

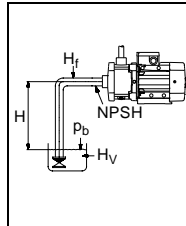

Pages 31 to 33

Performance curves

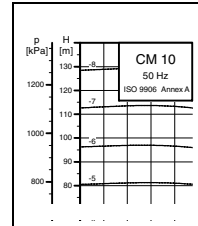

Pages 35 to 52

Dimensions

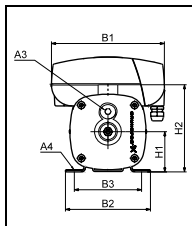

Pages 53 to 88

Motor data



Pages 101 to 106

Accessories



Pages 107 to 114

Customisation



Page 115

Further product information



Pages 116 to 117

Applications

The CM and CME pumps are designed to cover a wide variety of applications, ranging from small domestic installations to large industrial systems. The pumps are therefore suitable for a wide diversity of pumping systems where the performance and material of the pump must meet specific demands.

Some of the most typical applications are mentioned below:

- washing and cleaning
- water treatment
- temperature control
- pressure boosting.

Washing and cleaning



Fig. 3 Washing and cleaning

CM and CME pumps can be used in washing and cleaning applications, which usually involve pumping of water containing soap or other cleaning agents.

Reference applications

Typical washing and cleaning applications:

- degreasing and washing of production equipment in industrial environments such as the food and beverage industry
- washing machines
- vehicle-washing tunnels
- mobile-washing units
- units for CIP (Cleaning In Place).

Water treatment



Fig. 4 Water treatment

In water treatment plants, the water undergoes a process which makes it more suited for its end-use. In this process, the CM and CME pumps can be utilised either as feed pumps or as booster pumps.

Reference applications

Typical water treatment applications:

- nano-, micro- and ultra-filtration systems
- softening, ionising, demineralising systems
- desalination systems
- distillation systems
- separators
- swimming baths.

Temperature control

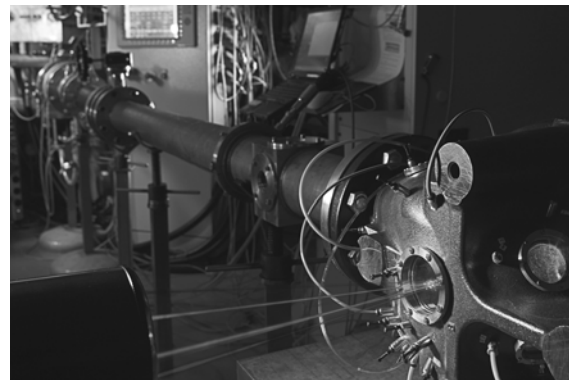

Fig. 5 Temperature control

Temperature control involves applications where the CM and CME pumps circulate a liquid in a closed loop consisting of a heating or cooling element for optimising a process by means of temperature. Temperature control is also chilling of equipment or food and beverage in the food production industry.

Reference applications

The CM and CME pumps can for example be used in temperature control systems such as:

- electronic data processing
- laser equipment
- medical equipment
- industrial refrigeration
- heating and cooling in industrial processes
- moisturising and humidifying.

To ensure safe and reliable operation in applications involving temperature control, we offer CM and CME pumps designed to meet your needs!

We provide solutions for applications involving pumping of these liquids:

- liquids at temperatures down to $-20\text{ }^{\circ}\text{C}$
- high-temperature liquids
- high-viscous liquids, etc.

Pumping of liquids at temperatures down to $-20\text{ }^{\circ}\text{C}^*$

When pumping liquids at temperatures down to $-20\text{ }^{\circ}\text{C}$ ($-30\text{ }^{\circ}\text{C}$)*, it is crucial that the pump parts are of the right materials and dimensions.

At such low temperatures, the selection of wrong materials and dimensions may cause deformation because of thermal expansion, and eventually stoppage of operation.

* CM and CME pumps for pumping liquids at temperatures below $-20\text{ }^{\circ}\text{C}$ are available on request. Please contact Grundfos.

Pumping of high-temperature liquids

The pumping of hot liquids such as water-based liquids up to $+120\text{ }^{\circ}\text{C}$ demands much of the pump parts, such as shaft seals and rubber parts.

Pumping of high-viscous liquids

In applications where high-viscous liquids are pumped, the motor of the pump can be overloaded, and the pump performance will be reduced.

The viscosity of a pumped liquid depends strongly on the pumped liquid and its temperature.

To meet the above-mentioned requirements, we offer CM and CME pumps with oversize motors.

Pressure boosting



Fig. 6 Pressure boosting

In pressure-boosting applications, the pumped liquid must be delivered at a desired pressure on demand. The main priorities in pressure-boosting applications are to ensure maximum reliability and user comfort. Therefore, the CM and CME pumps are also ideal for such applications.

Reference applications

Typical pressure-boosting applications:

- pressure boosting and transfer of drinking water
- process-water systems.

Other applications

Besides the applications mentioned above, the CM and CME pumps can be used in many other applications. Examples:

- distilling systems
- dosing / mixing
- evaporation
- comprised machinery
- chemical industry
- pharmaceutical industry.

Features and benefits

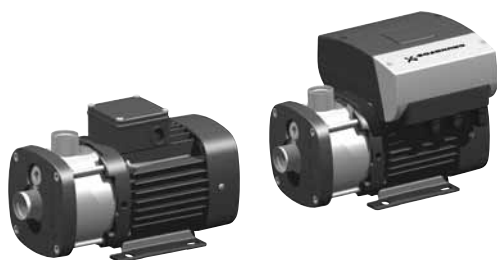

TM04 3508 4508 - TM04 3511 4508

Fig. 7 CM and CME pumps

CM and CME pumps present the following features and benefits:

Compact design

Pump and motor are integrated in a compact and user-friendly design. The pump is fitted to a low-profile base plate, making it ideal for installation in systems where compactness is important.

Modular construction/customised solutions

The modular construction of the CM and CME pumps makes it easy to create many different variants based on standard factory parts. This means that it is possible to create pump variants that are customised for the application in question.

Worldwide usage

- With different voltage and frequency combinations, the CM and CME product ranges cover markets worldwide.
- Various certificates covering worldwide usage are available. See *Certificates* on page 29.

High reliability

- New state-of-the-art shaft seal design and materials offering these benefits:
 - high wear resistance and long operating life
 - improved sticking and dry-running capabilities.
- The pumps are less sensitive to impurities in the pumped liquid than similar pumps of the canned-rotor type.

Easy installation and commissioning

- A non-verbal Quick Guide is supplied with each CM pump, which enables easy installation and commissioning. Detailed multilingual installation and operating instructions are supplied with each pump.
- An installation indicator is fitted on three-phase pumps, which makes it easy to see if the electrical connection of the motor is correct. Based on the motor cooling air, it indicates the direction of rotation of the motor.

Service-friendly

- Service was in mind during the development.
- No special service tools required.
- Spare parts in stock for quick delivery.
- All parts available as kits, single parts or bulks.
- Service instructions and video make it simple to disassemble and assemble the pump.
- Service kit instructions available where estimated necessary.

Wide performance range

- Can be used in a wide range of applications:
 - washing and cleaning
 - water treatment
 - temperature control
 - pressure boosting
 - chemical industry
 - pharmaceutical industry
 - etc.
- Product range in WinCAPS and WebCAPS. See *Further product documentation* on page 116.

Low noise level

The CM and CME pumps offer very silent operation.

High-performance hydraulics

Pump efficiency is maximised by the optimised hydraulics and carefully crafted production technology.

Electro-coated cast-iron parts

- Optimised corrosion resistance
- Better efficiency because of smooth surfaces.

Customised solutions

It is possible to create many different variants of the CM and CME pumps. For further information, see *Customisation* on page 115.

- Motor adaptation
- Pump body modifications.

Grundfos motor

Grundfos motors are remarkably silent and highly efficient.

Grundfos motors are available with integrated frequency converter designed for speed-controlled operation.

Data and literature about the CM and CME pumps

All literature and technical data related to CM and CME pumps are available on line in Grundfos WebCAPS.

Type key

CM, CME

Example	CME	10	-	8	A	-	R	-	A	-	E	-	A	V	B	E	X	-	X	-	X	-	X	
Type range CM: Centrifugal Modular CME: Centrifugal Modular with integrated frequency converter																								Sensor Sensor designation
Rated flow Rated flow at 50 Hz [m ³ /h]																								Mains plug A: Cable glands B: Harting plug C: With cable
Number of impellers																								Motor information A: Standard motor (IP55) B: Phase-insulated motor for use with frequency converter C: IP54 D: Pt100 in stator E: Angular contact bearing F: Motor heater G: Three-phase motor with overload protection H: Single-phase motor with no protection
Pump version A: Basic version B: Oversize motor (one flange size larger) E: Pumps with certificates and other approvals HS: High-pressure pump with high-speed MGE motor I: Altered pressure class J: Pump with a different maximum speed M: Magnet-driven pump N: CME pump with sensor (see code for "Sensor") P: Undersize motor (one flange size smaller) T: Oversize motor (two flange sizes larger) V: CME pump for Multi-E X: Special pump																								Supply voltage A: 1 x 220 V, 60 Hz B: 1 x 115/230 V, 60 Hz C: 1 x 220-240 V, 50 Hz D: 1 x 127 V, 60 Hz E: 3 x 208-230/440-480 V, 60 Hz F: 3 x 220-240/380-415 V, 50 Hz G: 3 x 200/346 V, 50 Hz; 200-220/346-380 V, 60 Hz H: 3 x 575 V, 60 Hz I: 3 x 400 V, 50/60 Hz J: 3 x 380-415 V, 50 Hz; 440-480 V, 60 Hz K: 1 x 220-240 V, MGE motor L: 3 x 380-480 V, MGE motor M: 1 x 208-230 V, MLE motor N: 3 x 460-480 V, MLE motor O: 3 x 220-240/380-415 V, 50 Hz 3 x 220-255/380-440 V, 60 Hz
Pipe connection C: Tri-Clamp® F: DIN flange G: ANSI flange J: JIS flange P: PJE coupling R: Whitworth thread Rp (ISO 7/1) S: Internal NPT thread																								Material of secondary seal E: EPDM (ethylene propylene) K: FFKM (perflour) V: FKM (flour)
Materials in contact with pump media A: Suction and discharge parts EN-GJL-200 Pump shaft EN 1.4057/AISI 431 Impellers/chambers EN 1.4301/AISI 304 G: Sleeve EN 1.4401/AISI 316 Pump shaft EN 1.4401/AISI 316 Impellers/chambers EN 1.4401/AISI 316 I: Sleeve EN 1.4301/AISI 304 Pump shaft EN 1.4301/AISI 304 Impellers/chambers EN 1.4301/AISI 304 X: Special version																								Material of stationary seal face B: Carbon, synthetic resin-impregnated Q: Silicon carbide (SiC)
Rubber parts in pump (excl. neck ring and shaft seal) E: EPDM (ethylene propylene) K: FFKM (perflour) V: FKM (flour)																								Material of rotating seal face Q: Silicon carbide (SiC) V: Aluminium oxide (Al2O3)
Note: Gaskets between chambers for cast-iron versions are always made of Tesnit BA-U.																								Shaft seal type designation A: O-ring seal with fixed driver

Note: The type key cannot be used for ordering as not all combinations are possible.

Product range

Pump type	50 Hz		60 Hz		Shaft seal					Mains-operated motor			Electronically speed-controlled motor														
	Material		Material							50 Hz	60 Hz	50/60 Hz	Voltage [V]														
					Voltage [V]	Voltage [V]	Voltage [V]	Voltage [V]																			
					Voltage [V]	Voltage [V]	Voltage [V]	Voltage [V]																			
	Cast iron, EN-GJL-200 (CM-A)	Stainless steel, EN 1.4301/AISI 304 (CM-I)	Stainless steel, EN 1.4401/AISI 316 (CM-G)	Cast iron, EN-GJL-200 (CM-A)	Stainless steel, EN 1.4301/AISI 304 (CM-I)	Stainless steel, EN 1.4401/AISI 316 (CM-G)	AVBE	AVBV	AQQE	AQQV	AQKQ	1 x 220-240 V (supply voltage C)	3 x 220-240 V/380-415 V (supply voltage F)	1 x 220 V (supply voltage A)	1 x 115/230 V (supply voltage B)	1 x 127 V ¹⁾ (supply voltage D)	3 x 208-230 V/440-480 V (supply voltage E)	3 x 575 V (supply voltage H)	3 x 220-240 V/380-415 V, (50 Hz)/ 3 x 220-255 V/380-440 V, (60 Hz) (supply voltage O)	3 x 380-415 V, (50 Hz)/ 3 x 440-480 V, (60 Hz) (supply voltage J)	3 x 200 V/346 V, (50 Hz); 3 x 200-220 V/346-380 V, (60 Hz) (supply voltage G)	3 x 400 V (50/60 Hz) (supply voltage I)	3 x 380-480 V (50/60 Hz) (supply voltage L)	1 x 220-240 V (50/60 Hz) (supply voltage K)	3 x 460-480 V (60 Hz) (supply voltage N)	1 x 208-230 V (50/60 Hz) (supply voltage M)	
CM 1-2	●	●	●	●	●	●	●	●	●	●	●	●	●	●	●	●	●	●	●	●	●	●	●	●	●	●	●
CM 1-3	●	●	●	●	●	●	●	●	●	●	●	●	●	●	●	●	●	●	●	●	●	●	●	●	●	●	●
CM 1-4	●	●	●	●	●	●	●	●	●	●	●	●	●	●	●	●	●	●	●	●	●	●	●	●	●	●	●
CM 1-5	●	●	●	●	●	●	●	●	●	●	●	●	●	●	●	●	●	●	●	●	●	●	●	●	●	●	●
CM 1-6	●	●	●	●	●	●	●	●	●	●	●	●	●	●	●	●	●	●	●	●	●	●	●	●	●	●	●
CM 1-7	●	●	●	●	●	●	●	●	●	●	●	●	●	●	●	●	●	●	●	●	●	●	●	●	●	●	●
CM 1-8	●	●	●	●	● ²⁾	● ²⁾	●	●	●	●	●	●	●	●	●	●	●	●	●	●	●	●	●	●	●	●	●
CM 1-9	●	●	●	●	● ²⁾	● ²⁾	●	●	●	●	●	●	●	●	●	●	●	●	●	●	●	●	●	●	●	●	●
CM 1-10	●	●	●	●	● ²⁾	● ²⁾	●	●	●	●	●	●	●	●	●	●	●	●	●	●	●	●	●	●	●	●	●
CM 1-11	●	●	●	●	●	●	● ³⁾	● ³⁾	● ³⁾	●	●	●	●	●	●	●	●	●	●	●	●	●	●	●	●	●	●
CM 1-12	●	●	●	●	●	●	● ³⁾	● ³⁾	● ³⁾	●	●	●	●	●	●	●	●	●	●	●	●	●	●	●	●	●	●
CM 1-13	●	●	●	●	●	●	● ³⁾	● ³⁾	● ³⁾	●	●	●	●	●	●	●	●	●	●	●	●	●	●	●	●	●	●
CM 1-14	●	●	●	●	●	●	● ³⁾	● ³⁾	● ³⁾	●	●	●	●	●	●	●	●	●	●	●	●	●	●	●	●	●	●
CM 3-2	●	●	●	●	●	●	●	●	●	●	●	●	●	●	●	●	●	●	●	●	●	●	●	●	●	●	●
CM 3-3	●	●	●	●	●	●	●	●	●	●	●	●	●	●	●	●	●	●	●	●	●	●	●	●	●	●	●
CM 3-4	●	●	●	●	●	●	●	●	●	●	●	●	●	●	●	●	●	●	●	●	●	●	●	●	●	●	●
CM 3-5	●	●	●	●	●	●	●	●	●	●	●	●	●	●	●	●	●	●	●	●	●	●	●	●	●	●	●
CM 3-6	●	●	●	●	●	●	●	●	●	●	●	●	●	●	●	●	●	●	●	●	●	●	●	●	●	●	●
CM 3-7	●	●	●	●	●	●	●	●	●	●	●	●	●	●	●	●	●	●	●	●	●	●	●	●	●	●	●
CM 3-8	●	●	●	●	● ²⁾	● ²⁾	●	●	●	●	●	●	●	●	●	●	●	●	●	●	●	●	●	●	●	●	●
CM 3-9	●	●	●	●	● ²⁾	● ²⁾	●	●	●	●	●	●	●	●	●	●	●	●	●	●	●	●	●	●	●	●	●
CM 3-10	●	●	●	●	● ²⁾	● ²⁾	●	●	●	●	●	●	●	●	●	●	●	●	●	●	●	●	●	●	●	●	●
CM 3-11	●	●	●	●	●	●	● ³⁾	● ³⁾	● ³⁾	●	●	●	●	●	●	●	●	●	●	●	●	●	●	●	●	●	●
CM 3-12	●	●	●	●	●	●	● ³⁾	● ³⁾	● ³⁾	●	●	●	●	●	●	●	●	●	●	●	●	●	●	●	●	●	●
CM 3-13	●	●	●	●	●	●	● ³⁾	● ³⁾	● ³⁾	●	●	●	●	●	●	●	●	●	●	●	●	●	●	●	●	●	●
CM 3-14	●	●	●	●	●	●	● ³⁾	● ³⁾	● ³⁾	●	●	●	●	●	●	●	●	●	●	●	●	●	●	●	●	●	●

¹⁾ On request.

²⁾ Not suitable for 60 Hz mains-operated pumps, nor CME pumps running at 100 % speed.

³⁾ Not suitable for pumping liquids at temperatures above +90 °C.

Pump type	50 Hz		60 Hz		Shaft seal					Mains-operated motor			Electronically speed-controlled motor		
	Material		Material							50 Hz	60 Hz		50/60 Hz		Voltage [V]
					Voltage [V]	Voltage [V]		Voltage [V]							
	Cast iron, EN-GJL-200 (CM-A)														
	Stainless steel, EN 1.4301/AISI 304 (CM-I)														
	Stainless steel, EN 1.4401/AISI 316 (CM-G)														
	Cast iron, EN-GJL-200 (CM-A)														
	Stainless steel, EN 1.4301/AISI 304 (CM-I)														
	Stainless steel, EN 1.4401/AISI 316 (CM-G)														
					AVBE										
					AVBV										
					AQQE										
					AQQV										
					AQOK										
										1 x 220-240 V (supply voltage C)					
										3 x 220-240 V/380-415 V (supply voltage F)					
										1 x 220 V (supply voltage A)					
										1 x 115/230 V (supply voltage B)					
										1 x 127 V ¹⁾ (supply voltage D)					
										3 x 208-230 V/440-480 V (supply voltage E)					
										3 x 575 V (supply voltage H)					
										3 x 220-240 V/380-415 V, (50 Hz)/					
										3 x 220-255 V/380-440 V, (60 Hz) (supply voltage O)					
										3 x 380-415 V, (50 Hz)/					
										3 x 440-480 V, (60 Hz) (supply voltage J)					
										3 x 200 V/346 V, (50 Hz);					
										3 x 200-220 V/346-380 V, (60 Hz) (supply voltage G)					
										3 x 400 V (50/60 Hz) (supply voltage I)					
										3 x 380-480 V (50/60 Hz) (supply voltage L)					
										1 x 220-240 V (50/60 Hz) (supply voltage K)					
										3 x 460-480 V (60 Hz) (supply voltage N)					
										1 x 208-230 V (50/60 Hz) (supply voltage M)					
CM 5-2	●	●	●	●	●	●	●	●	●	●	●	●	●	●	●
CM 5-3	●	●	●	●	●	●	●	●	●	●	●	●	●	●	●
CM 5-4	●	●	●	●	●	●	●	●	●	●	●	●	●	●	●
CM 5-5	●	●	●	●	●	●	●	●	●	●	●	●	●	●	●
CM 5-6	●	●	●	●	●	●	●	●	●	●	●	●	●	●	●
CM 5-7	●	●	●	●	●	●	●	●	●	●	●	●	●	●	●
CM 5-8	●	●	●	●	● ²⁾	● ²⁾	●	●	●	●	●	●	●	●	●
CM 5-9			●		● ²⁾	● ²⁾	●	●	●	●	●	●	●	●	●
CM 5-10			●		● ²⁾	● ²⁾	●	●	●	●	●	●	●	●	●
CM 5-11							● ³⁾	● ³⁾	● ³⁾	●	●	●	●	●	●
CM 5-12			●				● ³⁾	● ³⁾	● ³⁾	●	●	●	●	●	●
CM 5-13			●				● ³⁾	● ³⁾	● ³⁾	●	●	●	●	●	●
CM 10-1	●	●	●	●	●	●	●	●	●	●	●	●	●	●	●
CM 10-2	●	●	●	●	●	●	●	●	●	●	●	●	●	●	●
CM 10-3	●	●	●	●	●	●	●	●	●	●	●	●	●	●	●
CM 10-4	●	●	●	●	●	●	●	●	●	●	●	●	●	●	●
CM 10-5	●	●	●	●	● ²⁾	● ²⁾	●	●	●	●	●	●	●	●	●
CM 10-6			●		● ²⁾	● ²⁾	●	●	●	●	●	●	●	●	●
CM 10-7			●				● ³⁾	● ³⁾	● ³⁾	●	●	●	●	●	●
CM 10-8			●				● ³⁾	● ³⁾	● ³⁾	●	●	●	●	●	●
CM 15-1	●	●	●	●	●	●	●	●	●	●	●	●	●	●	●
CM 15-2	●	●	●	●	●	●	●	●	●	●	●	●	●	●	●
CM 15-3	●	●	●	●	●	●	●	●	●	●	●	●	●	●	●
CM 15-4	●	●	●	●	● ²⁾	● ²⁾	●	●	●	●	●	●	●	●	●
CM 25-1	●	●	●	●	●	●	●	●	●	●	●	●	●	●	●
CM 25-2	●	●	●	●	●	●	●	●	●	●	●	●	●	●	●
CM 25-3	●	●	●	●	● ²⁾	● ²⁾	●	●	●	●	●	●	●	●	●
CM 25-4	●	●	●	●	● ²⁾	● ²⁾	●	●	●	●	●	●	●	●	●

¹⁾ On request.

²⁾ Not suitable for 60 Hz mains-operated pumps nor CME pumps running at 100% speed.

³⁾ Not suitable for pumping liquids above +90 °C.

CM, 50 Hz

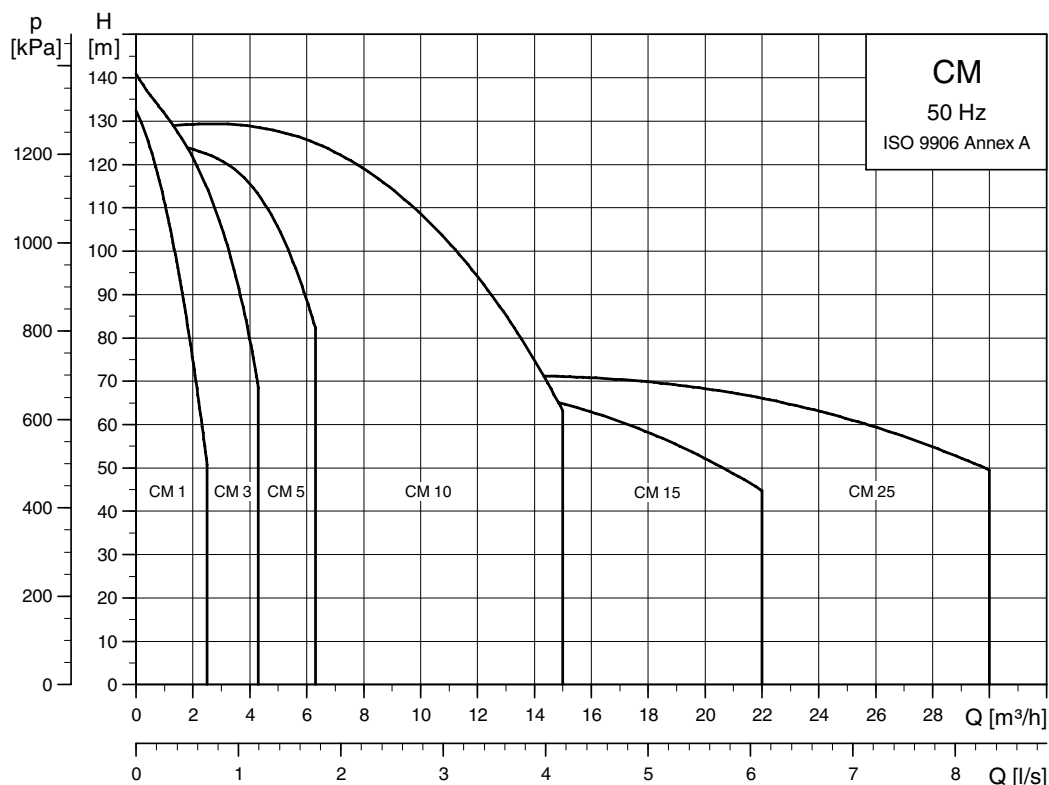

TM04 3340 4308

CM, 60 Hz

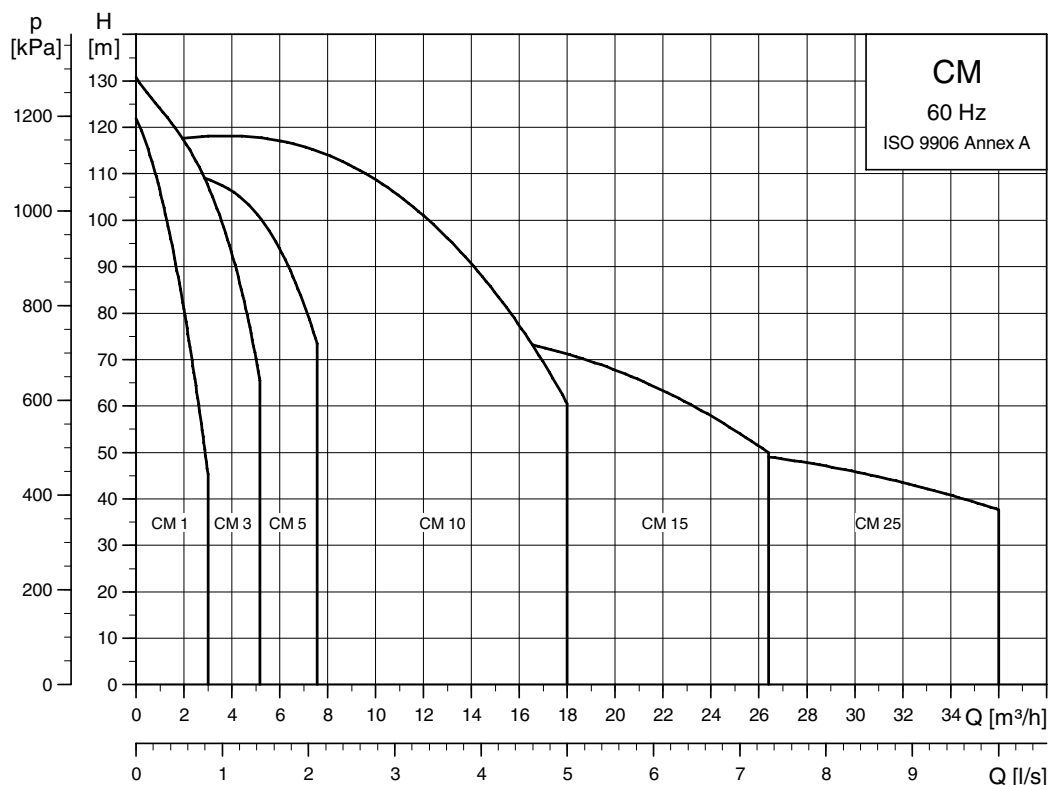

TM04 3369 4308

CME, 50/60 Hz

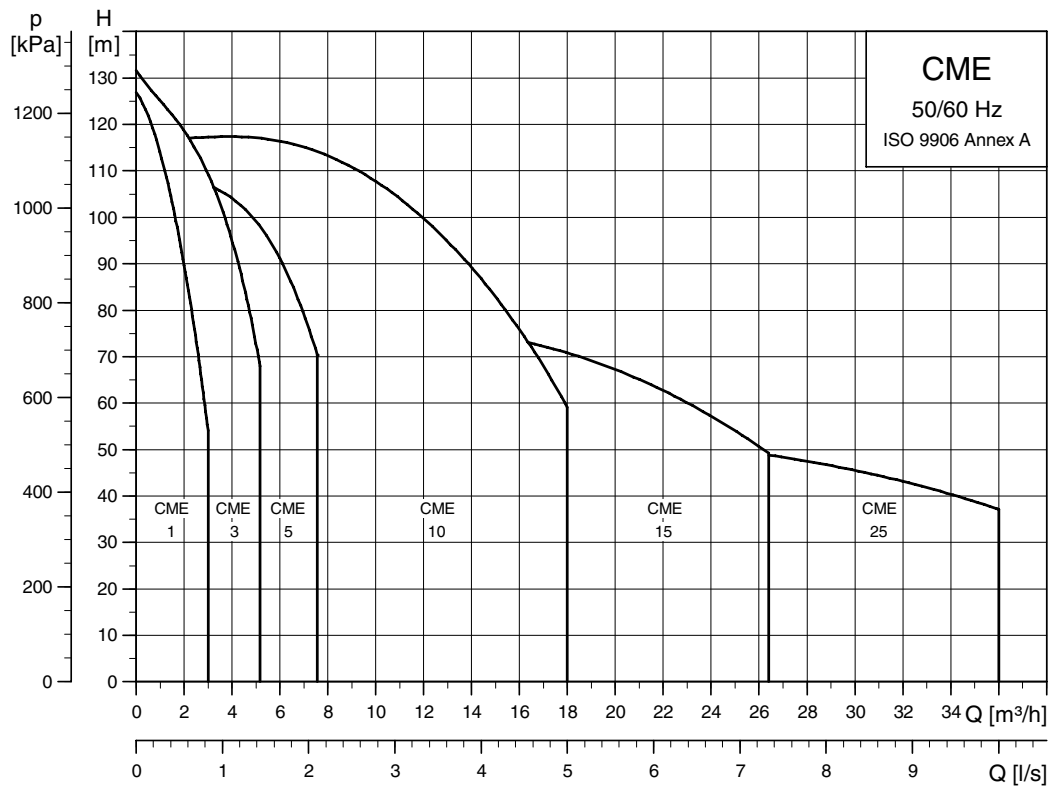

TM04 3568 4608

Operating conditions

Ambient temperature

Maximum ambient temperature in relation to liquid temperature

The maximum ambient temperature depends on the liquid temperature as shown in the table below.

Maximum ambient temperature	Liquid temperature
+55 °C*	+90 °C
+50 °C*	+100 °C
+45 °C*	+110 °C
+40 °C	+120 °C

* The maximum ambient temperature for CME pumps is +40 °C, irrespective of the liquid temperature.

Derating of motor output (P_2) in relation to ambient temperature and altitude above sea level

If the ambient temperature exceeds +40 °C for CME pumps or +55 °C for CM pumps, or if the motor is installed more than 1000 metres above sea level, the motor output (P_2) must be reduced due to the low density and consequently low cooling effect of the air. In such cases, it may be necessary to use an oversize motor with higher rated output. Figure 8 shows the relationship between motor output (P_2) and ambient temperature or motor output (P_2) and altitude. The x-axis showing the temperature corresponds to an altitude of 1000 metres above sea level. The x-axis showing the altitude corresponds to an ambient temperature of +40 °C.

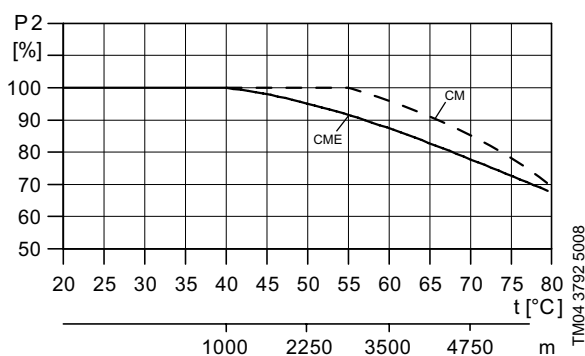

Fig. 8 Relationship between motor output (P_2) and temperature or motor output (P_2) and altitude

Storage and transport temperature

−40 °C to +60 °C.

Maximum operating pressure and permissible liquid temperature

The maximum operating pressure and the permissible liquid temperature depend on the pump material, the type of shaft seal and the pumped liquid.

Material variant	Shaft seal	Permissible liquid temperature*	Maximum operating pressure
Cast iron (EN-GJL-200)	AVBx	−20 °C to +40 °C +41 °C to +90 °C	10 bar 6 bar
	AQQx	−20 °C to +90 °C	10 bar
Stainless steel (EN 1.4301/AISI 304)	AVBx	−20 °C to +40 °C +41 °C to +90 °C	10 bar 6 bar
	AQQx	−20 °C*** to +90 °C +91 °C*** to +120 °C**	16 bar 10 bar
Stainless steel (EN 1.4401/AISI 316)	AVBx	−20 °C to +40 °C +41 °C to +90 °C	10 bar 6 bar
	AQQx	−20*** °C to +90 °C +91 °C to +120 °C**	16 bar 10 bar

* At liquid temperatures below 0 °C (32 °F), higher motor outputs may be needed due to increased viscosity, for instance if glycol has been added to the water.

** 120 °C applies only if the pump has an AQQE shaft seal.

*** CM and CME pumps for liquid temperatures below −20 °C are available on request. Please contact Grundfos.

Liquid temperature range

O-ring material / liquid	Permissible liquid temperature
EPDM	−20 °C to +120 °C
FFKM	−20 °C to +120 °C
FKM / liquids containing water	−20 °C to +90 °C
FKM / oil without water	0 °C to +120 °C

Operating range of the shaft seal

The operating range of the shaft seal depends on operating pressure, type of shaft seal and liquid temperature.

The curve in fig. 9 shows which shaft seals are suitable at a given temperature and a given pressure.

The curve applies to clean water.

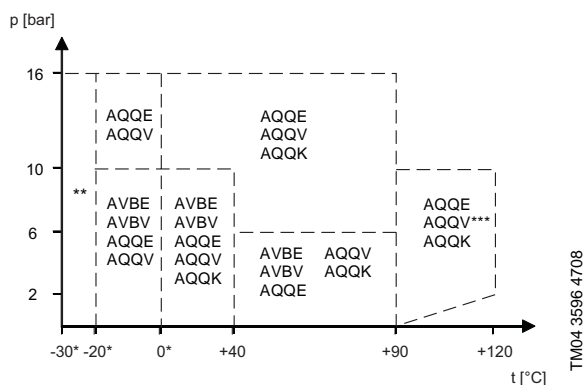

Fig. 9 Curve for the selection of shaft seals

- * Antifreeze should be added at liquid temperatures below 0 °C.
- ** CM and CME pumps for liquid temperatures below -20 °C are available on request. Please contact Grundfos.
- *** AQQV above +90 °C only in media not containing water.

Viscosity

The pumping of liquids with densities or kinematic viscosities higher than those of water will cause a considerable pressure drop, a drop in the hydraulic performance and a rise in the power consumption.

For instance at liquid temperatures below 0 °C (32 °F), higher motor outputs may be needed due to increased viscosity if glycol has been added to the water.

In such situations, the pump should be fitted with a larger motor. If in doubt, contact Grundfos or visit WebCAPS. See page 116.

Sound pressure level

The sound pressure values in the table below apply for CM pumps. If the motor output (P_2) for a given CM pump is not found in the table, use the nearest rounded-up value. The values for sound pressure include a tolerance of 3 dB[A] according to EN ISO 4871.

P_2 [kW]	50 Hz	60 Hz
	\bar{L}_{pA} [dB(A)]	\bar{L}_{pA} [dB(A)]
0.37	50	55
0.55	50	53
0.75	50	54
1.1	52	57
1.5	54	59
2.2	54	59
3.0	55	60
4.0	62	66
5.5	60	65
7.5	60	65
11.0	60	65

The audible noise from CM pumps is primarily noise from the motor fan. The selection of CME pumps will reduce the noise at partial load, as the motor, and consequently, the motor fan runs at a lower speed. Possible flow noise from control valves is also reduced at partial load in the case of the CME pump.

Minimum inlet pressure, NPSH

Calculation of the inlet pressure "H" is recommended in these situations:

- The liquid temperature is high.
- The flow is significantly higher than the rated flow.
- Water is drawn from depths.
- Water is drawn through long pipes.
- Inlet conditions are poor.

To avoid cavitation, make sure that there is a minimum pressure on the suction side of the pump. The maximum suction lift "H" in metres head can be calculated as follows:

$$H = p_b \times 10.2 - \text{NPSH} - H_f - H_v - H_s$$

p_b = Barometric pressure in bar.
(Barometric pressure can be set to 1 bar).
In closed systems, p_b indicates the system pressure in bar.

NPSH = Net Positive Suction Head in metres head.
(To be read from the NPSH curve at the highest flow the pump will be delivering).

H_f = Friction loss in suction pipe in metres head.
(At the highest flow the pump will be delivering).

H_v = Vapour pressure in metres head.
(To be read from the vapour pressure scale.
" H_v " depends on the liquid temperature " T_m ").

H_s = Safety margin = minimum 0.5 metres head.

If the "H" calculated is positive, the pump can operate at a suction lift of maximum "H" metres head.

If the "H" calculated is negative, an inlet pressure of minimum "H" metres head is required.

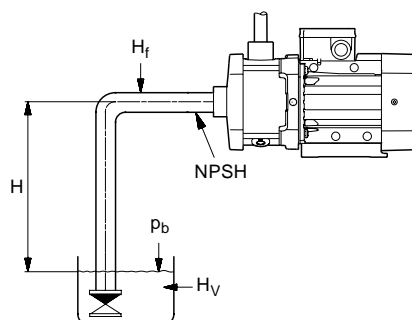

Fig. 10 Minimum inlet pressure (NPSH)

Note: To avoid cavitation, **never** select a pump with a duty point too far to the right on the NPSH curve.

Always check the NPSH value of the pump at the highest possible flow.

TM04 3487 4508

Pumped liquids

Thin, non-explosive liquids, not containing solid particles or fibres. The liquid must not chemically attack the pump materials.

When pumping liquids with a density and/or viscosity higher than those of water, oversized motors must be used, if required.

Whether a pump is suitable for a particular liquid depends on a number of factors of which the most important are the chloride content, pH value, temperature and content of chemicals and oils.

Please note that aggressive liquids (for instance seawater and some acids) may attack or dissolve the protective oxide film of the stainless steel and thus cause corrosion.

List of pumped liquids

A number of typical liquids are listed below.

Other pump versions may be applicable, but those stated in the list are considered to be the best choices.

The table is intended as a general guide only and cannot replace actual testing of the pumped liquids and pump materials under specific working conditions.

The list should, however, be applied with some caution as factors such as concentration of the pumped liquid, liquid temperature or pressure may affect the chemical resistance of a specific pump version.

Safety precautions must be taken when pumping dangerous liquids.

Notes

a	May contain additives or impurities which can cause shaft seal problems.
b	The density and viscosity may differ from those of water. Consider this when calculating motor and pump performance.
c	In order to avoid corrosion, the liquid must be free of oxygen. Flammable or combustible liquid. Safety precautions must be considered to ensure safe handling of flammable liquids. Handling the liquid above the flash point and/or boiling point will require the greatest restrictions. A seal-less pump may be required. Contact Grundfos..
d	Risk of crystallisation/precipitation on the shaft seal.
f	If oil residues are present, EPDM cannot be used.

Pumped liquids	Notes	Additional information	Cast iron (EN-GJL-200)	Stainless steel (EN 1.4301/AISI 304)	Stainless steel (EN 1.4401/AISI 316)
Water					
Boiler feed water			AVBE/AQQE	AVBE/AQQE	AVBE/AQQE
Brackish water	a	30 °C, 2000 ppm chloride			AVBE/AQQE
Condensate			AVBE/AQQE	AVBE/AQQE	AVBE/AQQE
Cooling and cutting lubricant	b		AQQV	AQQV	AQQV
Groundwater		< 300 ppm chloride	AVBE/AQQE	AVBE/AQQE	AVBE/AQQE
Demineralised water		< 2 microS/cm (> 0.5 Meg)	AQQE	AQQE	AQQE
Demineralised water		> 2 microS/cm (< 0.5 Meg)	AVBE	AVBE	AVBE
District heating water			AVBE/AQQE	AVBE/AQQE	AVBE/AQQE
Oil-containing water			AVBV/AQQV	AVBV/AQQV	AVBV/AQQV
Softened water			AVBE/AQQE	AVBE/AQQE	AVBE/AQQE
Swimming pool water, chlorinated		40 °C, 150 ppm chloride, < 2 ppm free chlorine	AVBE/AQQE	AVBE/AQQE	AVBE/AQQE
Coolants					
Calcium chloride	b, c, d, f	< 0 °C, 30 %		AQQE	AQQE
Ethylene glycol	b, c	< 50 °C	AQQE	AQQE	AQQE
Glycerine (glycerol)	b, c	< 50 °C	AQQE	AQQE	AQQE
Hydrocarbon-based coolant	c, e	50 °C	AQQV	AQQV	AQQV
Potassium acetate (inhibited)	b, c, d, f	< 20 °C	AQQE	AQQE	AQQE
Potassium formate (inhibited)	b, c, d, f	< 20 °C	AQQE	AQQE	AQQE
Propylene glycol	b, c	< 50 °C	AQQE	AQQE	AQQE
Sodium chloride	b, c, d, f	< 0 °C, 30 %		AQQE	AQQE
Fuels					
Diesel oil	e		AVBV/AQQV	AVBV/AQQV	AVBV/AQQV
Jet fuel	e		AVBV/AQQV	AVBV/AQQV	AVBV/AQQV
Kerosene	e		AVBV/AQQV	AVBV/AQQV	AVBV/AQQV
Naphta	e		AVBV/AQQV	AVBV/AQQV	AVBV/AQQV
Petrol	e		AVBV/AQQV	AVBV/AQQV	AVBV/AQQV
Biodiesel	e		AVBV/AQQV	AVBV/AQQV	AVBV/AQQV

Pumped liquids

CM, CME

Pumped liquids	Notes	Additional information	Cast iron (EN-GJL-200)	Stainless steel (EN 1.4301/AISI 304)	Stainless steel (EN 1.4401/AISI 316)
Mineral oils					
Crude oil	b, c, e	< 20 °C	AQQV	AQQV	AQQV
Mineral lubricating oil	c, e		AVBV/AQQV	AVBV/AQQV	AVBV/AQQV
Mineral motor oil	c, e		AVBV/AQQV	AVBV/AQQV	AVBV/AQQV
Synthetic oils					
Synthetic lubricating oil	c, e		AVBV/AQQV	AVBV/AQQV	AVBV/AQQV
Synthetic motor oil	c, e		AVBV/AQQV	AVBV/AQQV	AVBV/AQQV
Silicone oil	c		AVBV/AQQV	AVBV/AQQV	AVBV/AQQV
Vegetable oils					
Corn oil	b, c		AVBV/AQQV	AVBV/AQQV	AVBV/AQQV
Olive oil	b, c		AVBV/AQQV	AVBV/AQQV	AVBV/AQQV
Peanut oil	b, c		AVBV/AQQV	AVBV/AQQV	AVBV/AQQV
Rapeseed oil	b, c		AVBV/AQQV	AVBV/AQQV	AVBV/AQQV
Soy oil	b, c		AVBV/AQQV	AVBV/AQQV	AVBV/AQQV
Cleaning					
Alkaline degreasing agent	b, g		AQQE	AQQE	AQQE
Soap (salts of fatty acids)	b	< 80 °C	AQQV	AQQV	AQQV
Organic solvents					
Acetone	e	40 °C	AVBE/AQQE	AVBE/AQQE	AVBE/AQQE
Ethyl alcohol (ethanol)	e	40 °C	AVBE/AQQE	AVBE/AQQE	AVBE/AQQE
Isopropyl alcohol	e	40 °C	AVBE/AQQE	AVBE/AQQE	AVBE/AQQE
Methyl alcohol (methanol)	e	40 °C	AVBE/AQQE	AVBE/AQQE	AVBE/AQQE
Oxidants					
Hydrogen peroxide	c	20 °C, 25 %	AQQE	AQQE	AQQE
Salts					
Ammonium bicarbonate	b, c	20 °C, 15 % 60 °C, 30 %	AQQE	AQQE	AQQE
Copper sulphate	b, c, f	60 °C, 30 %		AQQE/AQQV	AQQE/AQQV
Ferric sulphate	b, c, f	20 °C, 30 %		AQQE/AQQV	AQQE/AQQV
Potassium bicarbonate	b, c	20 °C, 20 % 60 °C, 30 %	AQQE/AQQV	AQQE/AQQV	AQQE/AQQV
Sodium carbonate	b, c, f	20 °C, 20 % 60 °C, 30 %	AQQE	AQQE	AQQE
Potassium permanganate	b, c	60 °C, 10 %		AQQE	AQQE
Sodium nitrate	b, c	20 °C, 5 % 60 °C, 30 %	AQQE/AQQV	AQQE/AQQV	AQQE/AQQV
Sodium nitrite	b, c	20 °C, 20 % 60 °C, 30 %	AQQE/AQQV	AQQE/AQQV	AQQE/AQQV
Sodium phosphate (mono)	b, c, f	60 °C, 20 %		AQQE/AQQV	AQQE/AQQV
Sodium phosphate (di)	b, c, f	30 °C, 30 % 60 °C, 30 %	AQQE/AQQV	AQQE/AQQV	AQQE/AQQV
Sodium phosphate (tri)	b, c, f	20 °C, 10 % 70 °C, 20 %	AQQE/AQQV	AQQE/AQQV	AQQE/AQQV
Sodium sulphate	b, c, f	60 °C, 30 %		AQQE/AQQV	AQQE/AQQV
Sodium sulphite	b, c, f	20 °C, 1 % 60 °C, 20 %	AQQE/AQQV	AQQE/AQQV	AQQE/AQQV
Acids					
Acetic acid		20 °C, 15 % 60 °C, 50 %		AQQE	AQQE
Citric acid	c, f	40 °C, 50 %		AQQE	AQQE
Formic acid	c	20 °C, 30 % 40 °C, 30 %		AQQE	AQQE
Nitric acid	c	25 °C, 40 % 40 °C, 40 %		AQQE	AQQE
Oxalic acid	f	20 °C, 10 % 50 °C, 10 %		AQQE	AQQE
Phosphoric acid	b, c, f	70 °C, 40 %		AQQE/AQQV	AQQE/AQQV

Pumped liquids	Notes	Additional information	Cast iron (EN-GJL-200)	Stainless steel (EN 1.4301/AISI 304)	Stainless steel (EN 1.4401/AISI 316)
Sulphuric acid	b	20 °C, 1 %		AQQE/AQQV	
		20 °C, 5 %			AQQE/AQQV
Sulphurous acid		20 °C, 10 %		AQQE	AQQE
		50 °C, 10 %		AQQK	AQQK
Alkalies					
Ammonium hydroxide		30 °C, 30 %	AQQE	AQQE	AQQE
Calcium hydroxide	b	30 °C, 5 %	AQQE	AQQE	AQQE
Potassium hydroxide	c, f	20 °C, 20 %	AQQE		
		60 °C, 20 %		AQQE	AQQE
Sodium hydroxide	c, f	20 °C, 20 %	AQQE		
		80 °C, 20 %		AQQE	AQQE

Pump

The CM and CME pumps are non-self-priming, horizontal, multistage centrifugal pumps. The pumps have axial suction port and radial discharge port and are mounted on a base plate.

All movable parts are made of stainless steel.

The pumps are available with mains-operated motors (CM pumps) and electronically speed-controlled motors (CME pumps).

All pumps incorporate a maintenance-free mechanical O-ring shaft seal with fixed driver.

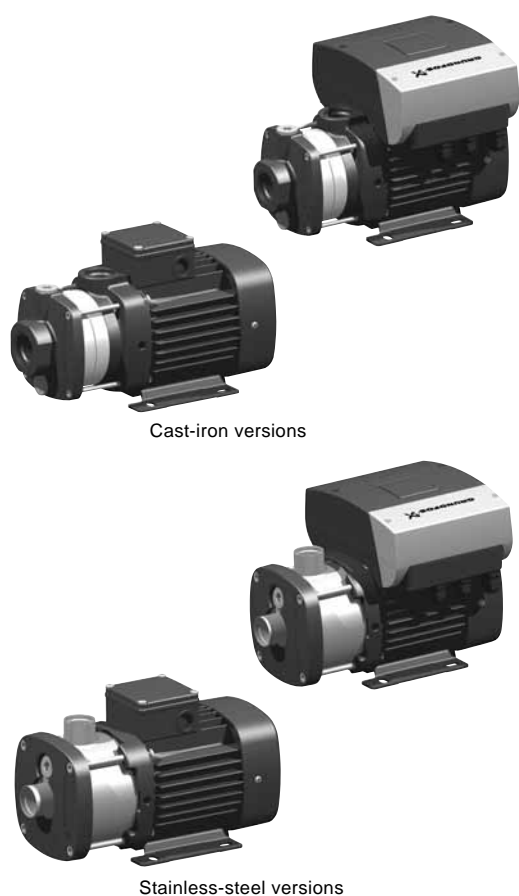

Fig. 11 CM and CME pumps

Motor

CM and CME pumps are fitted with totally enclosed, fan-cooled, 2-pole motors with principal dimensions to EN standards.

Electrical tolerances comply with EN 60034.

CM and CME pumps up to and including 1.1 kW are fitted with single-phase motors as standard. CM and CME pumps from 1.1 to 7.5 kW are available with three-phase motors.

Electrical data

Insulation class	F
Enclosure class	IP55*
Supply voltages (tolerance $\pm 10\%$)	CM 1 x 220 V, 60 Hz 1 x 115/230 V, 60 Hz 1 x 220-240 V, 50 Hz 1 x 127 V, 60 Hz 3 x 208-230/440-480 V, 60 Hz 3 x 220-240/380-415 V, 50 Hz 3 x 200/346 V, 50 Hz; 200-220/346-380 V, 60 Hz 3 x 575 V, 60 Hz 3 x 400 V, 50/60 Hz 3 x 380-415 V, 50 Hz; 440-480 V, 60 Hz 3 x 220-240/380-415 V, 50 Hz 3 x 220-255/380-440 V, 60 Hz CME 1 x 220-240 V, 50/60 Hz 3 x 380-480 V, 50/60 Hz 1 x 208-230 V, 50/60 Hz 3 x 460-480 V, 60 Hz

* IP55 is not recommended for operation in condensing environments. For such environments, IP54 is recommended and available on request.

Motor protection

Mains-operated motors (CM)

Single-phase Grundfos motors have a built-in thermal overload switch (IEC 34-11: TP 211).

Note: Single-phase motors with UL approval (1 x 115/230 V, 60 Hz) have no built-in motor protection and therefore require external motor protection.

Three-phase motors **must** be connected to a motor starter in accordance with local regulations.

Three-phase Grundfos motors from 3 kW and upwards have a built-in thermistor (PTC) according to DIN 44082 (IEC 34-11: TP 211).

Electronically speed-controlled motors (CME)

CME pumps require no external motor protection. The MGE motor incorporates thermal protection against slow overloading and blocking (IEC 34-11: TP 211).

Terminal box positions

As standard the terminal box is mounted in 12 o'clock position as shown in fig. 12. The pump is available with other terminal box positions on special request. See fig. 12.

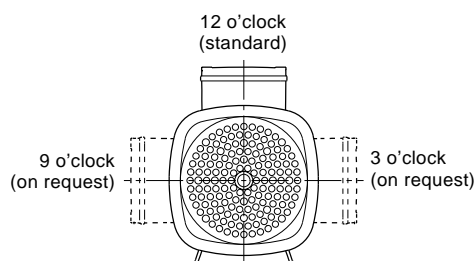

Fig. 12 Terminal box positions

Shaft seal

The shaft seal for the CM and CME pumps is of the O-ring type, which makes it very flexible when different types of O-rings and seal-face materials are needed. The shaft seal has a fixed seal driver which ensures a reliable rotation of all parts – even under the most extreme operating conditions.

Due to the special design of the shaft seal and the interfaces to the rest of the pump construction, the dry-running capabilities are improved significantly compared to most other similar shaft seals and pump types. Furthermore, improvements have been made to reduce the risk and effect of sticking. The shaft seal types available can be found in *Selection of shaft seal* on page 33 where the key parameters of selecting a shaft seal are also described.



TM04 3833 0409

Fig. 13 Exploded view of shaft seal

Note: The available shaft seals for CM and CME pumps are very robust and durable, but dry running must always be avoided.

Details regarding operating conditions for the shaft seal can be found in *Operating range of the shaft seal* on page 16.

Further information about the shaft seal can be found in the separate data booklet covering shaft seals which can be downloaded from WebCAPS. See *Further product documentation* on page 116.

Title	Publication number
Shaft seals	96519875

Pipe connections

A wide range of pipe connections are available for the CM and CME pumps:

- Tri-Clamp®
- DIN flange
- ANSI flange
- JIS flange
- PJE coupling
- Whitworth thread Rp
- internal NPT thread.

Some of the available pipe connections are shown in fig. 14.

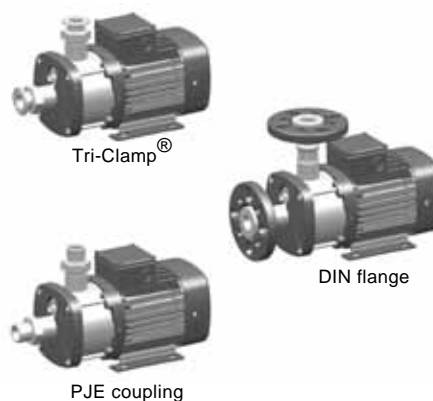

TM04 3837 0409

Fig. 14 Examples of pipe connections

Alternative connection positions

The pump is available with various connection positions on special request. See fig. 15.

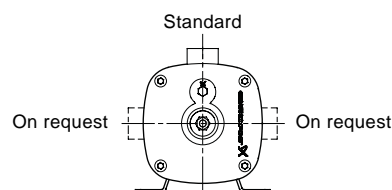

TM03 8709 1008

Fig. 15 Alternative connection positions

CM(E) 1-A

(A = cast iron, EN-GJL-200)

Sectional drawing

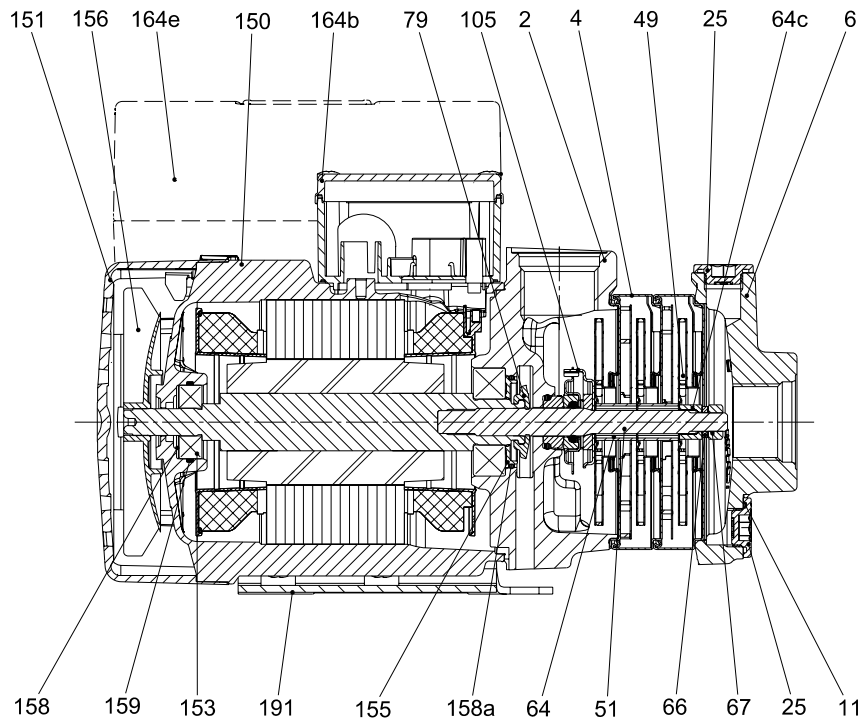

TMD04 3723 0309

Fig. 16 CM(E) 1-3 with MG(E) 71 motor

Components

Pos.	Component	Pos.	Component	Pos.	Component
2	Discharge part	64c	Clamp	155	Bearing cover plate
4	Chamber	66	Washer (NORD-LOCK®)	156	Fan
6	Inlet part	67	Nut	158	Corrugated spring
11	O-ring	79	Diverting disc	158a	O-ring
25	Plug	105	Shaft seal	159	O-ring
49	Impeller	150	Stator housing	164b, 164e	Terminal box
51	Pump shaft	151	Fan cover	191	Base plate
64	Spacing pipe	153	Ball bearing		

CM(E) 1-I and CM(E) 1-G

(I = EN 1.4301/AISI 304 and G = EN 1.4401/AISI 316)

Sectional drawing

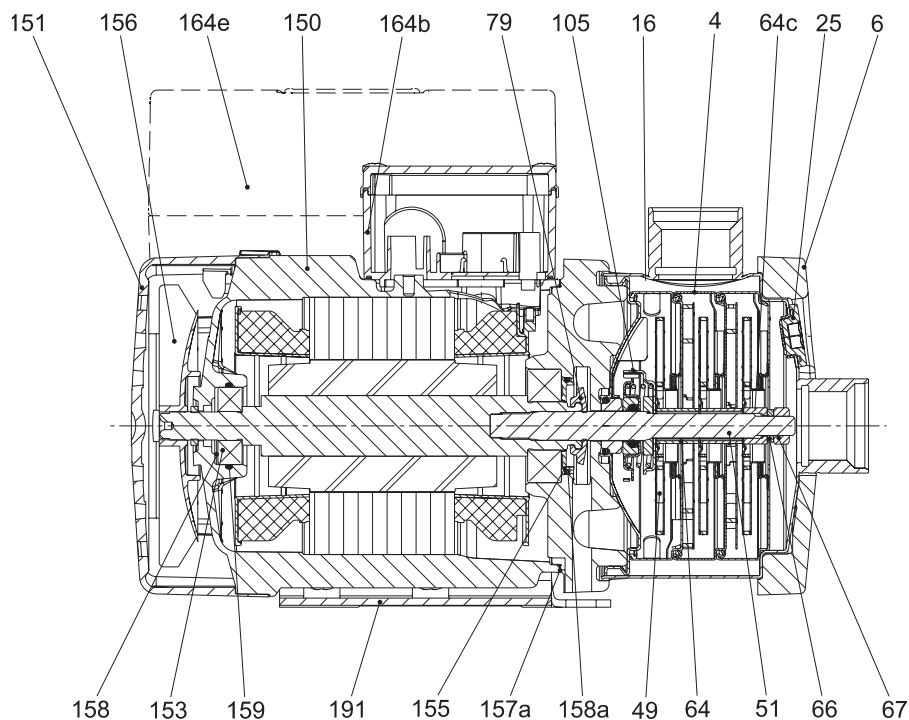

TM04 3722 0309

Fig. 17 CM(E) 1-3 with MG(E) 71 motor

Components

Pos.	Component	Pos.	Component	Pos.	Component
4	Chamber	66	Washer (NORD-LOCK®)	156	Fan
6	Flange	67	Nut	157a	Gasket
16	Sleeve	79	Diverting disc	158	Corrugated spring
25	Plug	105	Shaft seal	158a	O-ring
49	Impeller	150	Stator housing	159	O-ring
51	Pump shaft	151	Fan cover	164b, 164e	Terminal box
64	Spacing pipe	153	Ball bearing	191	Base plate
64c	Clamp	155	Bearing cover plate		

Material specification

Pos.	Description	Material	Pump material version					
			Cast iron (EN-GJL-200)		Stainless steel (EN 1.4301/AISI 304)		Stainless steel (EN 1.4401/AISI 316)	
			DIN W.-Nr.	ISO/AISI/ ASTM	DIN W.-Nr.	ISO/AISI/ ASTM	DIN W.-Nr.	ISO/AISI/ ASTM
Motor parts								
156b	Motor flange	Cast iron						
150	Stator housing	Silumin (Alu)						
151	Fan cover	Composite PBT/PC						
153	Ball bearing							
156	Fan	Composite PA 66 30 % GF						
158	Corrugated spring	Steel						
164b	Terminal box, MG	Composite PC/ASA or silumin (Alu)						
164e	Terminal box, MGE							
191	Base plate	Painted steel	1.0330.3		1.0330.3		1.0330.3	
79	Diverting disc	Silicone fluid (LSR)						
155	Bearing cover plate	PPS						
Pump parts								
105	Shaft seal, steel parts	Stainless steel	1.4301/ 1.4401	AISI 304/ AISI 316	1.4301/ 1.4401	AISI 304/ AISI 316	1.4401	AISI 316
	Shaft seal, seal faces	Al ₂ O ₃ /carbon or SiC						
51	Pump shaft	Stainless steel	1.4057	AISI 431	1.4301/ 1.4401	AISI 304/ AISI 316	1.4401	AISI 316
11 158a 159	O-rings	EPDM, FKM or FFKM						
157a	Gasket ¹⁾	Aramide fibres (nbr)						
2	Discharge part ²⁾	Cast iron						
6	Inlet part ²⁾	Cast iron						
4	Chamber	Stainless steel	1.4301/ 1.4401	AISI 304/ AISI 316	1.4301/ 1.4401	AISI 304/ AISI 316	1.4401	AISI 316
25	Plug	Stainless steel	1.4401	AISI 316L	1.4401	AISI 316L	1.4401	AISI 316L
49	Impeller	Stainless steel	1.4301/ 1.4401	AISI 304/ AISI 316	1.4301/ 1.4401	AISI 304/ AISI 316	1.4401	AISI 316
64	Spacing pipe	Stainless steel	1.4401	AISI 316	1.4401	AISI 316	1.4401	AISI 316
64c	Clamp	Stainless steel	STX2000 ³⁾		STX2000 ³⁾		STX2000 ³⁾	
6	Flange ¹⁾	Cast iron						
16	Sleeve	Stainless steel			1.4301/ 1.4401	AISI 304/ AISI 316	1.4401	AISI 316
67	Nut	Stainless steel A4						
66	Washer (NORD-LOCK®)	Steel	1.4547		1.4547		1.4547	

¹⁾ Only in CM(E)-I/G pumps.

²⁾ Only in CM(E)-A pumps.

³⁾ STX2000 ~ CrNiMO 22 19 4.

Communication with CME pumps

Communication with CME pumps is possible by means of

- a central building management system
- a remote control (Grundfos R100)
- a control panel.

Central building management system

The operator can communicate with a CME pump at a distance. Communication can take place via a central building management system allowing the operator to monitor and change control modes and setpoint settings.

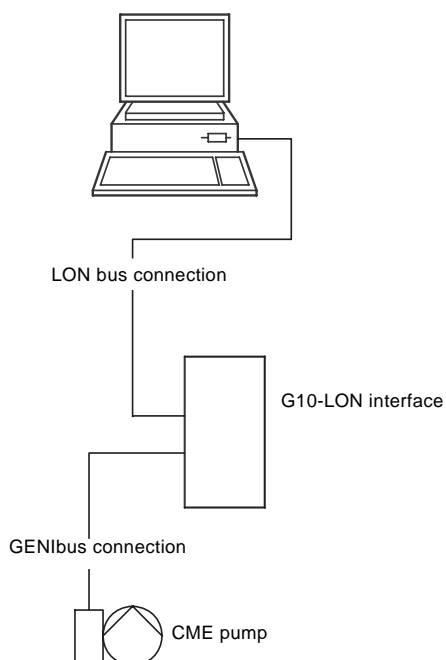

Fig. 18 Structure of a central building management system

TM02 6592 1103

Remote control

The Grundfos R100 remote control is available as an accessory. See page 112.

The operator can communicate with the CME pump by pointing the IR-signal transmitter at the control panel of the terminal box.

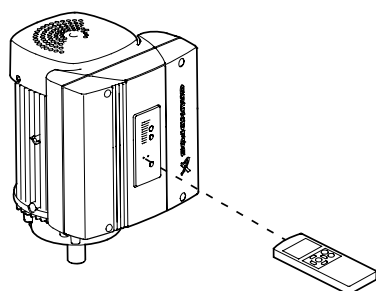

Fig. 19 R100 remote control

TM03 0141 4104

The operator can monitor and change control modes and settings of the CME pump with the R100.

Control panel

The operator can change the setpoint settings manually on the control panel of the CME pump terminal box.



Fig. 20 Control panel of a CME pump

TM00 7600 0404

Speed control of CME pumps

Affinity equations

Normally, CME pumps are used in applications characterised by a **variable** flow. Consequently, it is not possible to select a pump that is constantly operating at its optimum efficiency.

In order to achieve optimum operating economy, the duty point should be close to the optimum efficiency (η) for most operating hours.

Between the min. and max. performance curves, CME pumps have an infinite number of performance curves, each representing a specific speed. It may therefore not be possible to select a duty point close to the max. curve.

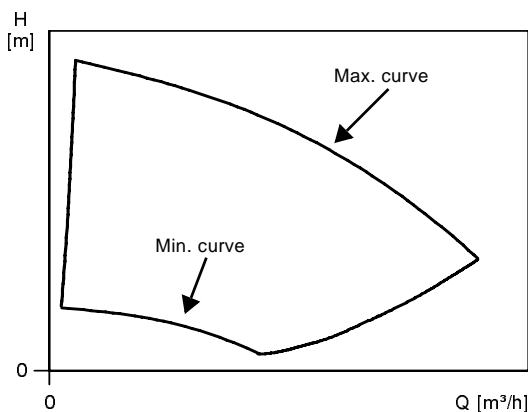

Fig. 21 Min. and max. performance curves

In situations where it is not possible to select a duty point close to the max. curve, use the affinity equations below. The head (H), the flow rate (Q) and the input power (P) are the appropriate variables for calculating the motor speed (n).

Note: The approximated formulas apply on condition that the system characteristic remains unchanged for n_n and n_x and that it is based on the formula $H = k \times Q^2$ where k is a constant.

The power equation implies that the pump efficiency is unchanged at the two speeds. In practice, this is **not** quite correct.

Finally, it is worth noting that the efficiency of the frequency converter and the motor **must** be taken into account if a precise calculation of the power saving resulting from a reduction of the pump speed is wanted.

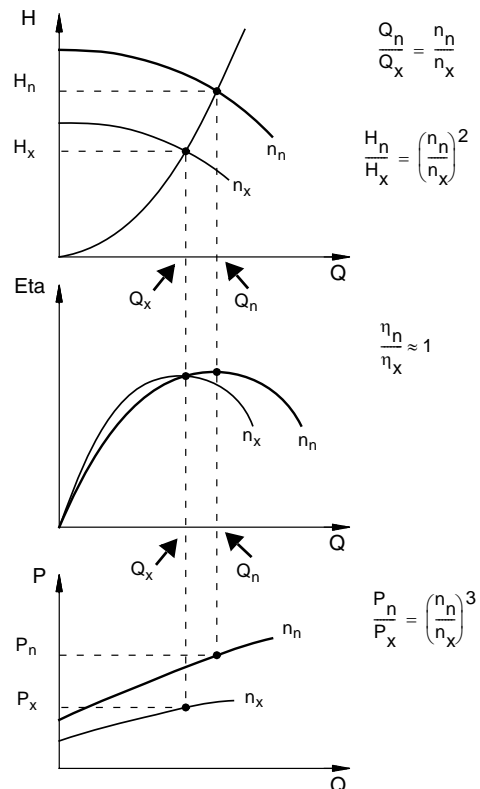

Fig. 22 Affinity equations

Legend

- H_n Rated head in metres
- H_x Current head in metres
- Q_n Rated flow rate in m^3/h
- Q_x Current flow rate in m^3/h
- n_n Rated motor speed in min^{-1}
- n_x Current motor speed in min^{-1}
- η_n Rated efficiency in %
- η_x Current efficiency in %

WinCAPS and WebCAPS

WinCAPS and WebCAPS are selection programs offered by Grundfos.

The two programs make it possible to calculate the specific duty point and energy consumption of a CME pump.

When you enter the dimensions of the pump, WinCAPS and WebCAPS can calculate the exact duty point and energy consumption. For further information, see page 116.

TM01 4916 4803

TM00 8720 3496

CM pumps connected to Grundfos CUE, external frequency converters



GrA 4404

Fig. 23 Grundfos CUE product range

Grundfos CUE is a complete range of frequency converters for pump control in a wide range of applications. Grundfos CUE is designed for wall mounting.

Grundfos CUE provides a variety of benefits to the end-user.

The benefits include

- Grundfos CME pump functionality and user interface
- application- and pump family-related functions
- increased comfort compared to mains-operated pump solutions
- simple installation and commissioning compared to standard frequency converters.

Functions

Intuitive start-up guide

The start-up guide enables easy installation and commissioning as well as plug-and-pump convenience. Few settings need to be made by the installer as the rest is done automatically or preset from the factory.

Smart user interface



TM04 3283 4108

Fig. 24 Grundfos CUE control panel

Grundfos CUE features a unique user-friendly control panel with graphic display and easy-to-use buttons. Panel layout resembles the well-known Grundfos R100 remote control, which is used with Grundfos CME pumps.

Controlling the value you choose

Grundfos CUE has a built-in PI controller offering closed-loop control of a desired value.

The values include

- constant differential-pressure
- proportional pressure
- constant temperature
- constant flow.

Wide product range

The CUE product range is quite comprehensive, covering five different voltage ranges, enclosure classes IP20/21 (Nema 1) and IP54/55 (Nema 12), and a wide range of output powers.

The table below provides a general overview.

Input voltage [V]	Output voltage [V]	Motor [kW]
1 x 200-240	3 x 200-240	1.1 - 7.5
3 x 200-240	3 x 200-240	0.75 - 45
3 x 380-500	3 x 380-500	0.55 - 250
3 x 525-600	3 x 525-600	0.75 - 7.5

CM and CME pumps with certificates

Grundfos can provide the certificates listed below for CM and CME pumps:

Certificates

Certificate	Description
Certificate of compliance with the order	According to EN 10204, 2.1. Grundfos document certifying that the pump supplied is in compliance with the order specifications.
Test certificate. Non-specific inspection and testing.	According to EN 10204, 2.2. Certificate with inspection and test results of a non-specific pump.
Inspection certificate 3.1	Grundfos document certifying that the pump supplied is in compliance with the order specifications. Inspection and test results are mentioned in the certificate.
Inspection certificate	<p>Grundfos document certifying that the pump supplied is in compliance with the order specifications. Inspection and test results are mentioned in the certificate. Certificate from the surveyor is included.</p> <p>We offer the following inspection certificates:</p> <ul style="list-style-type: none"> • Lloyds Register of Shipping (LRS) • Det Norske Veritas (DNV) • Germanischer Lloyd (GL) • Bureau Veritas (BV) • American Bureau of Shipping (ABS) • Registro Italiano Navale Agenture (RINA) • China Classification Society (CCS) • Russian maritime register of Shipping (RS) • Biro Klassifikasio Indonesia (BKI) • United States Coast Guard (USCG) • Nippon Kaiji Koykai (NKK)
Standard test report	Grundfos document certifying that the materials used for the main components of the specific pump are manufactured by Grundfos, tested, inspected, and conform to the full requirements of the appropriate catalogues, drawings and specifications.

Examples of the certificates are shown on page 30.

Examples of certificates

Certificate of compliance with the order

BE > THINK > INNOVATE >		GRUNDFOS >	
Certificate of compliance with the order			
EN 10204 2.1			
Customer information			
Customer name			
Customer order no.			
Customer Tag no.			
GRUNDFOS order no.			
Product type			
<p>We the undersigned hereby guarantee and certify that the materials and/or parts for the above mentioned product were manufactured, tested, inspected, and conform to the full requirements of the appropriate catalogues, drawings and/or specifications relative thereto.</p>			
GRUNDFOS Date: _____ Signature: _____ Name: _____ Dept.: _____			
Part no. 96.50.78.95/1001002			

TM03 4165 1706

Test certificate

BE > THINK > INNOVATE >		GRUNDFOS >	
Test certificate			
Non-specific inspection and testing			
EN 10204 2.2			
Customer information			
Customer name			
Customer order no.			
Customer TAG no.			
GRUNDFOS order no.			
Pump			
Pump type		Part number	
Motor make		Part number	
Flow	m ³ /h		
Head	m		
Power P2	kW		
Voltage	V		
Frequency	Hz		
Full load current	A		
Motor speed	min ⁻¹		
<p>We the undersigned hereby guarantee and certify that the materials and/or parts for the above mentioned product were manufactured, tested, inspected, and conform to the full requirements of the appropriate catalogues, drawings and / or specifications relative thereto.</p>			
GRUNDFOS Date: _____ Signature: _____ Name: _____ Dept.: _____			
Part no. 96.50.78.96/1001002			

TM03 4163 1706

Inspection certificate 3.1

BE > THINK > INNOVATE >		GRUNDFOS >	
Inspection certificate.			
EN 10204 3.1			
Manufactured by			
GRUNDFOS order no.			
GRUNDFOS DUT id.			
Customer order no.			
Customer name and address			
Shipyards / factory			
Ship / new building			
Customer TAG no.			
Classifying society	GRUNDFOS authorized department		
Pump		Motor	
Pump type		Make	
Part number		Part number	
Serial no.		Serial No.	
Flow rate (m ³ /h)		P2 (kW)	
Head (m)		Voltage (V)	
Max. ope. P/t (bar / °C)		Current (A)	
Base/Pump head cover	Din / W. - No.	n (min ⁻¹)	
Impeller/guide vanes		Frequency (Hz)	
Shaft/sleeve		Insulation class	
		Power factor	
Customer's requirements			
Flow rate (m ³ /h)		Head (m)	
Test result ref. requirements			
Q (m ³ /h)	H (m)	n (min ⁻¹)	I (A) P1 (kW)
Hydrostatic test: Bar – no leaks or deformation observed			
GRUNDFOS Date: _____ Signature: _____ Name: _____ Dept.: _____			
Part no. 96.50.78.97/1014142			

TM03 4162 3607

Standard pump test report

BE > THINK > INNOVATE >		GRUNDFOS >	
Standard test report			
Customer information			
Customer name			
Customer order no.			
Customer Tag no.			
GRUNDFOS order no.			
Product type			
GRUNDFOS DUT id.			
Part number			
<p>We the undersigned hereby guarantee and certify that the materials and/or parts for the above mentioned product were manufactured by GRUNDFOS, tested, inspected, and conform to the full requirements of the appropriate catalogues, drawings and/or specifications relative thereto.</p> <p>The attached test result is from the above mentioned pump.</p>			
GRUNDFOS Date: _____ Signature: _____ Name: _____ Dept.: _____			
Part no. 96.50.79.30/P01 /A/22775			

TM03 4143 1706

Selection of pumps

Selection of pumps should be based on these elements:

- the duty point of the pump (see below)
- dimensional data such as pressure loss as a result of height differences, friction loss in the pipework, pump efficiency, etc. (see below)
- pump materials (see page 32)
- pump connections (see page 32)
- shaft seal (see page 33).

Duty point of the pump

From a duty point it is possible to select a pump on the basis of the curve charts starting on page 35.

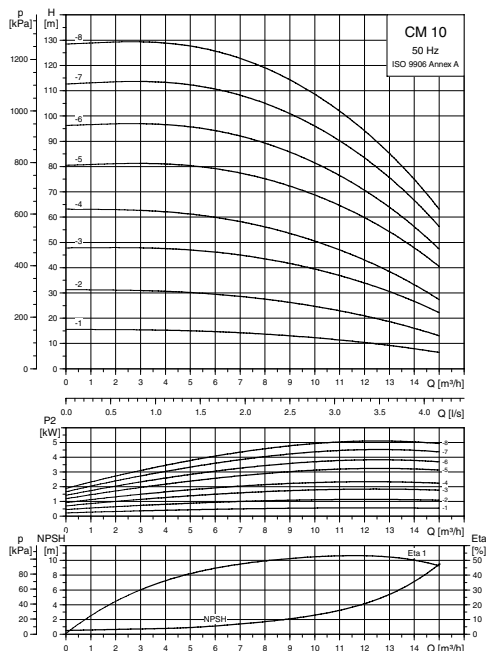

Fig. 25 Example of a curve chart

TM04 3338 4308

Dimensional data

When sizing a pump, take the following factors into account:

- Required flow and pressure at the draw-off point.
- Pressure loss as a result of height differences (H_{geo}).
- Friction loss in the pipework (H_f). It may be necessary to account for pressure loss in connection with long pipes, bends or valves, etc.
- Best efficiency at the estimated duty point.*
- NPSH value.

For calculation of the NPSH value, see *Minimum inlet pressure, NPSH* on page 17.

* See *Selection of CME pumps* on page 33 for further information about sizing CME pumps.

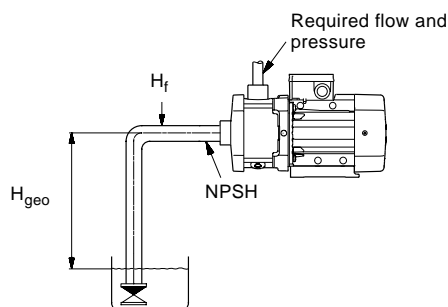

Fig. 26 Dimensional data

TM04 3486 4508

Pump efficiency

When sizing the pump, the efficiency (η) should be considered so that the pump will operate at or near its maximum efficiency, for instance on the right-hand side in the curve example in fig. 27.

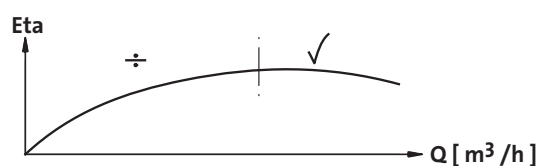

Fig. 27 Best efficiency

TM00 9190 1303

Before determining the best efficiency point, the operation pattern of the pump needs to be identified. If the pump is expected to operate at the same duty point, then select a CM pump which is operating at a duty point corresponding with the best efficiency of the pump. The example in fig. 28 shows how to check the pump efficiency when selecting a CM pump.

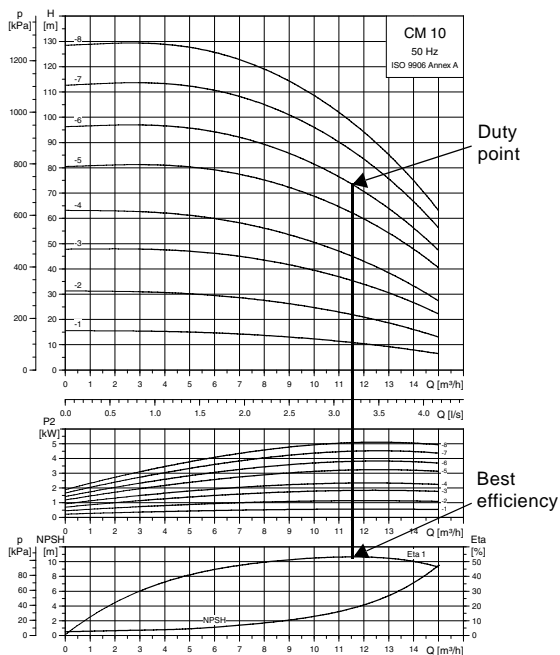

Fig. 28 Example of a CM pump's duty point

Pump materials

Select the material variant on the basis of the liquid to be pumped. The table below gives a general recommendation regarding selection of pump material.

Liquid to be pumped	Material in contact with pump media	Pump type
Clean, non-aggressive liquids such as potable water and oils	Cast iron* (EN-GJL-200)	CM(E)-A
Industrial liquids and acids	Stainless steel (EN 1.4301/AISI 304)	CM(E)-I
	Stainless steel (EN 1.4401/AISI 316)	CM(E)-G

* The impeller, chamber and filling plugs are made of stainless steel (EN 1.4301/AISI 304).
The pump shaft is made of stainless steel (EN 1.4057/AISI 431).

For more specific selection based on the pumped liquid, see *List of pumped liquids* on page 18, or contact Grundfos.

Pump connections

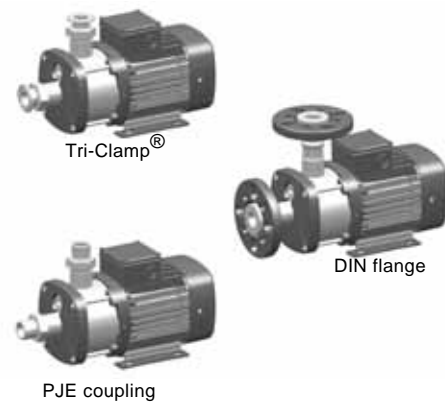

Fig. 29 Examples of pump connections

Selection of pump connection depends on the rated pressure and pipework. To meet any requirement, the CM and CME pumps offer a wide range of flexible connections such as:

- Tri-Clamp®
- DIN flange
- ANSI flange
- JIS flange
- PJE coupling
- Whitworth thread Rp
- internal NPT thread.

TM04 3937 0409

TM02 7302 3103

Selection of shaft seal

As standard, the CM and CME pumps are fitted with a Grundfos O-ring type shaft seal with fixed driver suitable for the most common applications.



TM04 3934 0409

Fig. 30 Shaft seal (O-ring type with fixed driver)

The table below shows the available shaft seal types for CM and CME pumps.

Pump type	Shaft seal type	Material	Rubber parts
CM, CME	AQQE	Stainless steel	EPDM (E) FKM (V) FFKM
	AQQV		
	AQQK		
	AVBE		
	AVBV		

These key parameters must be taken into account when selecting the shaft seal:

- type of pumped liquid
- liquid temperature
- maximum pressure.

Use the curve in fig. 9 on page 16 to select a suitable shaft seal. If the pumped liquid differs from water, a suitable shaft seal can be found in *List of pumped liquids* on page 18.

Note: The list should be applied with some caution, as factors such as concentration of the pumped liquid, liquid temperature or pressure may affect the chemical resistance of a specific pump version.

Selection of CME pumps

CME pumps are normally used in applications characterised by a variable flow. Consequently, it is not possible to select a pump that is constantly operating at its optimum efficiency. In order to achieve optimum operating economy, the duty point should therefore be close to the optimum efficiency (η) for most operating hours. For further information see *CME pumps* on page 26.

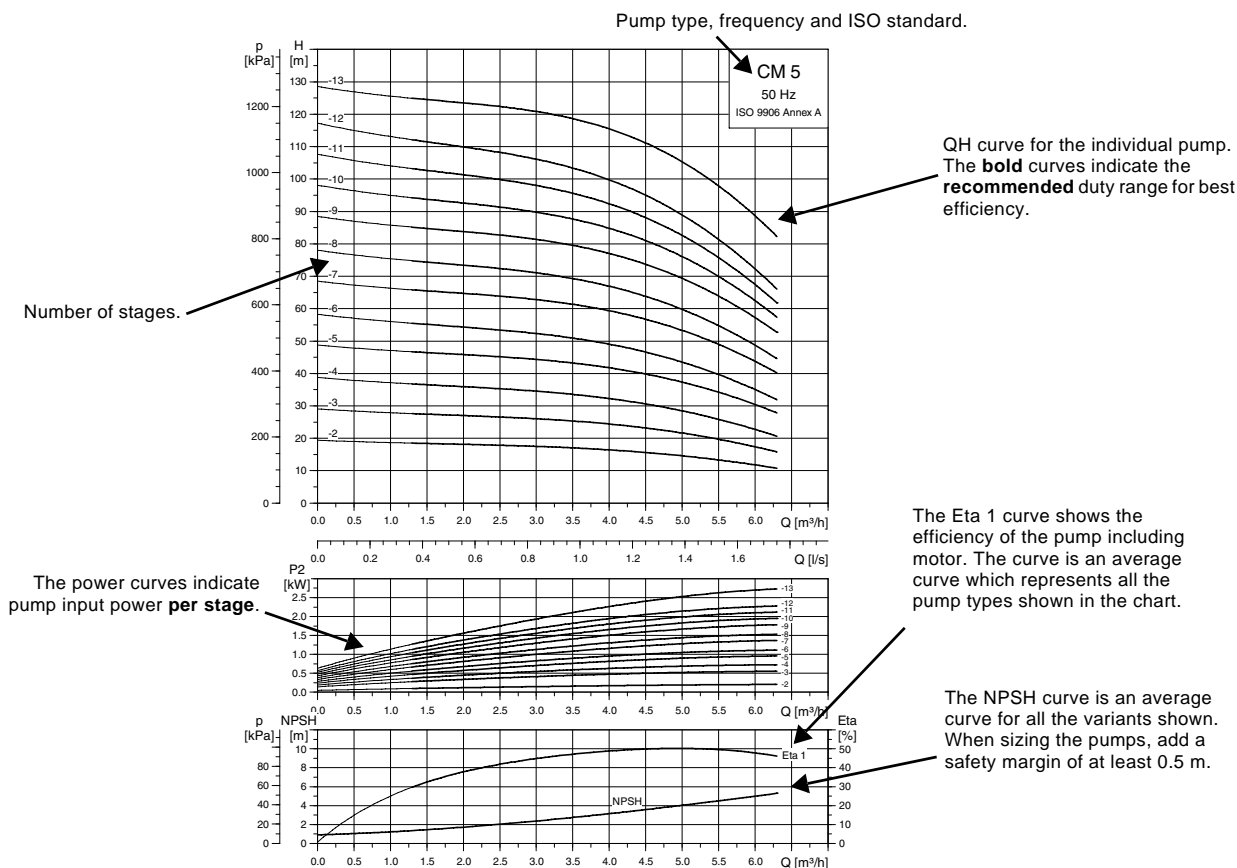

TM04-3336 4308

Fig. 31 How to read the curve charts

Guidelines to performance curves

The guidelines below apply to the curves shown on the following pages:

- Tolerances to ISO 9906, Annex A, if indicated.
- The motors used for the measurements are the specifically designed motors for CM and CME pumps. The motors are based on Grundfos standard motors (MG or MGE).
- Measurements have been made with airless water at a temperature of +20 °C.
- The curves apply to the following kinematic viscosity: $\nu = 1 \text{ mm}^2/\text{s}$ (1 cSt).
- The QH curves apply to rated motor speeds of approximately 2900 min⁻¹ (50 Hz) and approximately 3400 min⁻¹ (60 Hz). All curves are based on current motor speeds.

Note: Please refer to WebCAPS for more precise curves. In WebCAPS, it is also possible to adjust the curves depending on the density and viscosity.

- When the motor is running at the lowest or highest rated voltage, the pump performance will usually vary by $\pm 0.5 - 1.0 \text{ m}$ at a given duty point.

- The conversion between head H (m) and pressure p (kPa) applies to a water density of $\rho = 1000 \text{ kg/m}^3$.
- Due to the risk of overheating, the pumps should not be used at a flow below the minimum flow rate. The curve in fig. 32 shows the minimum flow rate as a percentage of the rated flow rate in relation to the liquid temperature.

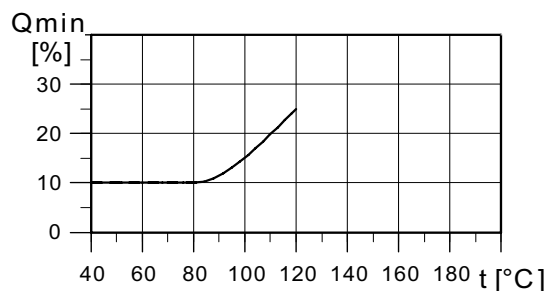

Fig. 32 Minimum flow rate

TM04-3791 5005

Performance curves, CM 50 Hz

CM 1
50 Hz

CM 1

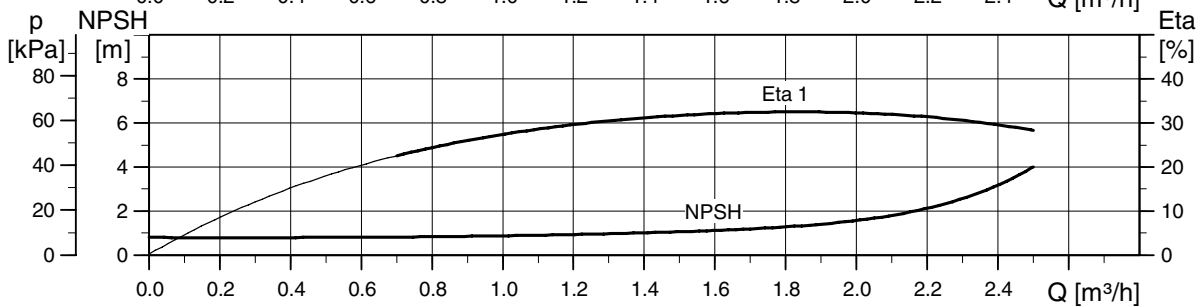
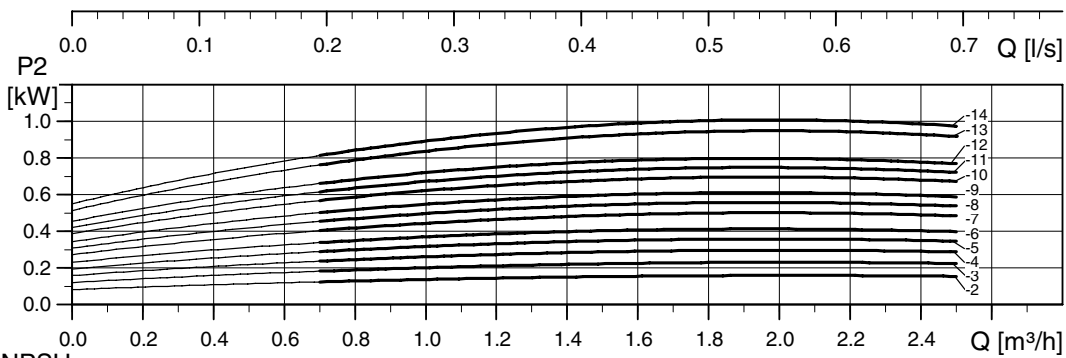
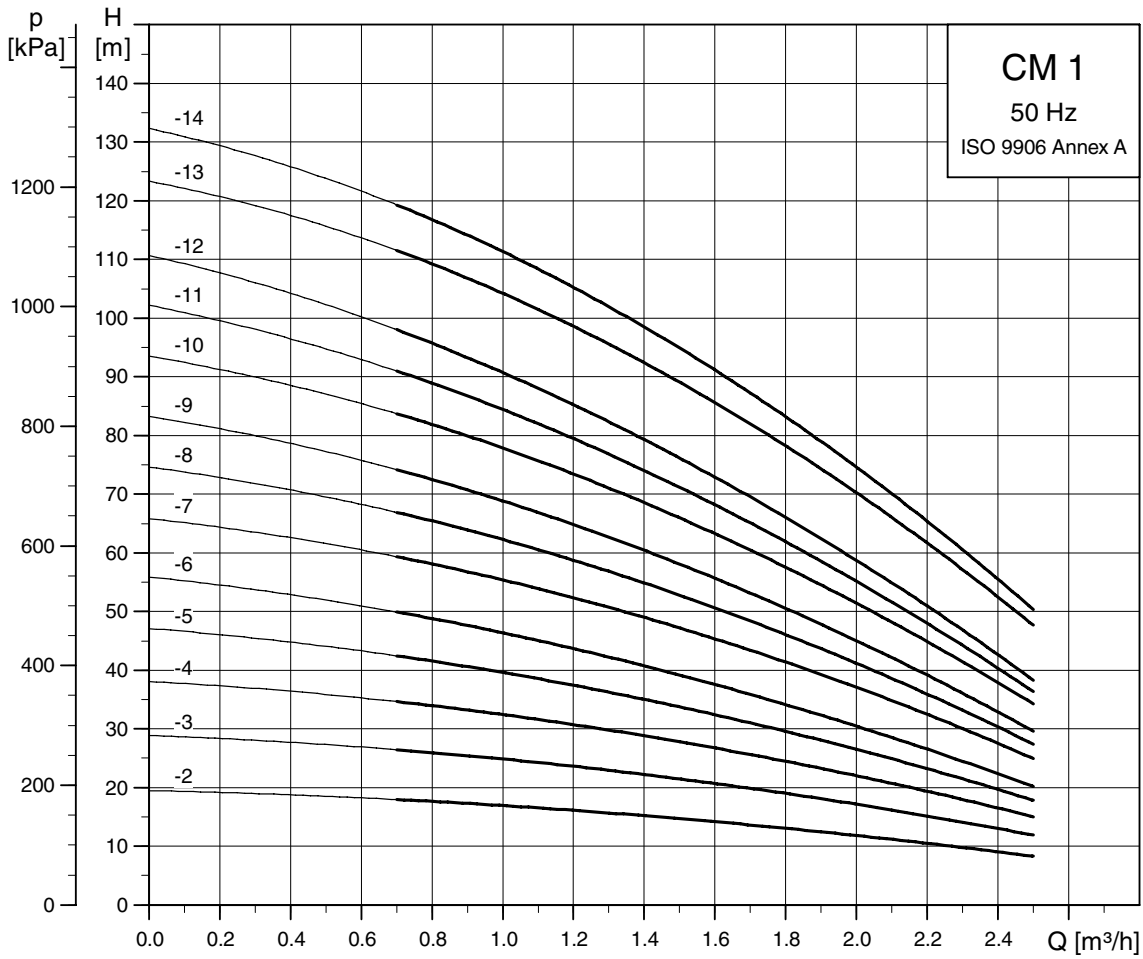

Note: The curves above are based on a 3 phase motor running with fixed speed

TM04 3334 4308

Performance curves, CM 50 Hz

CM 3
50 Hz

CM 3

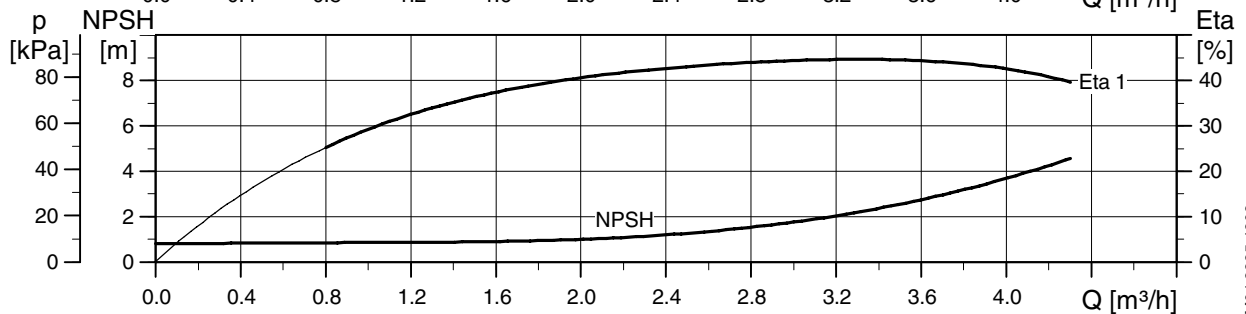
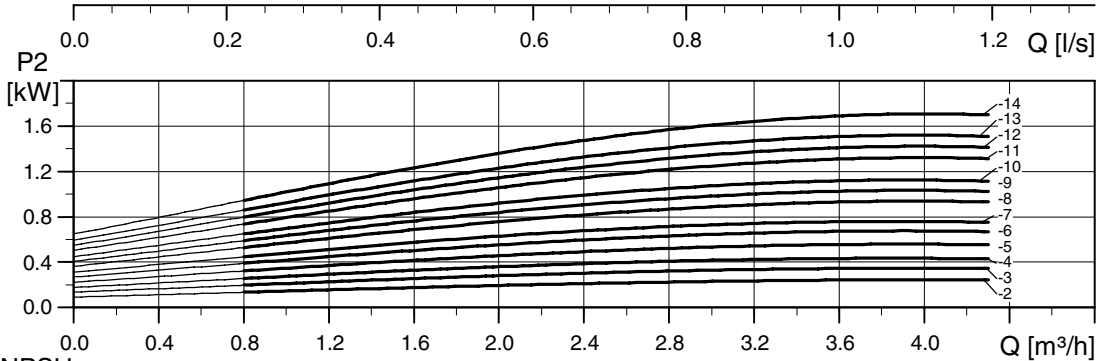
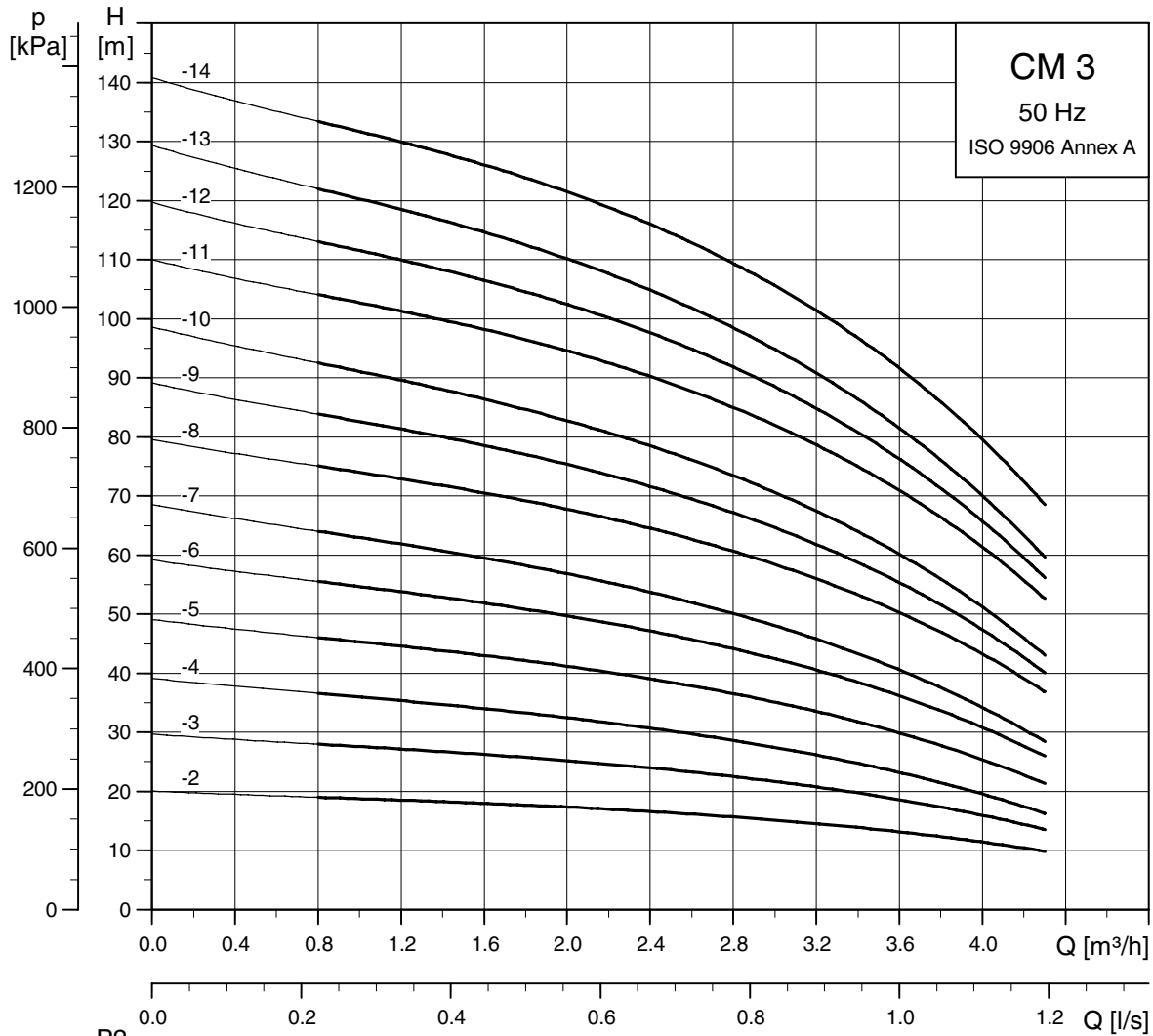

TM04 3335 4308

Performance curves, CM 50 Hz

CM 5
50 Hz

CM 5

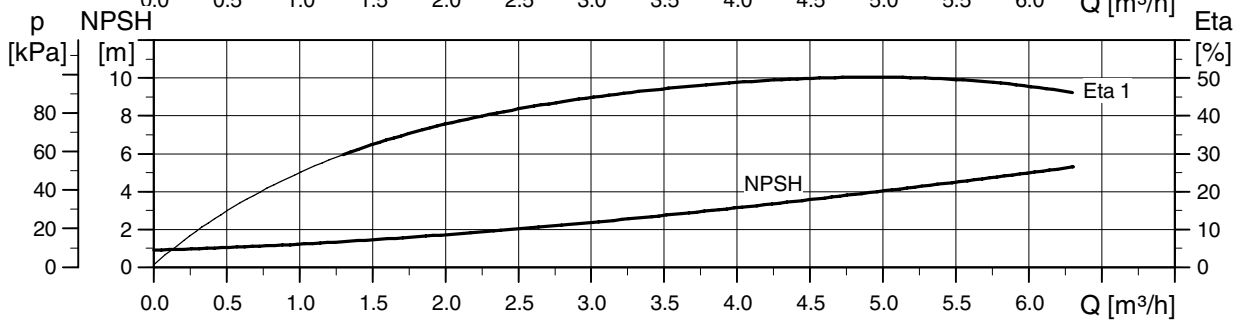
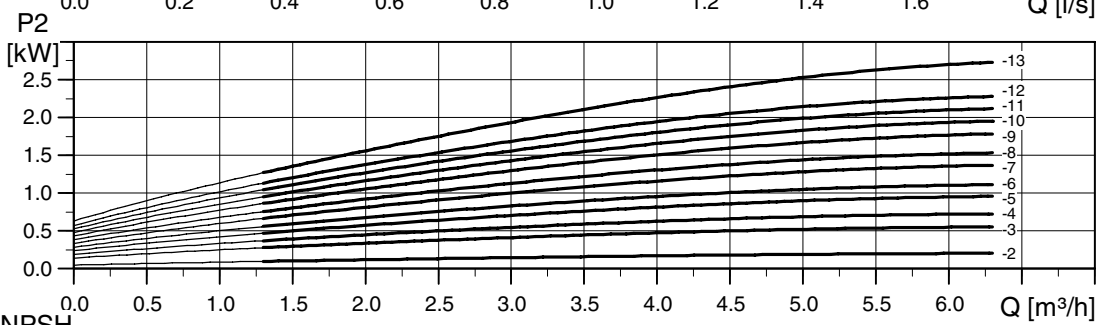
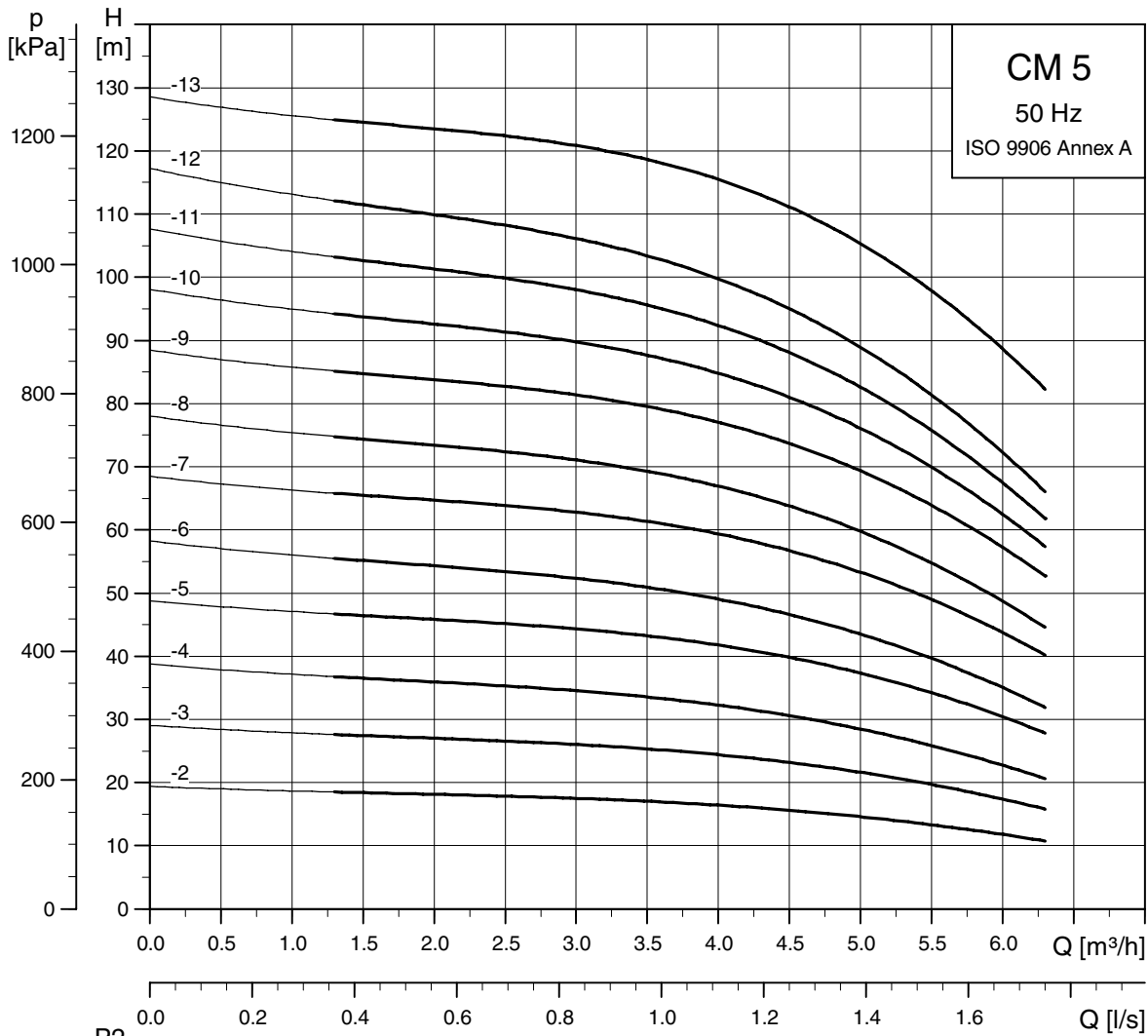

TMD4 3336 4308

Performance curves, CM 50 Hz

CM 10
50 Hz

CM 10

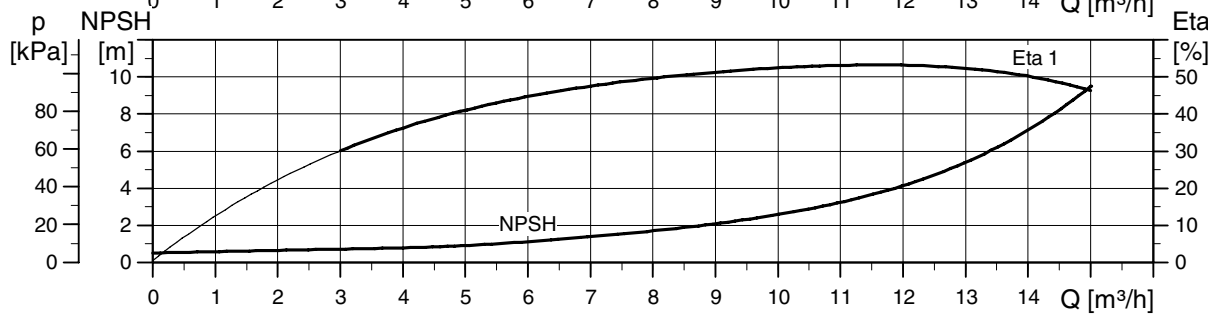
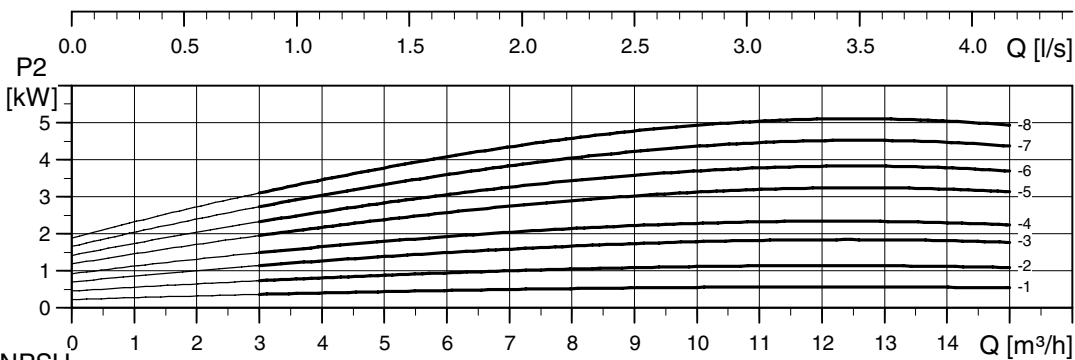
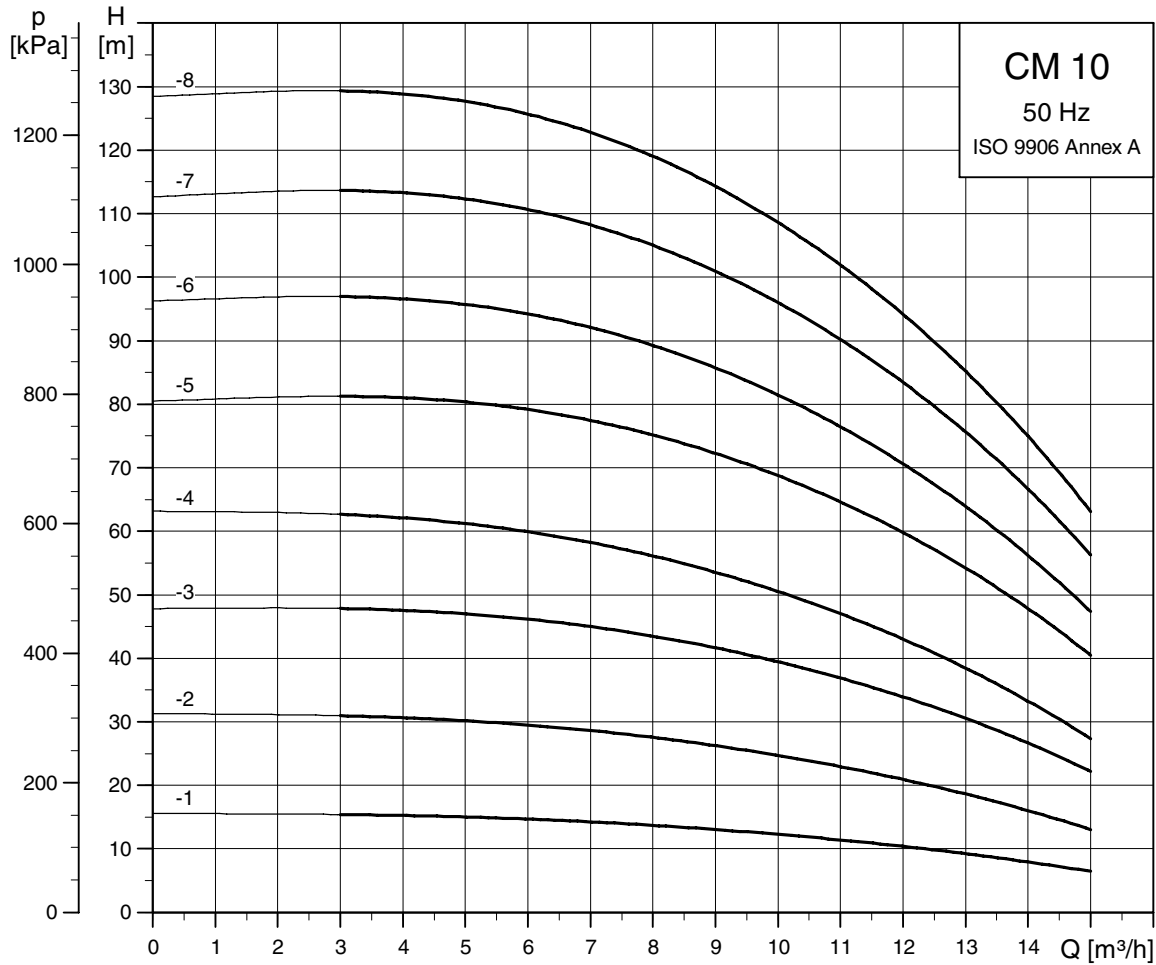

TMD4 3337 4308

Performance curves, CM 50 Hz

CM 15
50 Hz

CM 15

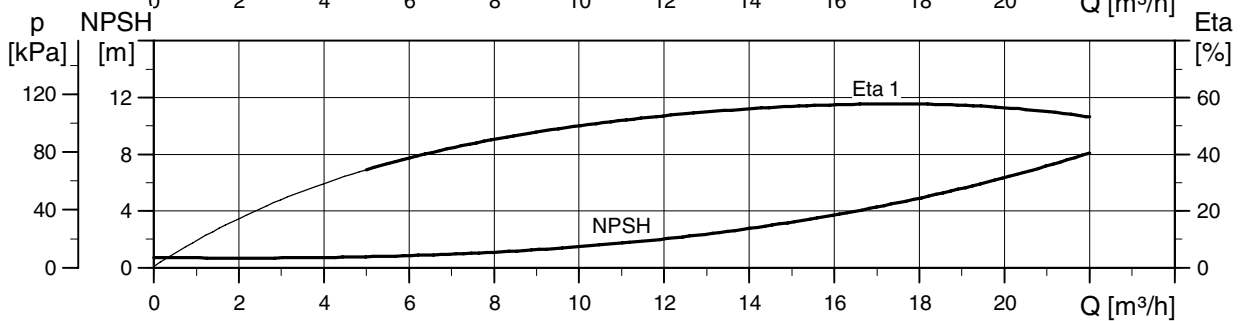
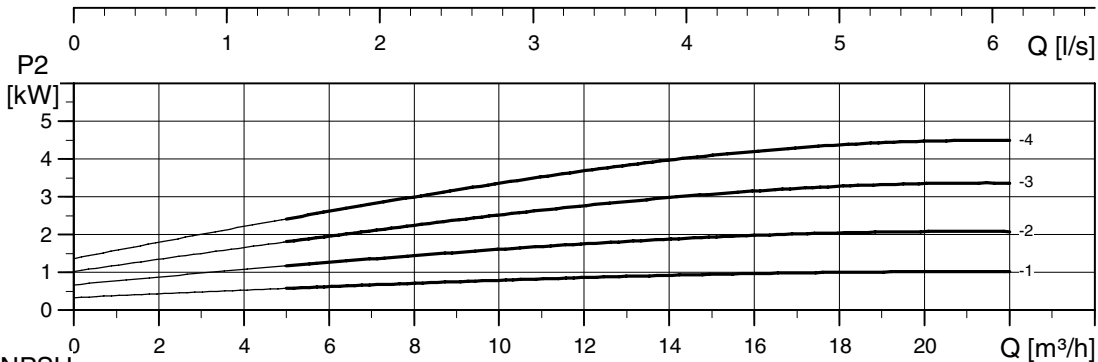
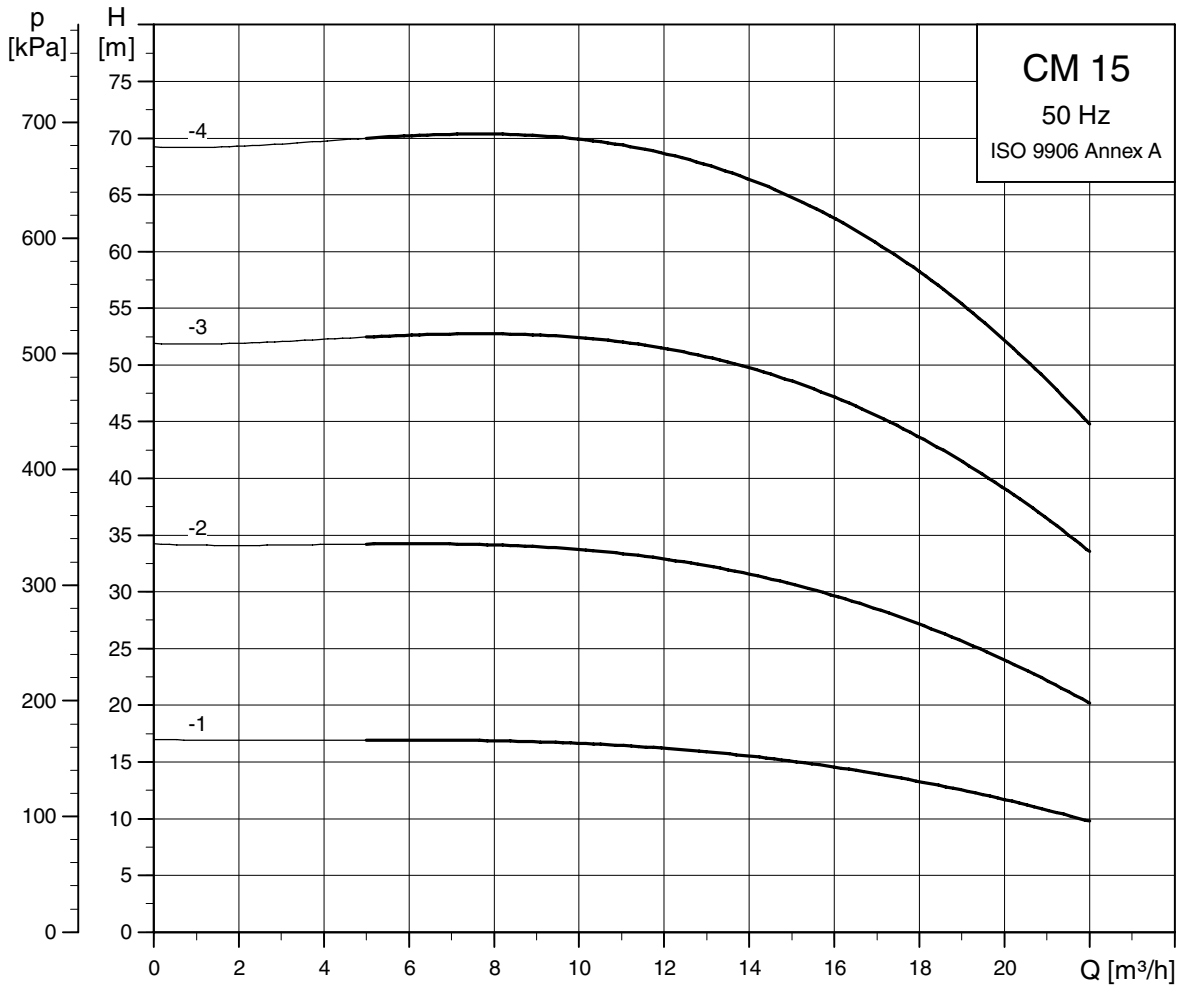

TM04 3338 4308

Performance curves, CM 50 Hz

CM 25
50 Hz

CM 25

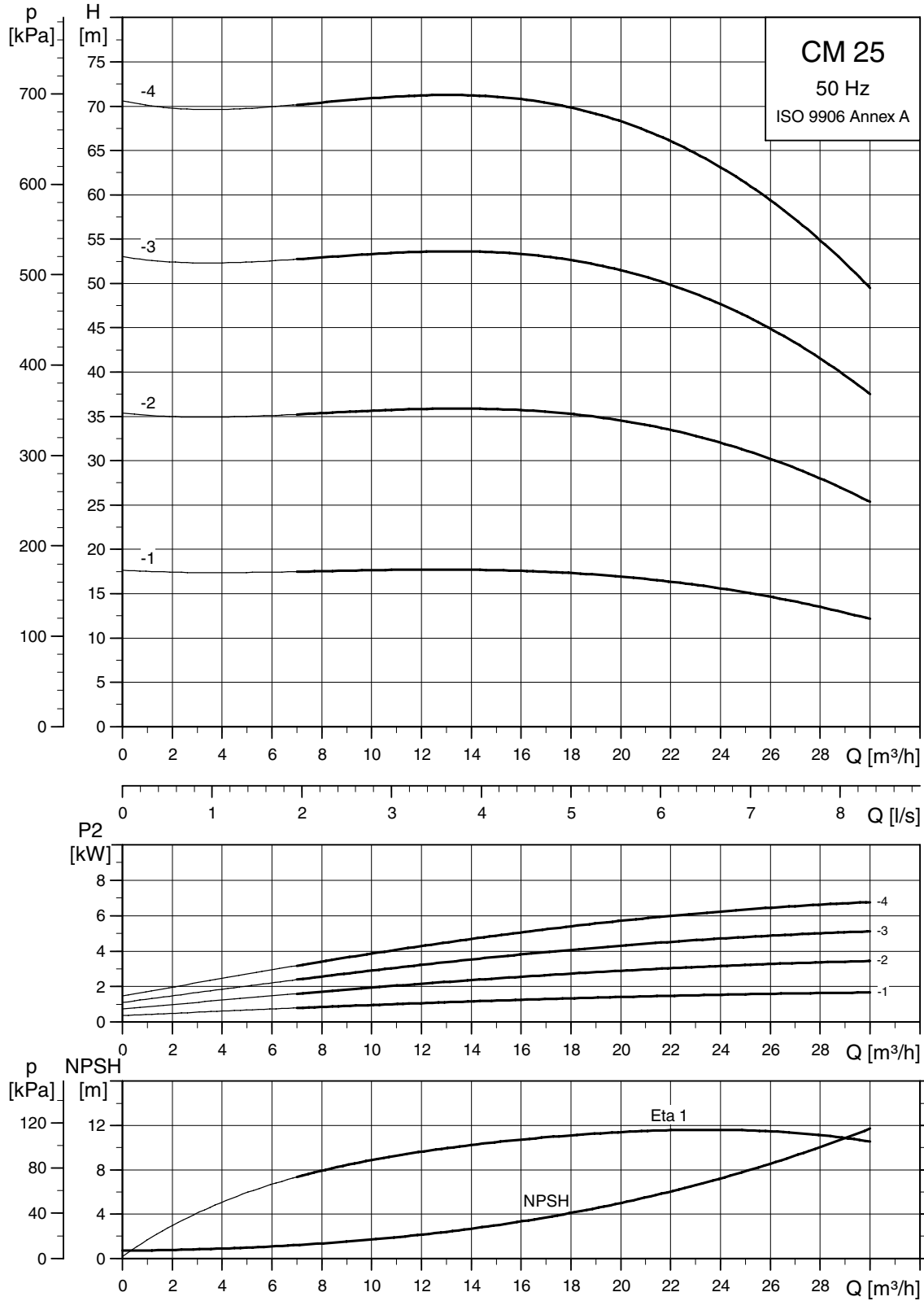

TM04 3339 4308

Performance curves, CM 60 Hz

CM 1
60 Hz

CM 1

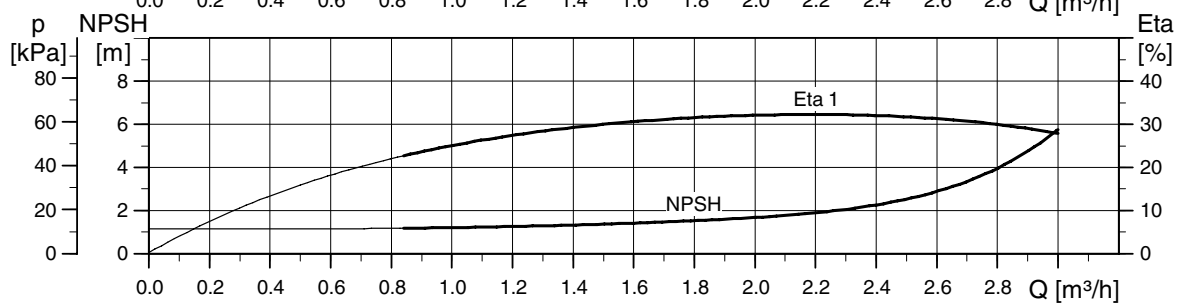
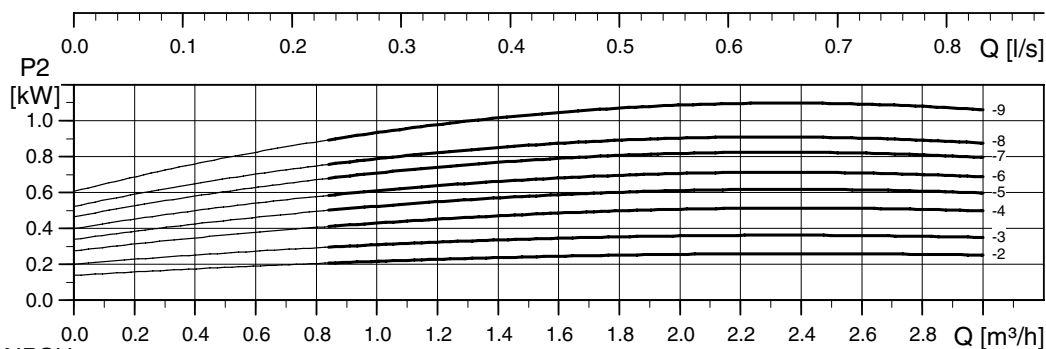
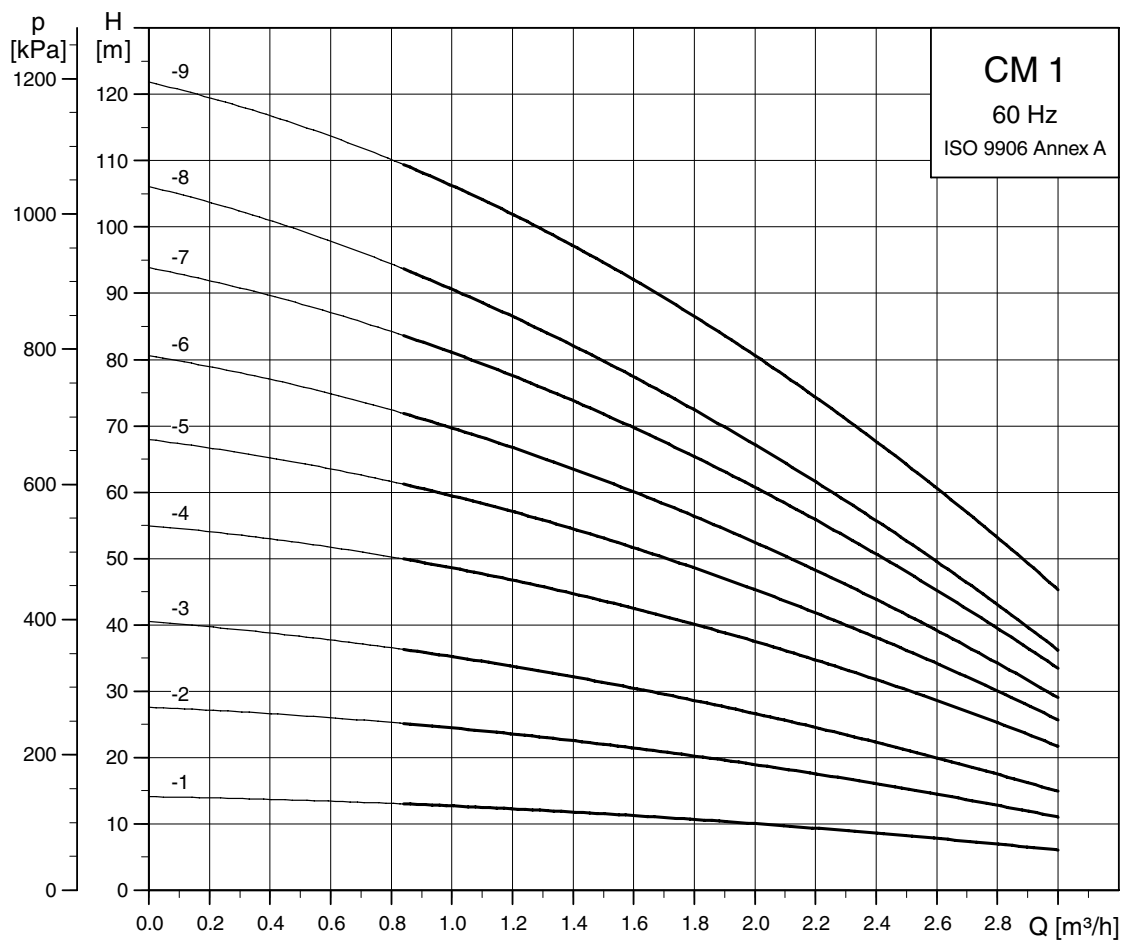

TM04 3370 4308

Performance curves, CM 60 Hz

CM 3
60 Hz

CM 3

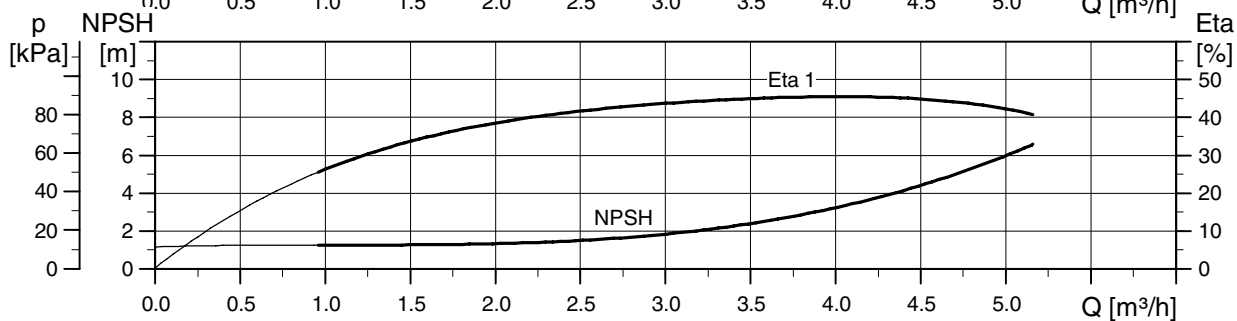
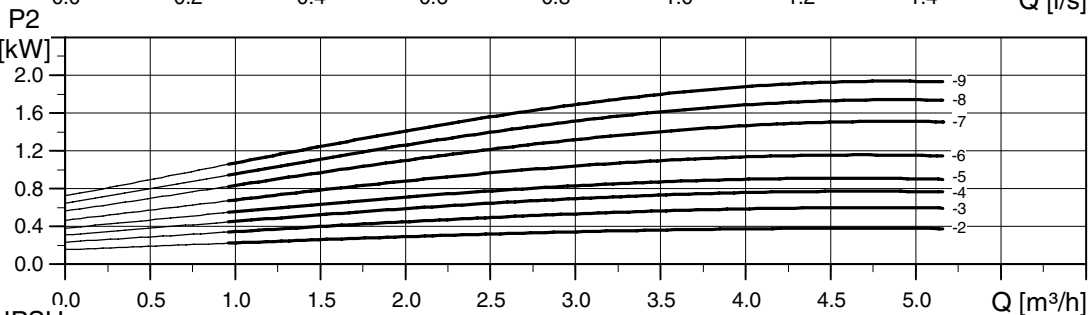
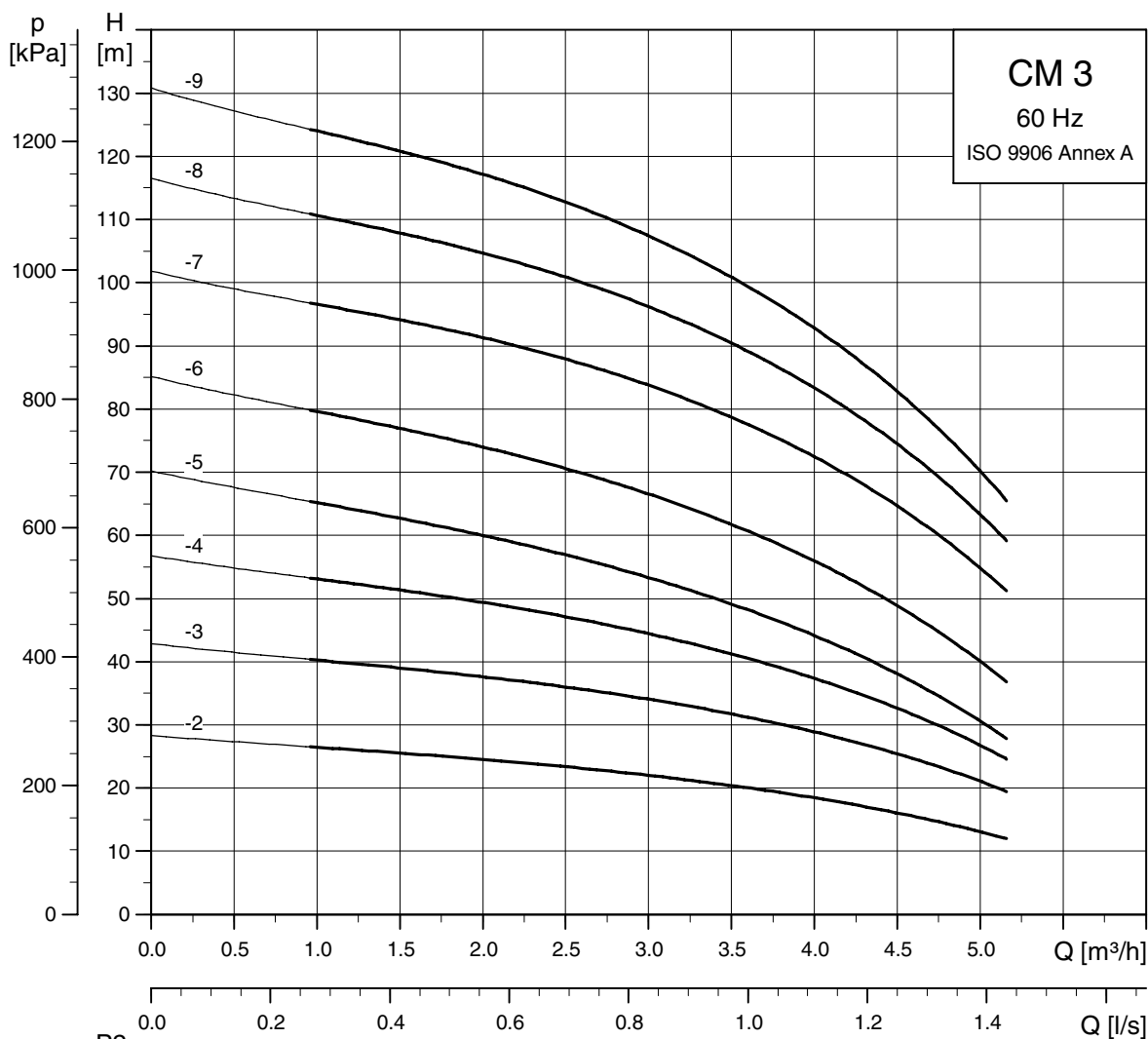

TM04 3371 4308

Performance curves, CM 60 Hz

CM 5
60 Hz

CM 5

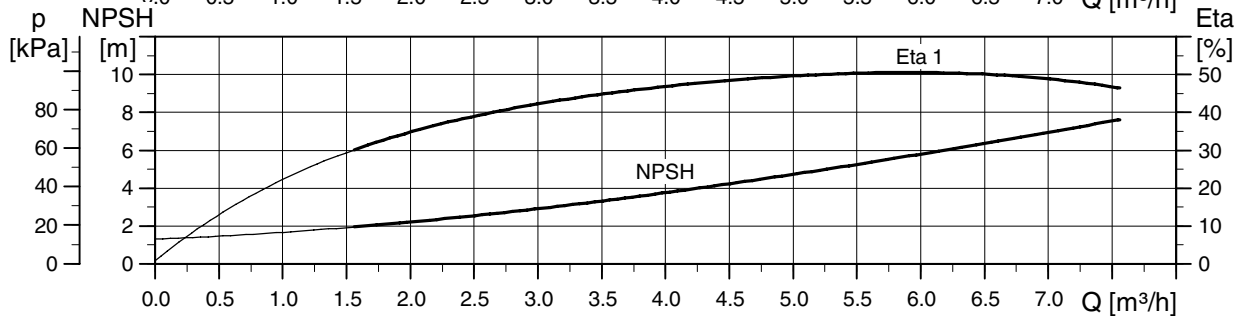
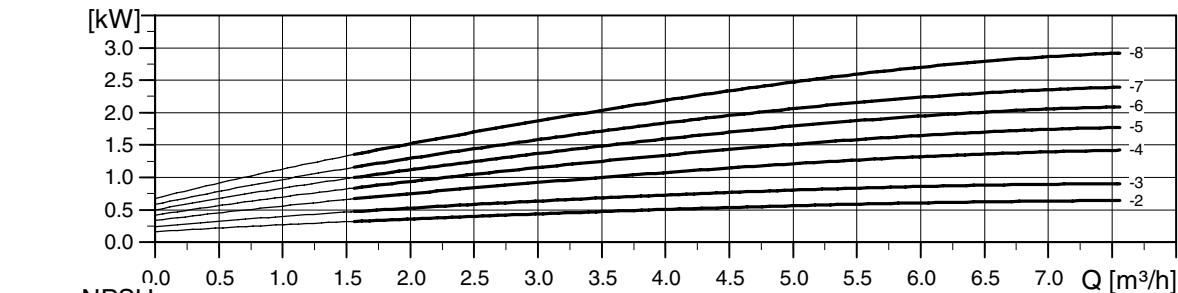
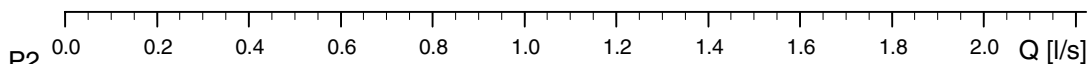
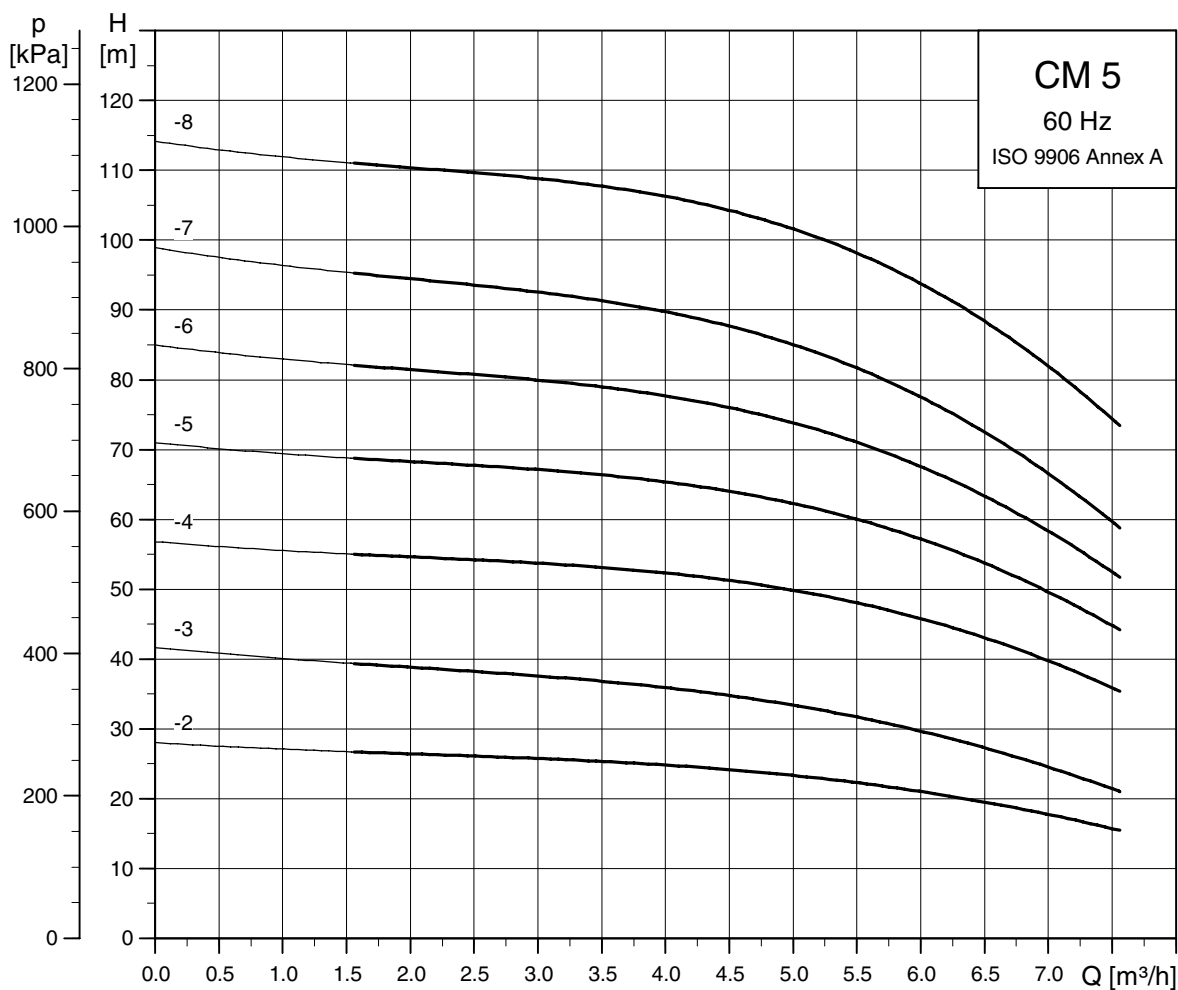

TM04 3372 4308

Performance curves, CM 60 Hz

CM 10
60 Hz

CM 10

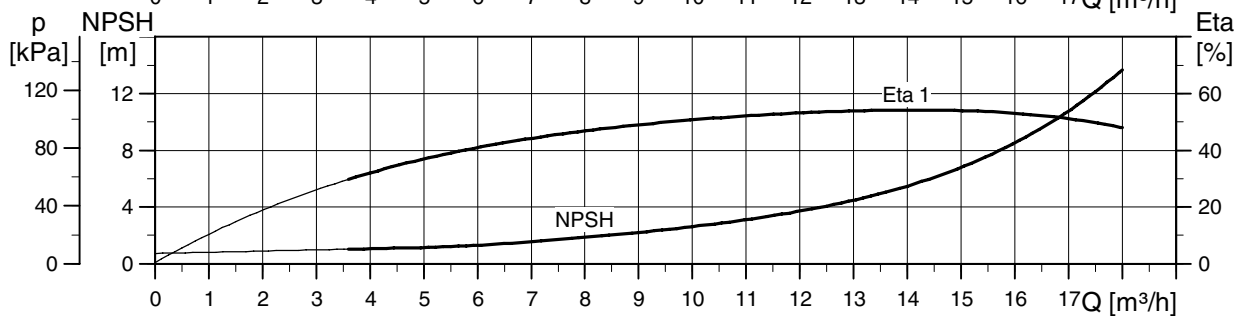
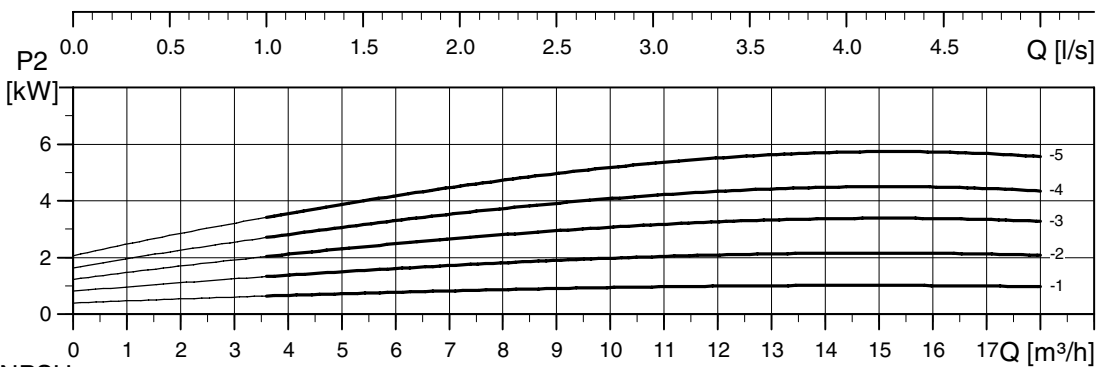
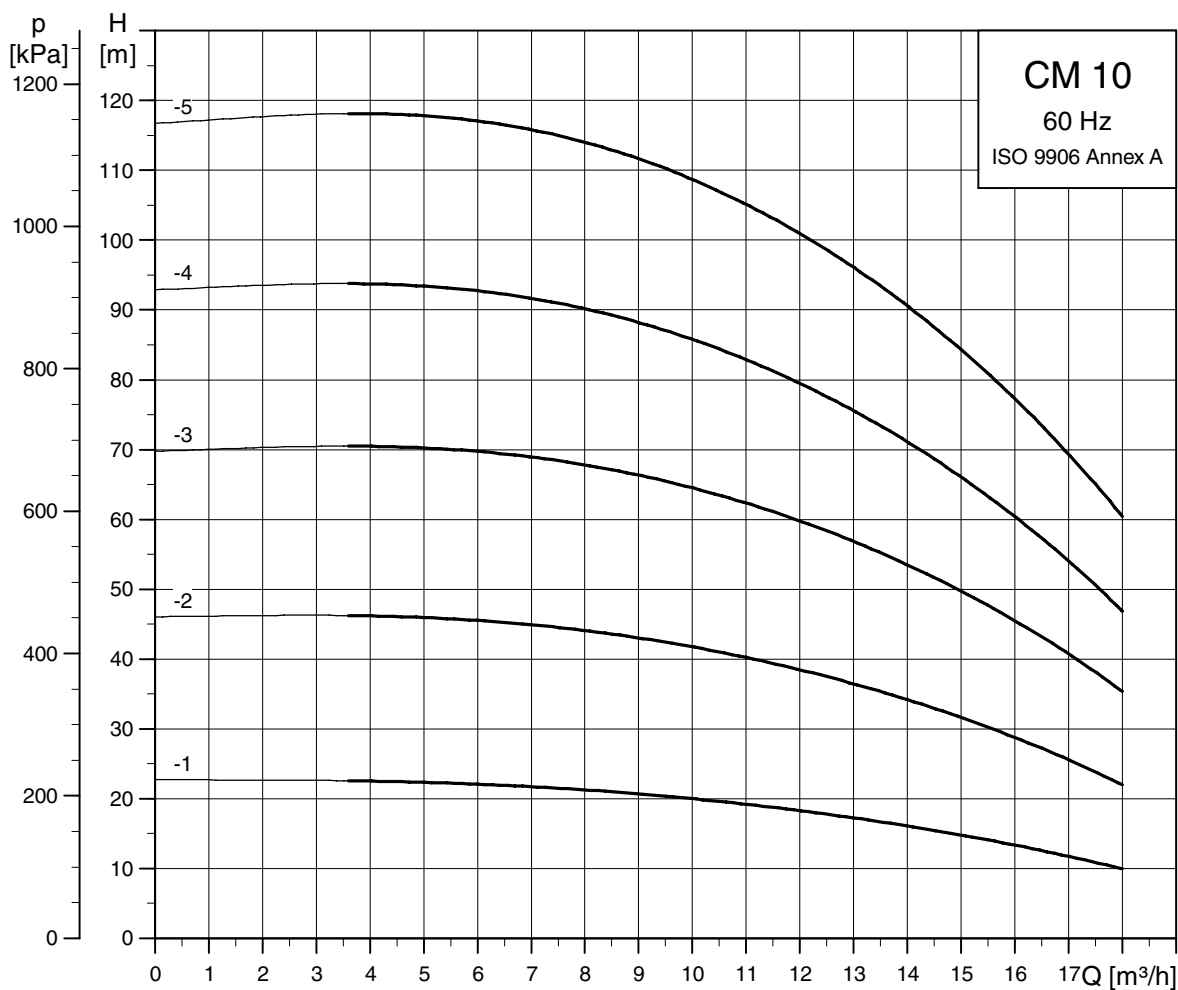

TMD4 3373 4308

Performance curves, CM 60 Hz

CM 15
60 Hz

CM 15

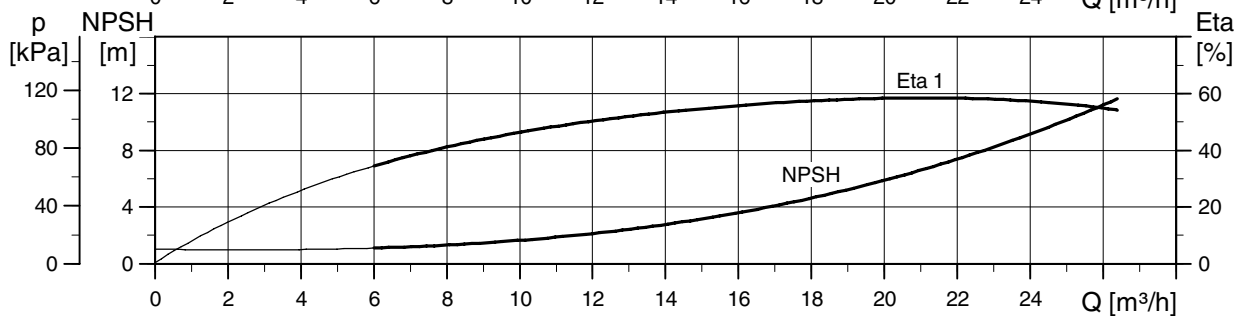
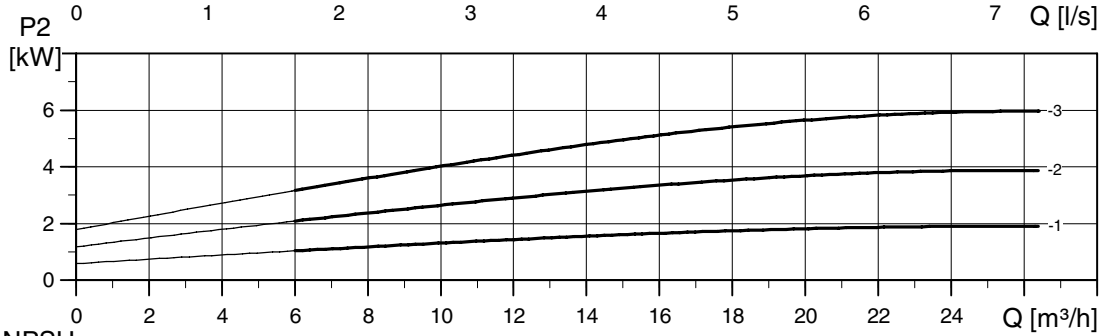
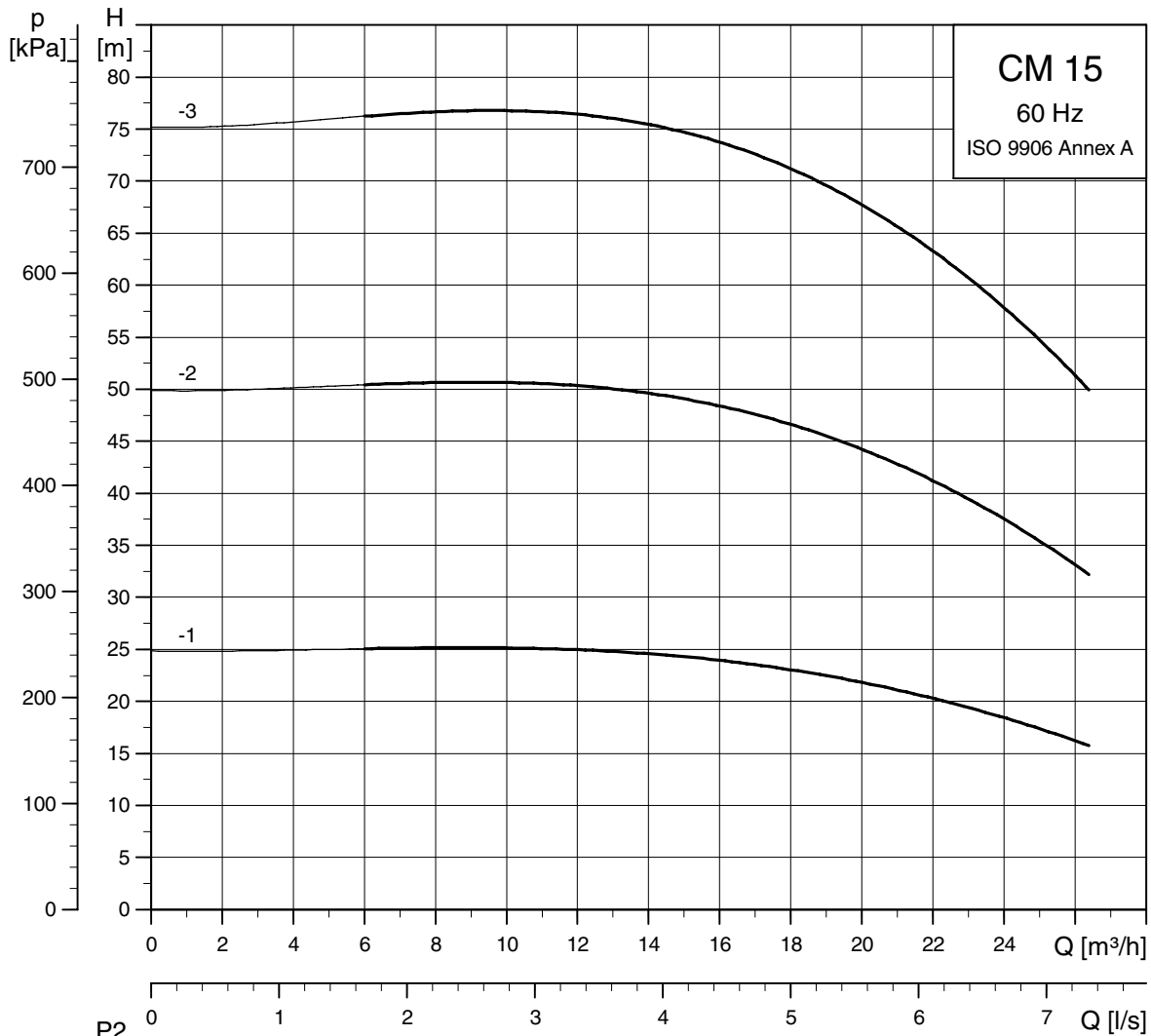

TM04 3374 4308

Performance curves, CM 60 Hz

CM 25
60 Hz

CM 25

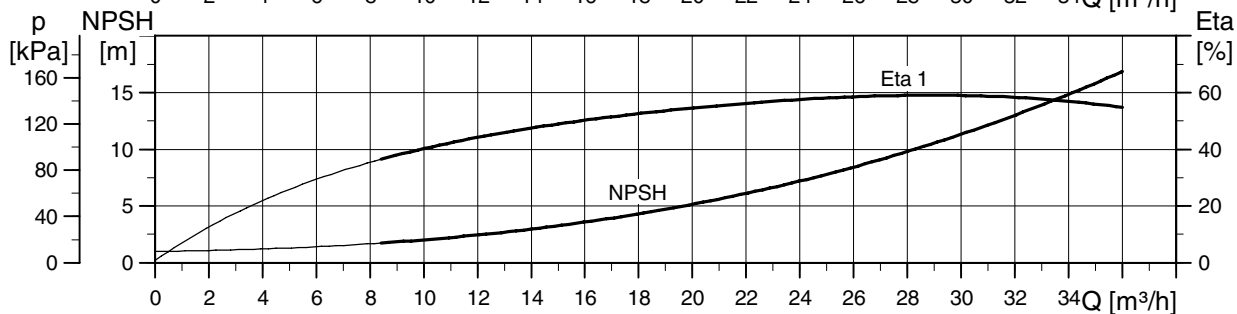
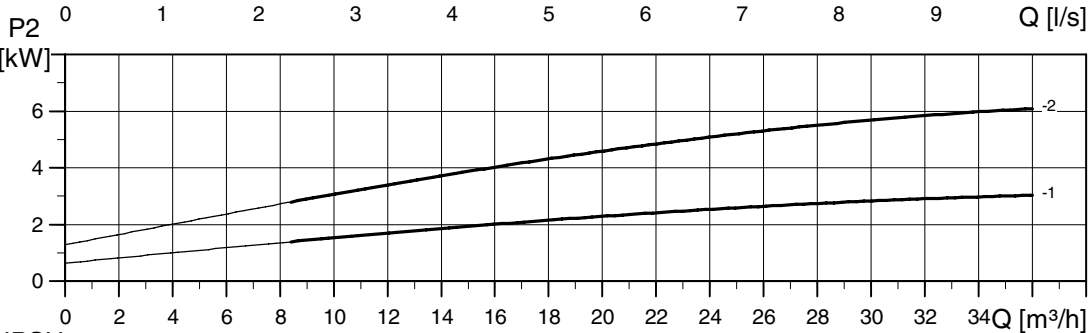
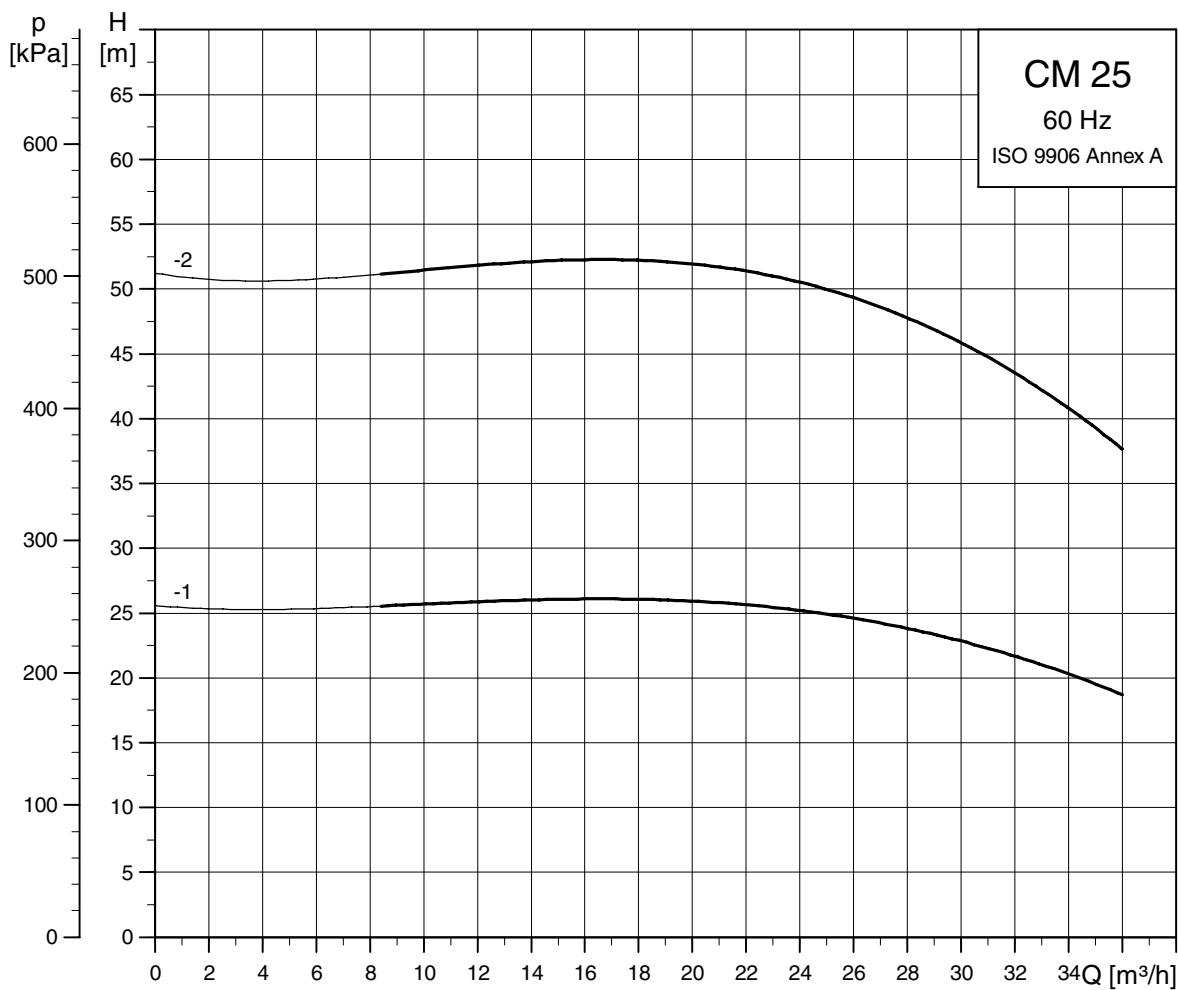

TM04 3375 4308

Performance curves, CME 50/60 Hz

CME 1
50/60 Hz

CME 1

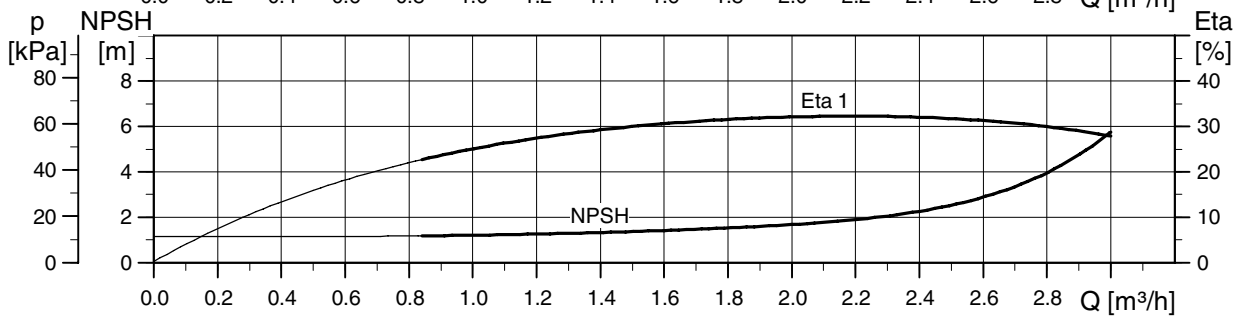
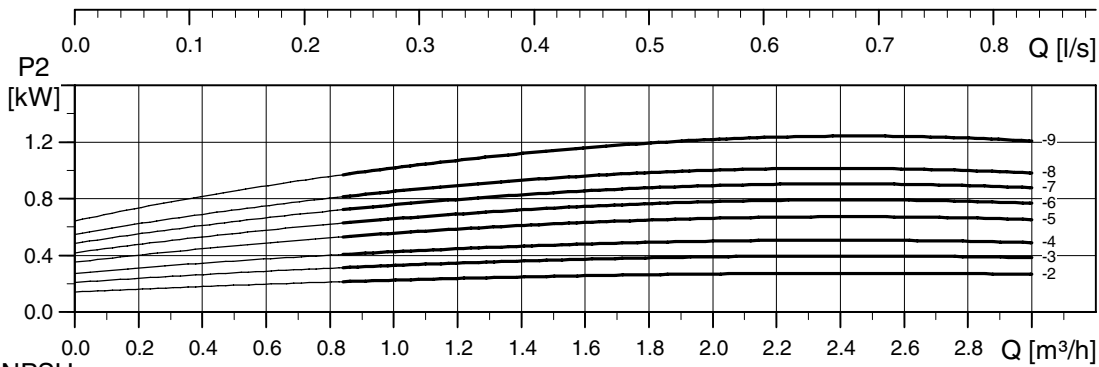
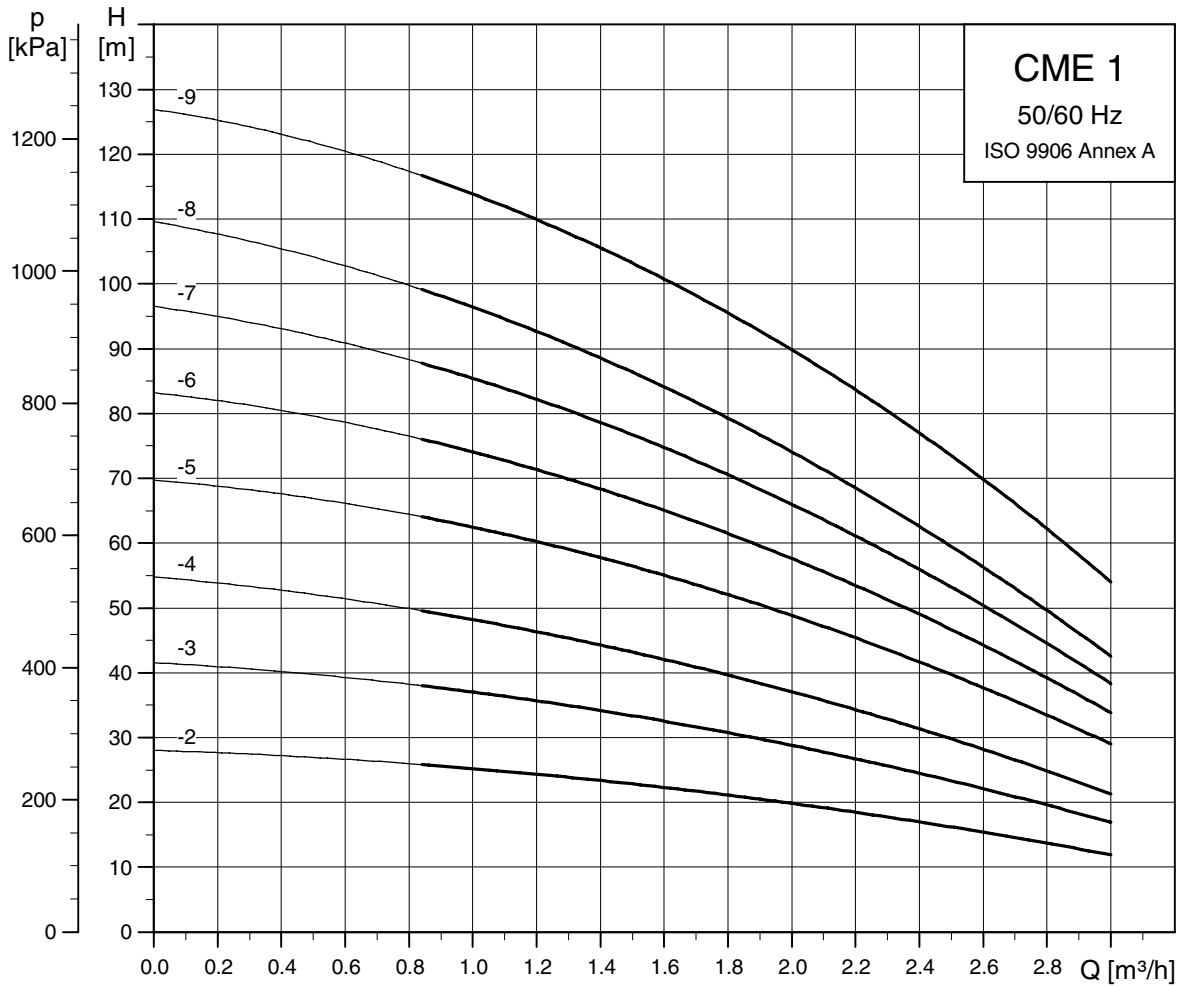

TM04 3569 4608

Performance curves, CME 50/60 Hz

CME 3
50/60 Hz

CME 3

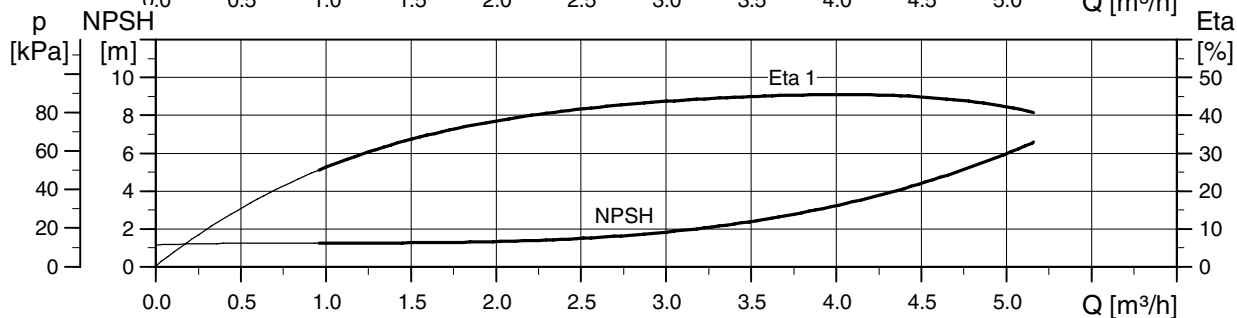
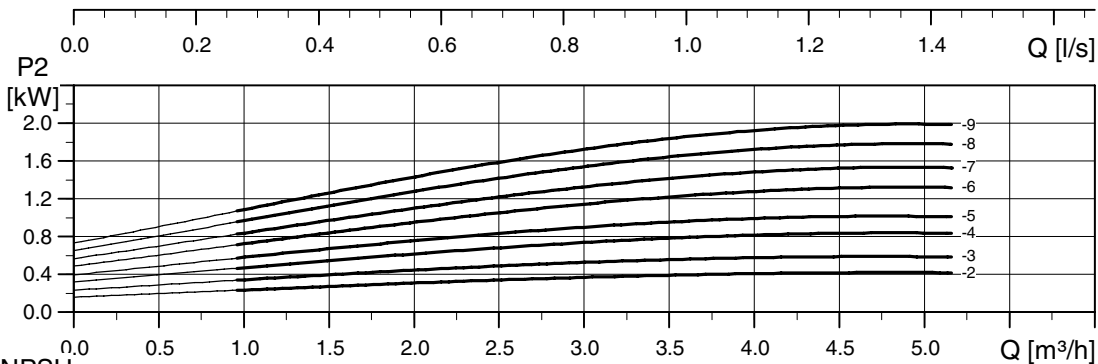
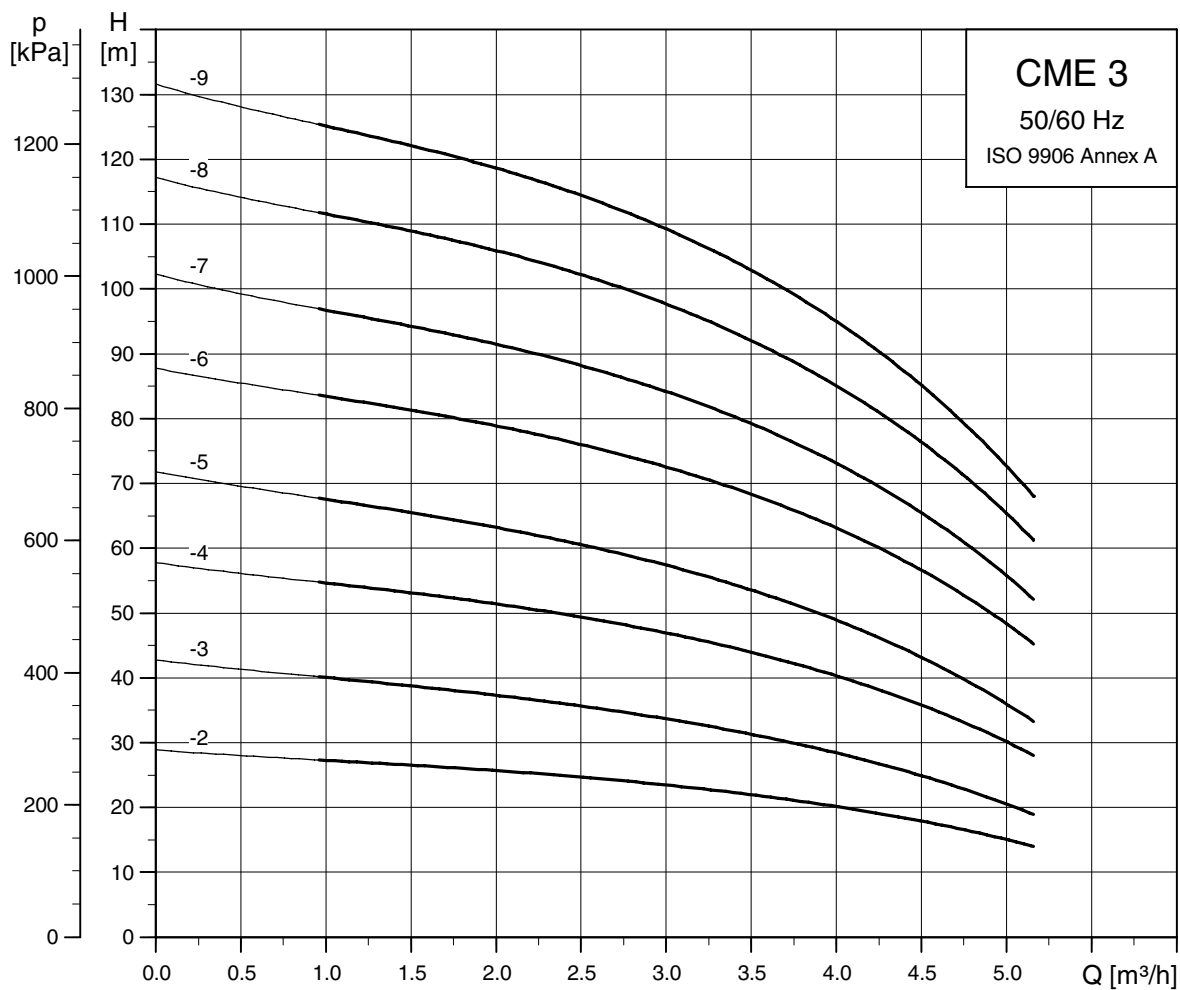

TMD4 3570 4608

Performance curves, CME 50/60 Hz

CME 5
50/60 Hz

CME 5

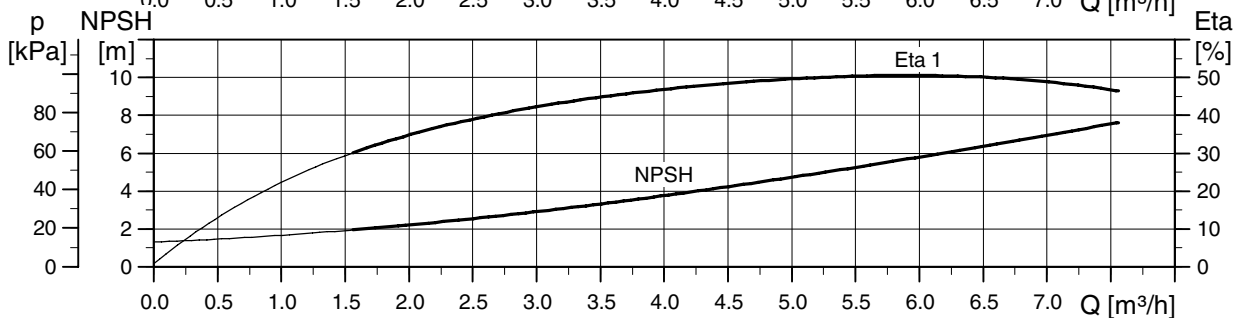
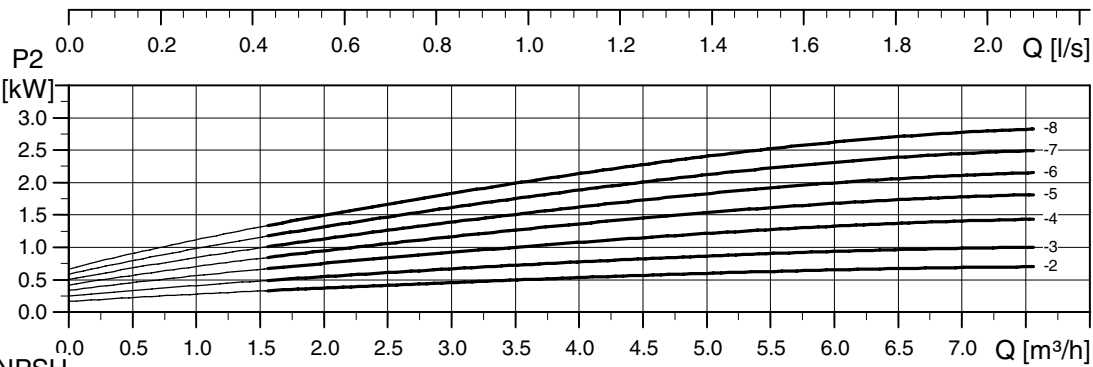
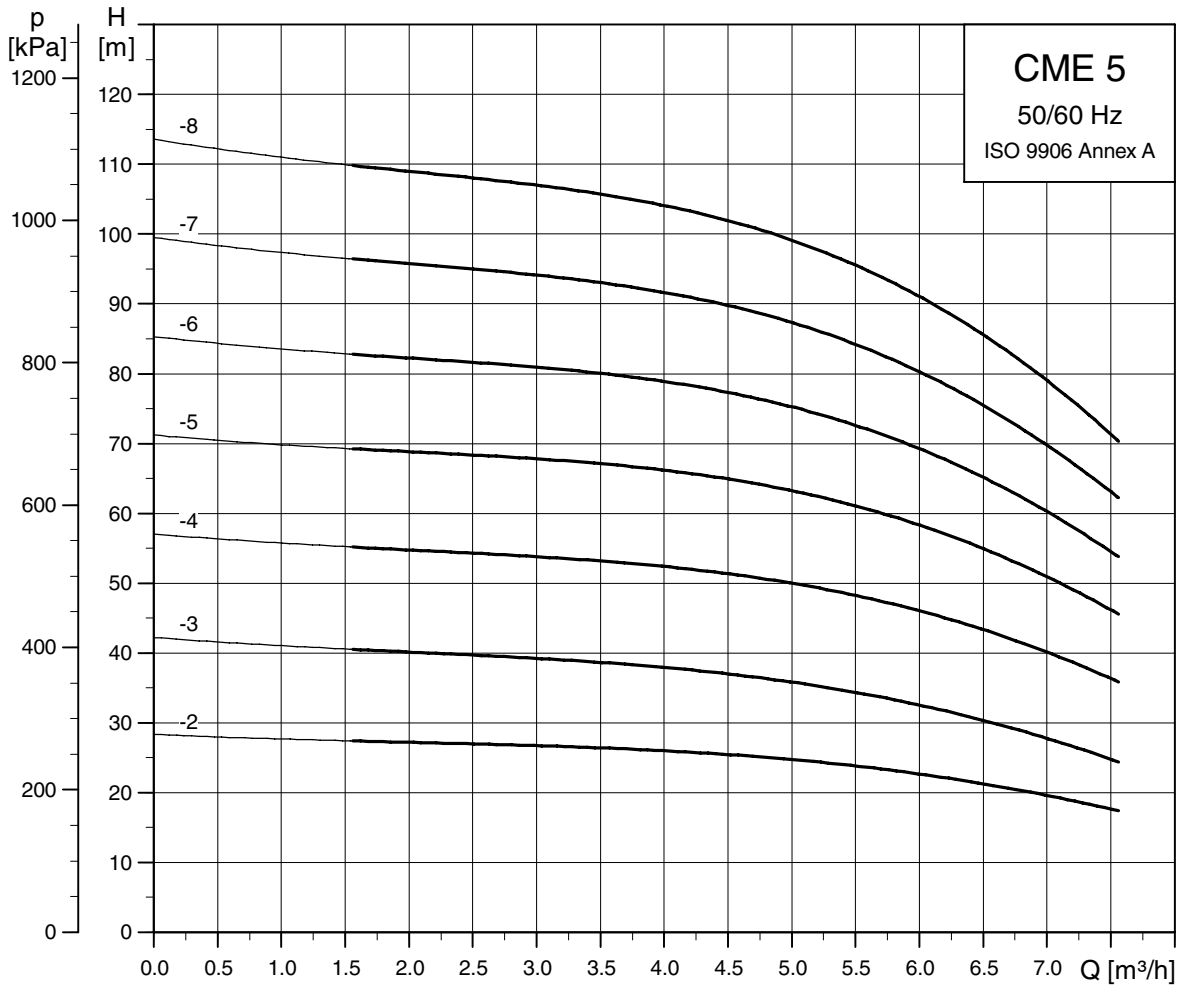

TM04 3571 4608

Performance curves, CME

50/60 Hz

CME 10
50/60 Hz

CME 10

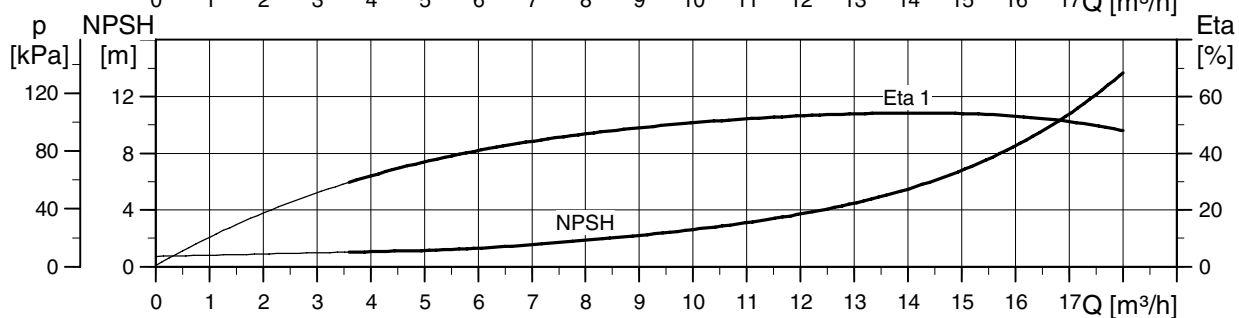
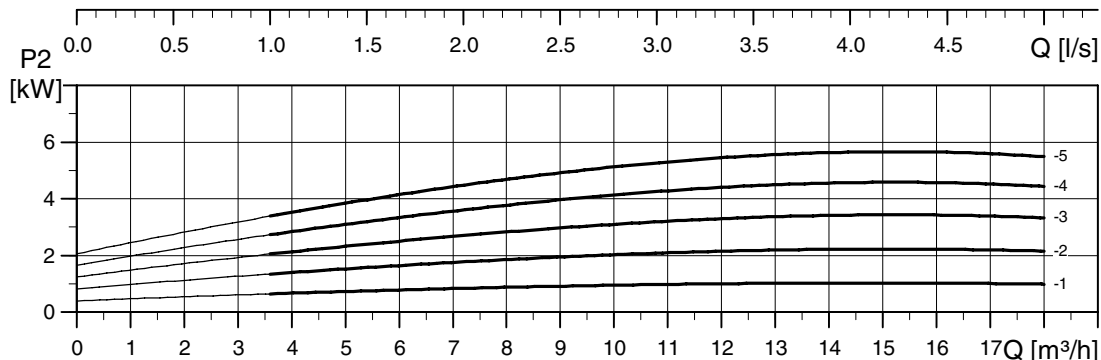
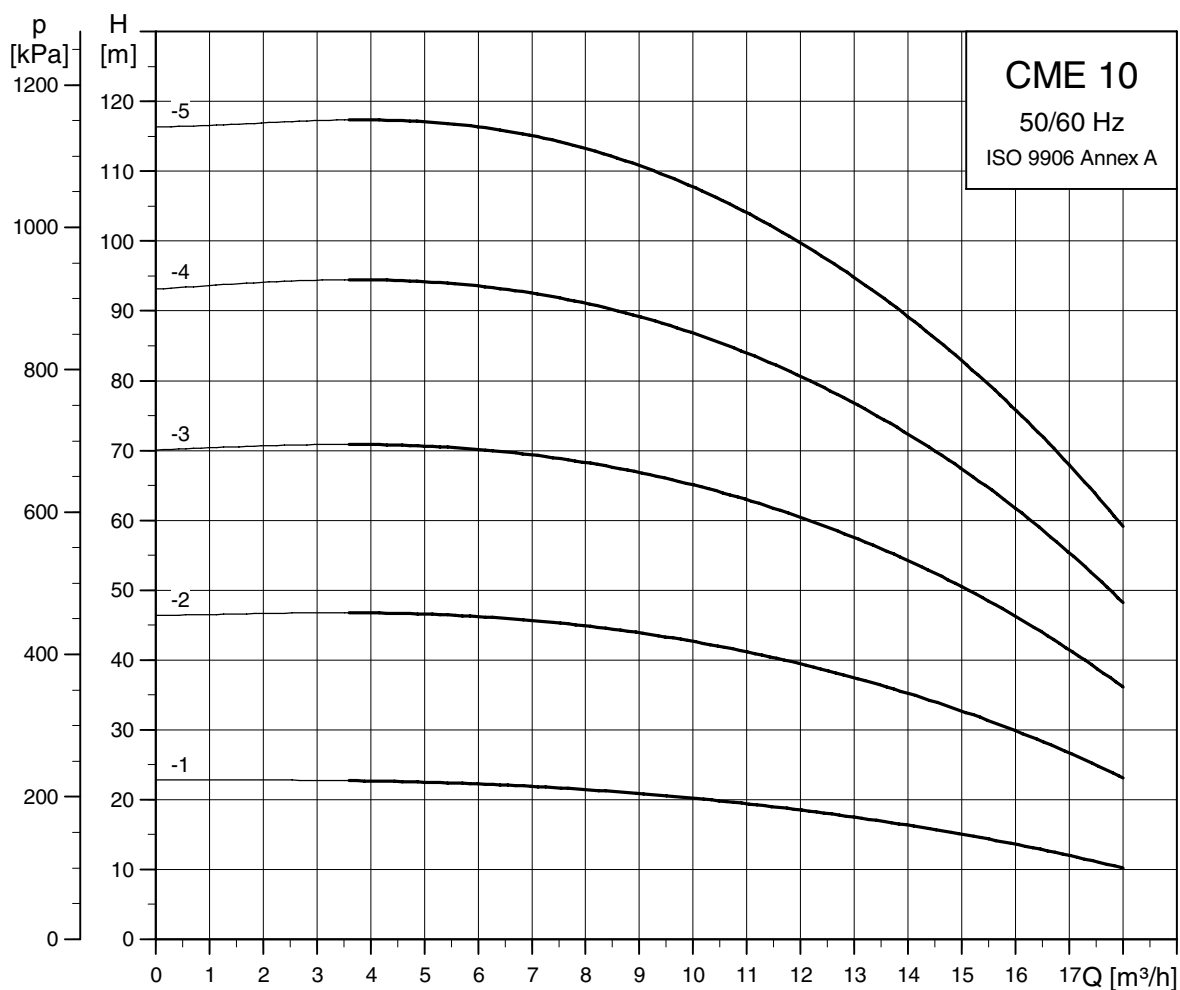

TM04 3572 4608

Performance curves, CME 50/60 Hz

CME 15
50/60 Hz

CME 15

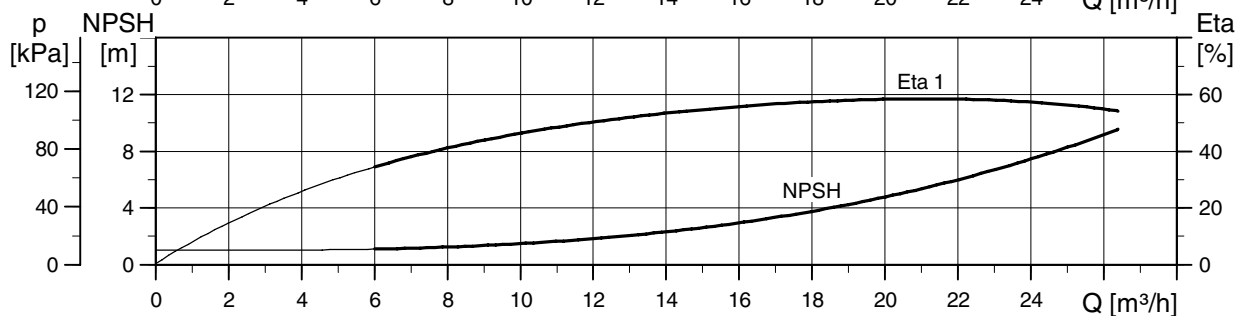
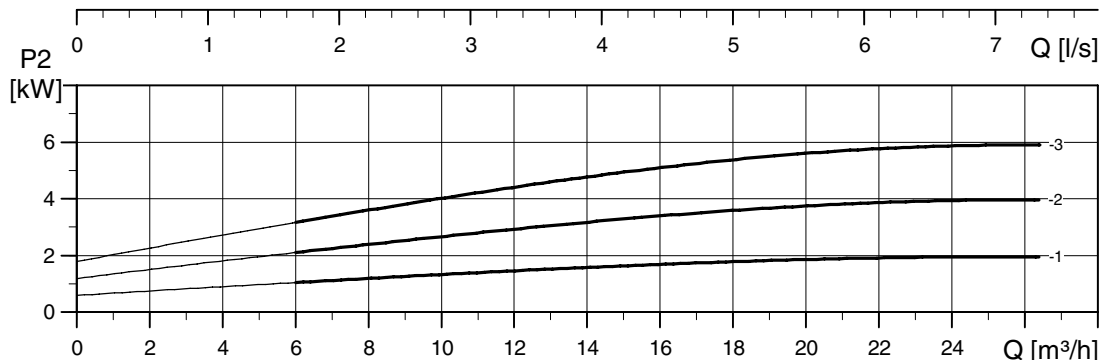
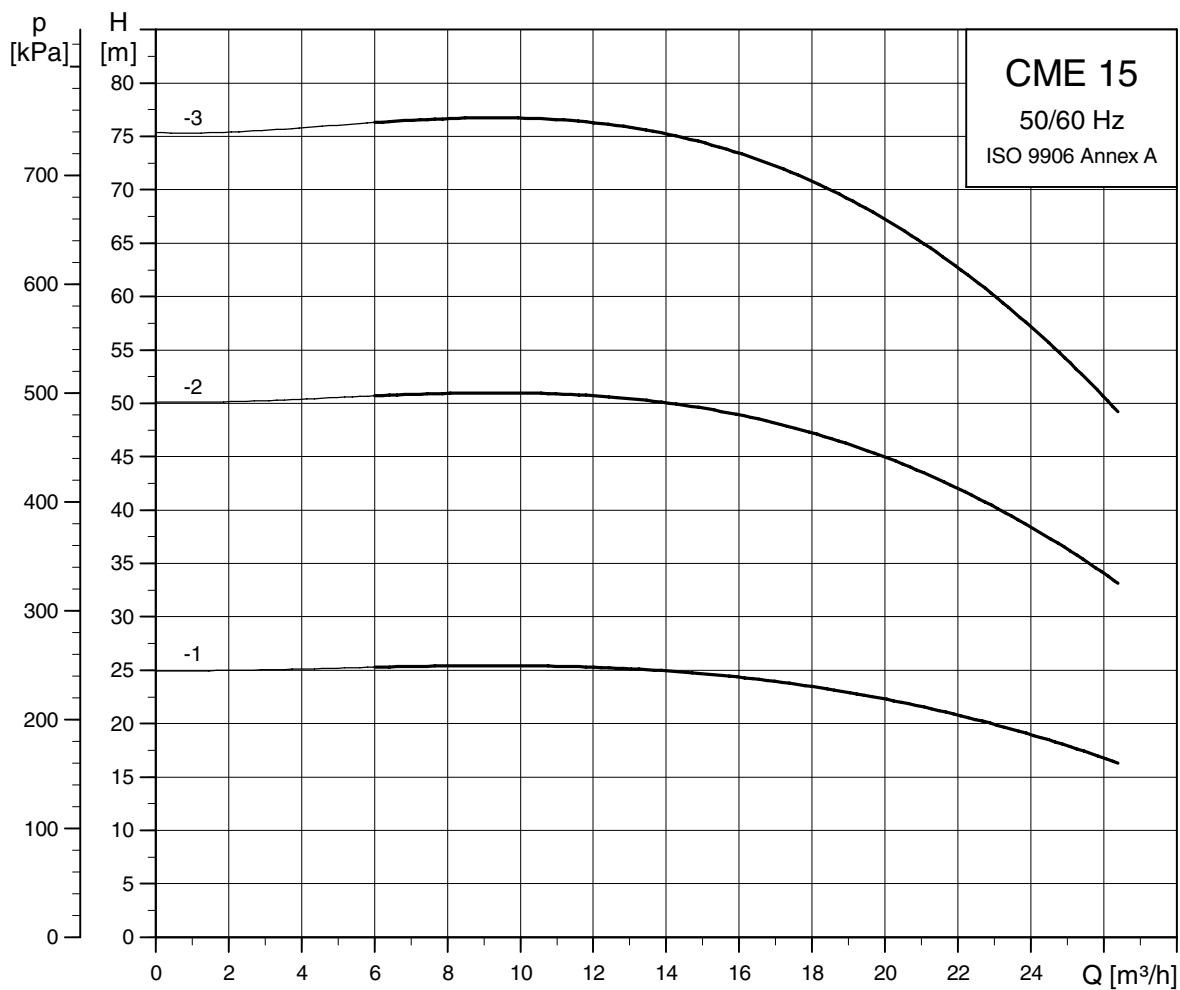

TM04 3573 4608

Performance curves, CME 50/60 Hz

CME 25
50/60 Hz

CME 25

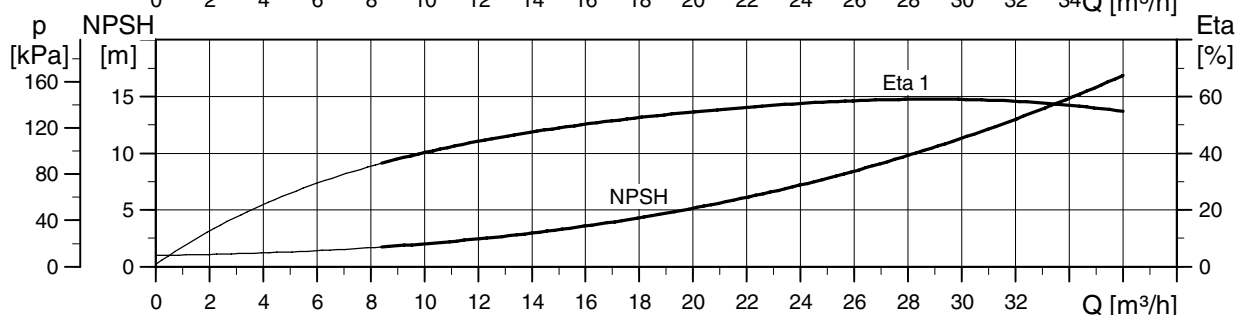
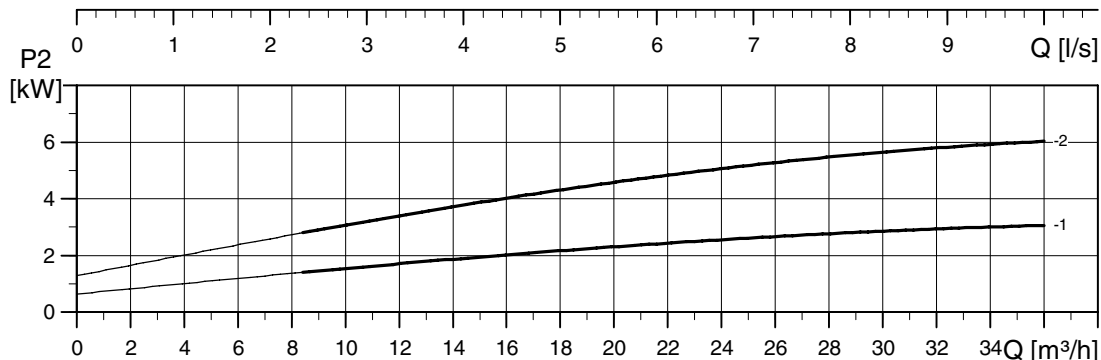
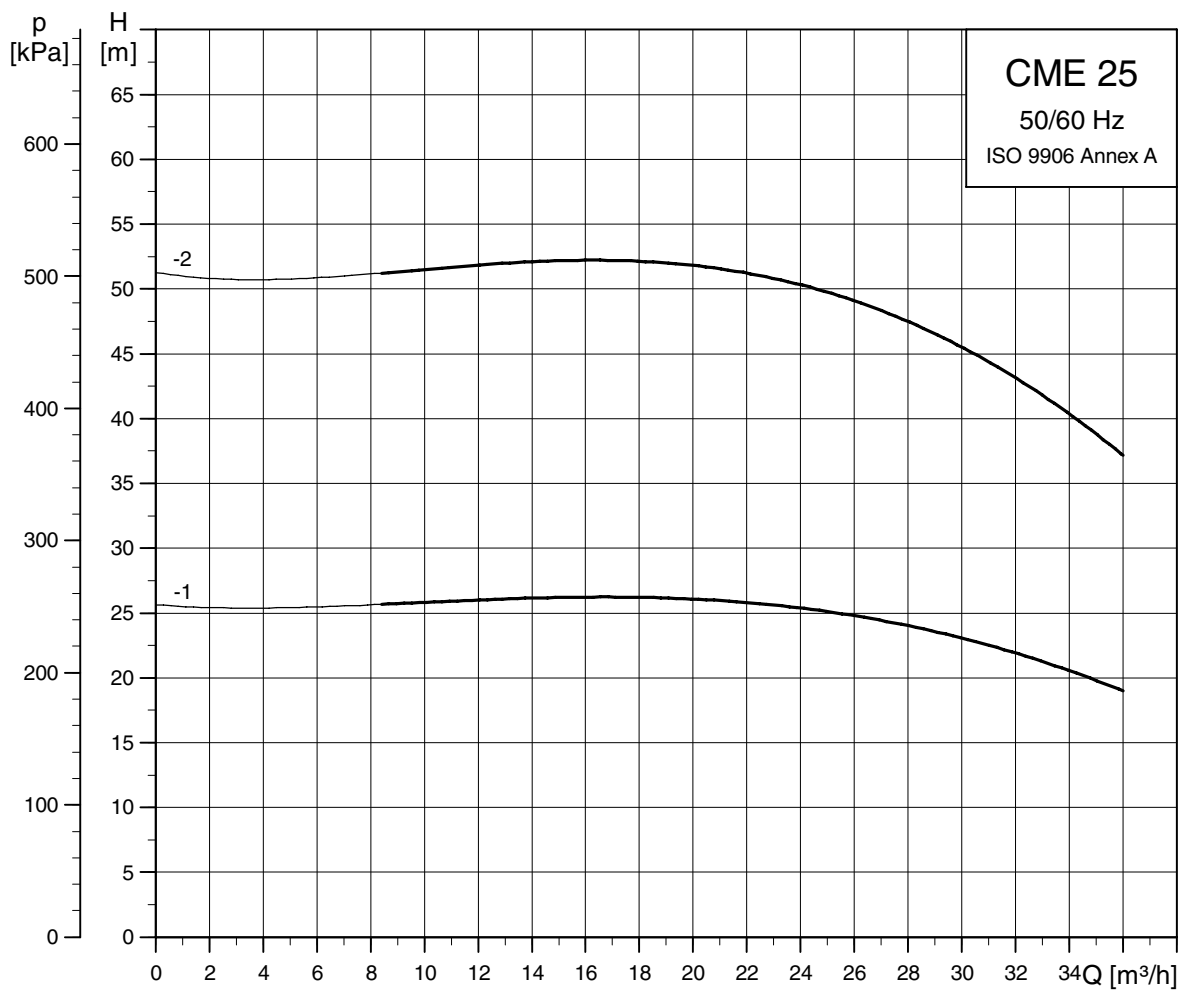

TMD4 3574 4608

Dimensions, CM 50 Hz

CM 1-A
50 Hz

CM 1-A

(A = cast iron, EN-GJL-200)

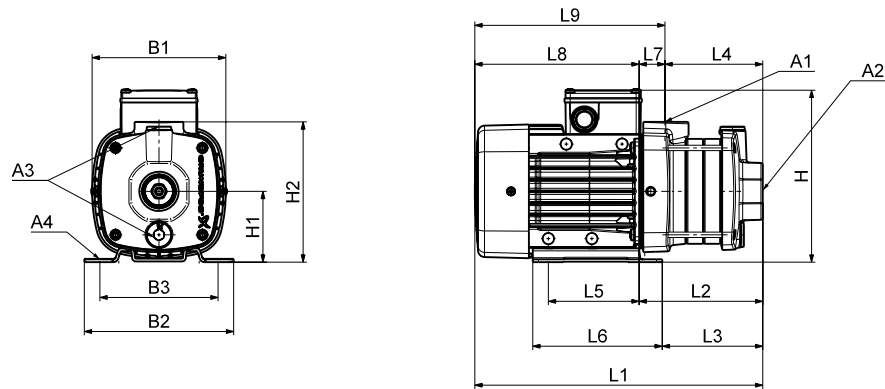

TM04 22:48 2208

Dimensions

3 x 220-240 V / 380-415 V, 50 Hz (supply voltage F)

Pump type	Frame size	P ₂ [kW]	Dimensions [mm]																		
			A1	A2	A3	A4	B1	B2	B3	H	H1	H2	L1	L2	L3	L4	L5	L6	L7	L8	L9
CM 1-2	71	0.45	1"	1"	3/8"	10	142	158	125	184	75	149	288	114	89	86	96	137	28	174	202
CM 1-3	71	0.45	1"	1"	3/8"	10	142	158	125	184	75	149	306	132	107	104	96	137	28	174	202
CM 1-4	71	0.45	1"	1"	3/8"	10	142	158	125	184	75	149	324	150	125	122	96	137	28	174	202
CM 1-5	71	0.45	1"	1"	3/8"	10	142	158	125	184	75	149	342	168	143	140	96	137	28	174	202
CM 1-6	71	0.45	1"	1"	3/8"	10	142	158	125	184	75	149	360	186	161	158	96	137	28	174	202
CM 1-7	71	0.65	1"	1"	3/8"	10	142	158	125	184	75	149	378	204	179	176	96	137	28	174	202
CM 1-8	71	0.65	1"	1"	3/8"	10	142	158	125	184	75	149	396	222	197	194	96	137	28	174	202

1 x 220-240 V, 50 Hz (supply voltage C)

Pump type	Frame size	P ₂ [kW]	Dimensions [mm]																		
			A1	A2	A3	A4	B1	B2	B3	H	H1	H2	L1	L2	L3	L4	L5	L6	L7	L8	L9
CM 1-2	71	0.30	1"	1"	3/8"	10	142	158	125	208	75	149	288	114	89	86	96	137	28	174	202
CM 1-3	71	0.30	1"	1"	3/8"	10	142	158	125	208	75	149	306	132	107	104	96	137	28	174	202
CM 1-4	71	0.50	1"	1"	3/8"	10	142	158	125	208	75	149	324	150	125	122	96	137	28	174	202
CM 1-5	71	0.50	1"	1"	3/8"	10	142	158	125	208	75	149	342	168	143	140	96	137	28	174	202
CM 1-6	71	0.50	1"	1"	3/8"	10	142	158	125	208	75	149	360	186	161	158	96	137	28	174	202
CM 1-7	71	0.50	1"	1"	3/8"	10	142	158	125	208	75	149	378	204	179	176	96	137	28	174	202
CM 1-8	80	0.67	1"	1"	3/8"	10	142	158	125	208	75	149	436	222	197	194	96	137	28	214	242

Dimensions, CM 50 Hz

CM 1-A
50 Hz

CM 1-I and CM 1-G

(I = EN 1.4301/AISI 304 and G = EN 1.4401/AISI 316)

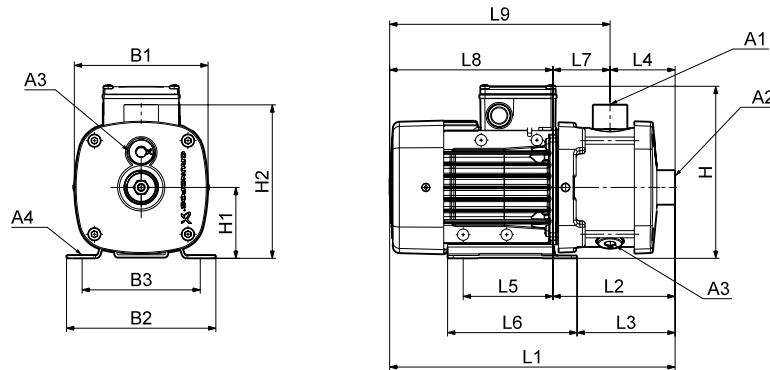

TM04 2246 2208

Dimensions

3 x 220-240 V / 380-415 V, 50 Hz (supply voltage F)

Pump type	Frame size	P ₂ [kW]	Dimensions [mm]																		
			A1	A2	A3	A4	B1	B2	B3	H	H1	H2	L1	L2	L3	L4	L5	L6	L7	L8	L9
CM 1-2	71	0.45	1"	1"	3/8"	10	142	158	125	184	75	165	305	131	107	72	96	137	60	174	234
CM 1-3	71	0.45	1"	1"	3/8"	10	142	158	125	184	75	165	305	131	107	72	96	137	60	174	234
CM 1-4	71	0.45	1"	1"	3/8"	10	142	158	125	184	75	165	323	149	125	90	96	137	60	174	234
CM 1-5	71	0.45	1"	1"	3/8"	10	142	158	125	184	75	165	341	167	143	108	96	137	60	174	234
CM 1-6	71	0.45	1"	1"	3/8"	10	142	158	125	184	75	165	377	203	179	144	96	137	60	174	234
CM 1-7	71	0.65	1"	1"	3/8"	10	142	158	125	184	75	165	377	203	179	144	96	137	60	174	234
CM 1-8	71	0.65	1"	1"	3/8"	10	142	158	125	184	75	165	413	239	215	180	96	137	60	174	234
CM 1-9*	71	0.65	1"	1"	3/8"	10	142	158	125	184	75	165	413	239	215	180	96	137	60	174	234
CM 1-10*	80	0.84	1"	1"	3/8"	10	142	158	125	184	75	165	489	275	251	216	96	137	60	214	274
CM 1-11*	80	0.84	1"	1"	3/8"	10	142	158	125	184	75	165	489	275	251	216	96	137	60	214	274
CM 1-12*	80	0.84	1"	1"	3/8"	10	142	158	125	184	75	165	543	329	305	270	96	137	60	214	274
CM 1-13*	80	1.20	1"	1"	3/8"	10	142	158	125	184	75	165	543	329	305	270	96	137	60	214	274
CM 1-14*	80	1.20	1"	1"	3/8"	10	142	158	125	184	75	165	543	329	305	270	96	137	60	214	274

* Only CM-G versions are available with this number of stages.

1 x 220-240 V, 50 Hz (supply voltage C)

Pump type	Frame size	P ₂ [kW]	Dimensions [mm]																		
			A1	A2	A3	A4	B1	B2	B3	H	H1	H2	L1	L2	L3	L4	L5	L6	L7	L8	L9
CM 1-2	71	0.30	1"	1"	3/8"	10	142	158	125	208	75	165	305	131	107	72	96	137	60	174	234
CM 1-3	71	0.30	1"	1"	3/8"	10	142	158	125	208	75	165	305	131	107	72	96	137	60	174	234
CM 1-4	71	0.50	1"	1"	3/8"	10	142	158	125	208	75	165	323	149	125	90	96	137	60	174	234
CM 1-5	71	0.50	1"	1"	3/8"	10	142	158	125	208	75	165	341	167	143	108	96	137	60	174	234
CM 1-6	71	0.50	1"	1"	3/8"	10	142	158	125	208	75	165	377	203	179	144	96	137	60	174	234
CM 1-7	71	0.50	1"	1"	3/8"	10	142	158	125	208	75	165	377	203	179	144	96	137	60	174	234
CM 1-8	80	0.67	1"	1"	3/8"	10	142	158	125	208	75	165	453	239	215	180	96	137	60	214	274
CM 1-9*	80	0.67	1"	1"	3/8"	10	142	158	125	208	75	165	453	239	215	180	96	137	60	214	274
CM 1-10*	80	0.67	1"	1"	3/8"	10	142	158	125	208	75	165	489	275	251	216	96	137	60	214	274
CM 1-11*	80	0.90	1"	1"	3/8"	10	142	158	125	208	75	165	489	275	251	216	96	137	60	214	274
CM 1-12*	80	0.90	1"	1"	3/8"	10	142	158	125	208	75	165	543	329	305	270	96	137	60	214	274
CM 1-13*	80	0.90	1"	1"	3/8"	10	142	158	125	208	75	165	543	329	305	270	96	137	60	214	274
CM 1-14*	90	1.30	1"	1"	3/8"	10	178	178	140	229	90	180	593	369	354	270	125	155	99	224	323

* Only CM-G versions are available with this number of stages.

Dimensions, CM 50 Hz

CM 3-A
50 Hz

CM 3-A

(A = cast iron, EN-GJL-200)

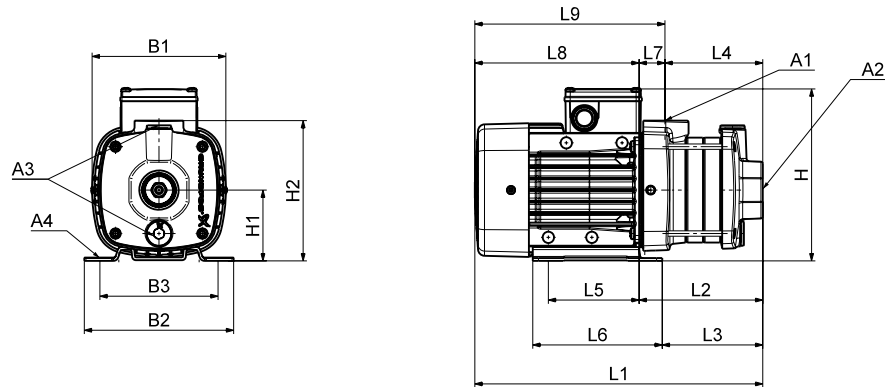

TM04 2248 2208

Dimensions

3 x 220-240 V / 380-415 V, 50 Hz (supply voltage F)

Pump type	Frame size	P ₂ [kW]	Dimensions [mm]																		
			A1	A2	A3	A4	B1	B2	B3	H	H1	H2	L1	L2	L3	L4	L5	L6	L7	L8	L9
CM 3-2	71	0.45	1"	1"	3/8"	10	142	158	125	184	75	149	288	114	89	86	96	137	28	174	202
CM 3-3	71	0.45	1"	1"	3/8"	10	142	158	125	184	75	149	306	132	107	104	96	137	28	174	202
CM 3-4	71	0.45	1"	1"	3/8"	10	142	158	125	184	75	149	324	150	125	122	96	137	28	174	202
CM 3-5	71	0.65	1"	1"	3/8"	10	142	158	125	184	75	149	342	168	143	140	96	137	28	174	202
CM 3-6	71	0.65	1"	1"	3/8"	10	142	158	125	184	75	149	360	186	161	158	96	137	28	174	202
CM 3-7	80	0.84	1"	1"	3/8"	10	142	158	125	184	75	149	418	204	179	176	96	137	28	214	242
CM 3-8	80	1.20	1"	1"	3/8"	10	142	158	125	184	75	149	436	222	197	194	96	137	28	214	242

1 x 220-240 V, 50 Hz (supply voltage C)

Pump type	Frame size	P ₂ [kW]	Dimensions [mm]																		
			A1	A2	A3	A4	B1	B2	B3	H	H1	H2	L1	L2	L3	L4	L5	L6	L7	L8	L9
CM 3-2	71	0.30	1"	1"	3/8"	10	142	158	125	208	75	149	288	114	89	86	96	137	28	174	202
CM 3-3	71	0.50	1"	1"	3/8"	10	142	158	125	208	75	149	306	132	107	104	96	137	28	174	202
CM 3-4	71	0.50	1"	1"	3/8"	10	142	158	125	208	75	149	324	150	125	122	96	137	28	174	202
CM 3-5	71	0.50	1"	1"	3/8"	10	142	158	125	208	75	149	342	168	143	140	96	137	28	174	202
CM 3-6	80	0.67	1"	1"	3/8"	10	142	158	125	208	75	149	400	186	161	158	96	137	28	214	242
CM 3-7	80	0.90	1"	1"	3/8"	10	142	158	125	208	75	149	418	204	179	176	96	137	28	214	242
CM 3-8	80	0.90	1"	1"	3/8"	10	142	158	125	208	75	149	436	222	197	194	96	137	28	214	242

Dimensions, CM 50 Hz

CM 3-I and CM3-G
50 Hz

CM 3-I and CM 3-G

(I = EN 1.4301/AISI 304 and G = EN 1.4401/AISI 316)

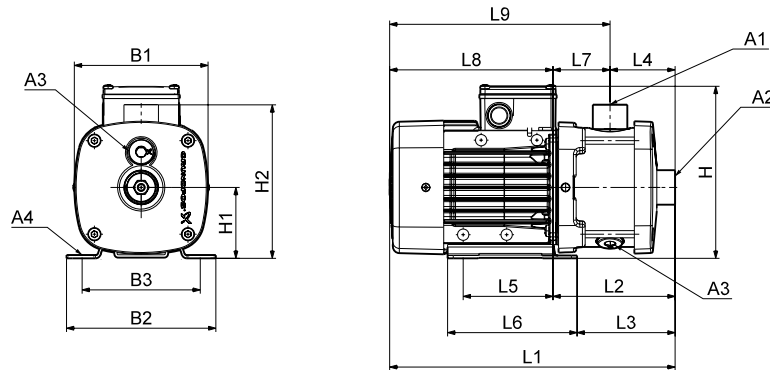

TM04 2246 2208

Dimensions

3 x 220-240 V / 380-415 V, 50 Hz (supply voltage F)

Pump type	Frame size	P ₂ [kW]	Dimensions [mm]																		
			A1	A2	A3	A4	B1	B2	B3	H	H1	H2	L1	L2	L3	L4	L5	L6	L7	L8	L9
CM 3-2	71	0.45	1"	1"	3/8"	10	142	158	125	184	75	165	305	131	107	72	96	137	60	174	234
CM 3-3	71	0.45	1"	1"	3/8"	10	142	158	125	184	75	165	305	131	107	72	96	137	60	174	234
CM 3-4	71	0.45	1"	1"	3/8"	10	142	158	125	184	75	165	323	149	125	90	96	137	60	174	234
CM 3-5	71	0.65	1"	1"	3/8"	10	142	158	125	184	75	165	341	167	143	108	96	137	60	174	234
CM 3-6	71	0.65	1"	1"	3/8"	10	142	158	125	184	75	165	377	203	179	144	96	137	60	174	234
CM 3-7	80	0.84	1"	1"	3/8"	10	142	158	125	184	75	165	417	203	179	144	96	137	60	214	274
CM 3-8	80	1.20	1"	1"	3/8"	10	142	158	125	184	75	165	453	239	215	180	96	137	60	214	274
CM 3-9*	80	1.20	1"	1"	3/8"	10	142	158	125	184	75	165	453	239	215	180	96	137	60	214	274
CM 3-10*	80	1.20	1"	1"	3/8"	10	142	158	125	184	75	165	489	275	251	216	96	137	60	214	274
CM 3-11*	90	1.58	1"	1"	3/8"	10	178	178	140	200	90	180	539	315	300	216	125	155	99	224	323
CM 3-12*	90	1.58	1"	1"	3/8"	10	178	178	140	200	90	180	593	369	354	270	125	155	99	224	323
CM 3-13*	90	1.58	1"	1"	3/8"	10	178	178	140	200	90	180	593	369	354	270	125	155	99	224	323
CM 3-14*	90	2.20	1"	1"	3/8"	10	178	178	140	200	90	180	593	369	354	270	125	155	99	224	323

* Only CM-G versions are available with this number of stages.

1 x 220-240 V, 50 Hz (supply voltage C)

Pump type	Frame size	P ₂ [kW]	Dimensions [mm]																		
			A1	A2	A3	A4	B1	B2	B3	H	H1	H2	L1	L2	L3	L4	L5	L6	L7	L8	L9
CM 3-2	71	0.30	1"	1"	3/8"	10	142	158	125	208	75	165	305	131	107	72	96	137	60	174	234
CM 3-3	71	0.50	1"	1"	3/8"	10	142	158	125	208	75	165	305	131	107	72	96	137	60	174	234
CM 3-4	71	0.50	1"	1"	3/8"	10	142	158	125	208	75	165	323	149	125	90	96	137	60	174	234
CM 3-5	71	0.50	1"	1"	3/8"	10	142	158	125	208	75	165	341	167	143	108	96	137	60	174	234
CM 3-6	80	0.67	1"	1"	3/8"	10	142	158	125	208	75	165	417	203	179	144	96	137	60	214	274
CM 3-7	80	0.90	1"	1"	3/8"	10	142	158	125	208	75	165	417	203	179	144	96	137	60	214	274
CM 3-8	80	0.90	1"	1"	3/8"	10	142	158	125	208	75	165	453	239	215	180	96	137	60	214	274
CM 3-9*	90	1.30	1"	1"	3/8"	10	178	178	140	229	90	180	503	279	264	180	125	155	99	224	323
CM 3-10*	90	1.30	1"	1"	3/8"	10	178	178	140	229	90	180	539	315	300	216	125	155	99	224	323
CM 3-11*	90	1.30	1"	1"	3/8"	10	178	178	140	229	90	180	539	315	300	216	125	155	99	224	323
CM 3-12*	90	1.30	1"	1"	3/8"	10	178	178	140	229	90	180	593	369	354	270	125	155	99	224	323
CM 3-13*	90	1.30	1"	1"	3/8"	10	178	178	140	229	90	180	593	369	354	270	125	155	99	224	323
CM 3-14*	90	1.70	1"	1"	3/8"	10	178	178	140	229	90	180	593	369	354	270	125	155	99	224	323

* Only CM-G versions are available with this number of stages.

Dimensions, CM 50 Hz

CM 5-A
50 Hz

CM 5-A

(A = cast iron, EN-GJL-200)

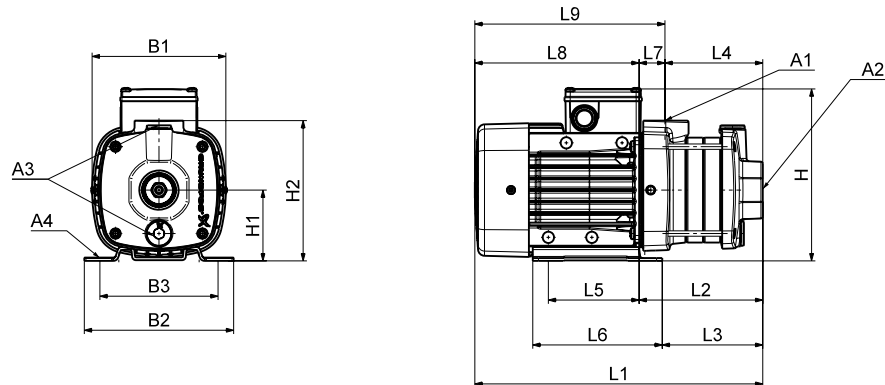

TM04 2248 2208

Dimensions

3 x 220-240 V / 380-415 V, 50 Hz (supply voltage F)

Pump type	Frame size	P ₂ [kW]	Dimensions [mm]																		
			A1	A2	A3	A4	B1	B2	B3	H	H1	H2	L1	L2	L3	L4	L5	L6	L7	L8	L9
CM 5-2	71	0.45	1"	1 1/4"	3/8"	10	142	158	125	184	75	149	288	114	89	86	96	137	28	174	202
CM 5-3	71	0.67	1"	1 1/4"	3/8"	10	142	158	125	184	75	149	306	132	107	104	96	137	28	174	202
CM 5-4	80	0.84	1"	1 1/4"	3/8"	10	142	158	125	184	75	149	364	150	125	122	96	137	28	214	242
CM 5-5	80	1.20	1"	1 1/4"	3/8"	10	142	158	125	184	75	149	382	168	143	140	96	137	28	214	242
CM 5-6	80	1.20	1"	1 1/4"	3/8"	10	142	158	125	184	75	149	400	186	161	158	96	137	28	214	242
CM 5-7	90	1.58	1"	1 1/4"	3/8"	10	178	178	140	200	90	201	469	245	230	163	125	155	82	224	306
CM 5-8	90	1.58	1"	1 1/4"	3/8"	10	178	178	140	200	90	201	487	263	248	181	125	155	82	224	306

1 x 220-240 V, 50 Hz (supply voltage C)

Pump type	Frame size	P ₂ [kW]	Dimensions [mm]																		
			A1	A2	A3	A4	B1	B2	B3	H	H1	H2	L1	L2	L3	L4	L5	L6	L7	L8	L9
CM 5-2	71	0.50	1"	1 1/4"	3/8"	10	142	158	125	208	75	149	288	114	89	86	96	137	28	174	202
CM 5-3	71	0.50	1"	1 1/4"	3/8"	10	142	158	125	208	75	149	306	132	107	104	96	137	28	174	202
CM 5-4	80	0.67	1"	1 1/4"	3/8"	10	142	158	125	208	75	149	364	150	125	122	96	137	28	214	242
CM 5-5	80	0.90	1"	1 1/4"	3/8"	10	142	158	125	208	75	149	382	168	143	140	125	137	28	214	242
CM 5-6	90	1.28	1"	1 1/4"	3/8"	10	178	178	140	229	90	201	451	227	212	145	125	155	82	224	306
CM 5-7	90	1.28	1"	1 1/4"	3/8"	10	178	178	140	229	90	201	469	245	230	163	125	155	82	224	306
CM 5-8	90	1.28	1"	1 1/4"	3/8"	10	178	178	140	229	90	201	487	263	248	181	125	155	82	224	306

Dimensions, CM 50 Hz

CM 5-I and CM 5-G
50 Hz

CM 5-I and CM 5-G

(I = EN 1.4301/AISI 304 and G = EN 1.4401/AISI 316)

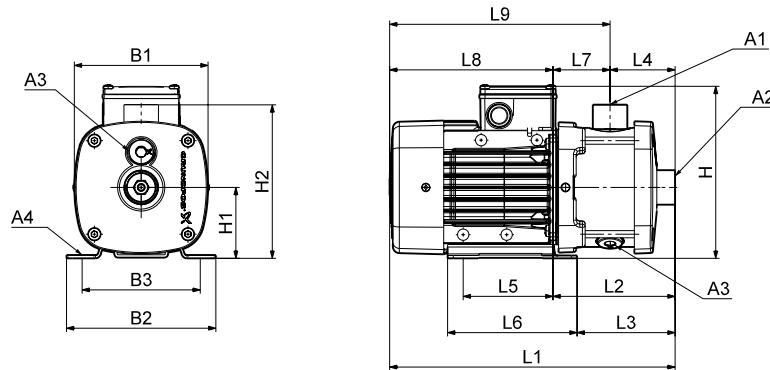

TM04 2246 2208

Dimensions

3 x 220-240 V / 380-415 V, 50 Hz (supply voltage F)

Pump type	Frame size	P ₂ [kW]	Dimensions [mm]																		
			A1	A2	A3	A4	B1	B2	B3	H	H1	H2	L1	L2	L3	L4	L5	L6	L7	L8	L9
CM 5-2	71	0.45	1"	1 1/4"	3/8"	10	142	158	125	184	75	165	305	131	107	72	96	137	60	174	234
CM 5-3	71	0.67	1"	1 1/4"	3/8"	10	142	158	125	184	75	165	305	131	107	72	96	137	60	174	234
CM 5-4	80	0.84	1"	1 1/4"	3/8"	10	142	158	125	184	75	165	363	149	125	90	96	137	60	214	274
CM 5-5	80	1.20	1"	1 1/4"	3/8"	10	142	158	125	184	75	165	381	167	143	108	96	137	60	214	274
CM 5-6	80	1.20	1"	1 1/4"	3/8"	10	142	158	125	184	75	165	417	203	179	144	96	137	60	214	274
CM 5-7	90	1.58	1"	1 1/4"	3/8"	10	178	178	140	200	90	180	467	243	228	144	125	155	99	224	323
CM 5-8	90	1.58	1"	1 1/4"	3/8"	10	178	178	140	200	90	180	503	279	264	180	125	155	99	224	323
CM 5-9*	90	2.20	1"	1 1/4"	3/8"	10	178	178	140	200	90	180	503	279	264	180	125	155	99	224	323
CM 5-10*	90	2.20	1"	1 1/4"	3/8"	10	178	178	140	200	90	180	539	315	300	216	125	155	99	224	323
CM 5-11*	90	2.20	1"	1 1/4"	3/8"	10	178	178	140	200	90	180	539	315	300	216	125	155	99	224	323
CM 5-12*	100	3.20	1"	1 1/4"	3/8"	10	178	178	140	200	90	180	593	369	354	270	125	155	99	224	323
CM 5-13*	100	3.20	1"	1 1/4"	3/8"	10	198	199	160	220	100	190	651	379	364	270	140	170	109	272	381

* Only CM-G versions are available with this number of stages

1 x 220-240 V, 50 Hz (supply voltage C)

Pump type	Frame size	P ₂ [kW]	Dimensions [mm]																		
			A1	A2	A3	A4	B1	B2	B3	H	H1	H2	L1	L2	L3	L4	L5	L6	L7	L8	L9
CM 5-2	71	0.50	1"	1 1/4"	3/8"	10	142	158	125	208	75	165	305	131	107	72	96	137	60	174	234
CM 5-3	71	0.50	1"	1 1/4"	3/8"	10	142	158	125	208	75	165	305	131	107	72	96	137	60	174	234
CM 5-4	80	0.67	1"	1 1/4"	3/8"	10	142	158	125	208	75	165	363	149	125	90	96	137	60	214	274
CM 5-5	80	0.90	1"	1 1/4"	3/8"	10	142	158	125	208	75	165	381	167	143	108	96	137	60	214	274
CM 5-6	90	1.28	1"	1 1/4"	3/8"	10	178	178	140	229	90	180	467	243	228	144	125	155	99	224	323
CM 5-7	90	1.28	1"	1 1/4"	3/8"	10	178	178	140	229	90	180	467	243	228	144	125	155	99	224	323
CM 5-8	90	1.28	1"	1 1/4"	3/8"	10	178	178	140	229	90	180	503	279	264	180	125	155	99	224	323
CM 5-9*	90	1.70	1"	1 1/4"	3/8"	10	178	178	140	229	90	180	503	279	264	180	125	155	99	224	323
CM 5-10*	90	1.70	1"	1 1/4"	3/8"	10	178	178	140	229	90	180	539	315	300	216	125	155	99	224	323
CM 5-11*	90	1.70	1"	1 1/4"	3/8"	10	178	178	140	229	90	180	539	315	300	216	125	155	99	224	323

* Only CM-G versions are available with this number of stages

Dimensions, CM 50 Hz

CM 10-A
50 Hz

CM 10-A

(A = cast iron, EN-GJL-200)

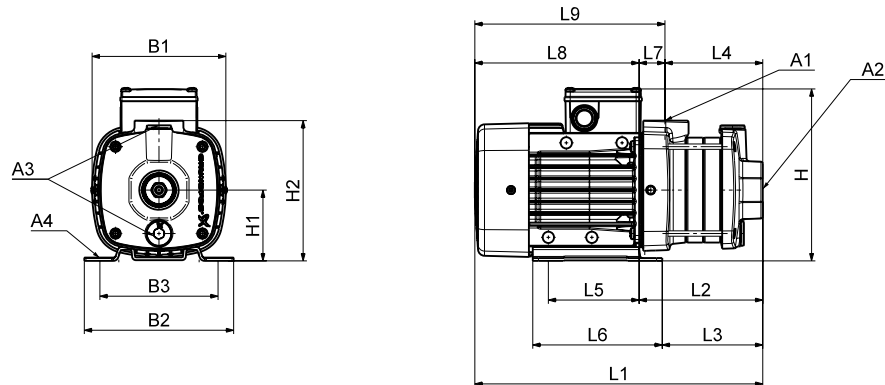

TM04 2248 2208

Dimensions

3 x 220-240 V / 380-415 V, 50 Hz (supply voltage F)

Pump type	Frame size	P ₂ [kW]	Dimensions [mm]																		
			A1	A2	A3	A4	B1	B2	B3	H	H1	H2	L1	L2	L3	L4	L5	L6	L7	L8	L9
CM 10-1	71	0.65	1 1/2"	1 1/2"	3/8"	10	190	158	125	209	100	245	329	155	131	97	96	137	58	174	232
CM 10-2	80	1.20	1 1/2"	1 1/2"	3/8"	10	190	158	125	209	100	245	369	155	131	97	96	137	58	214	272
CM 10-3	90	2.20	1 1/2"	1 1/2"	3/8"	10	190	199	160	210	100	245	451	220	205	127	140	170	93	232	324
CM 10-4	100	3.20	1 1/2"	1 1/2"	3/8"	10	198	199	160	220	100	245	537	265	250	157	140	170	108	272	380
CM 10-5	100	3.20	1 1/2"	1 1/2"	3/8"	10	198	199	160	220	100	245	567	295	280	187	140	170	108	272	380

1 x 220-240 V, 50 Hz (supply voltage C)

Pump type	Frame size	P ₂ [kW]	Dimensions [mm]																		
			A1	A2	A3	A4	B1	B2	B3	H	H1	H2	L1	L2	L3	L4	L5	L6	L7	L8	L9
CM 10-1	80	0.67	1 1/2"	1 1/2"	3/8"	10	190	158	125	233	100	245	369	155	131	97	96	137	58	214	272
CM 10-2	90	1.28	1 1/2"	1 1/2"	3/8"	10	190	199	160	239	100	245	421	190	175	97	140	170	93	232	324
CM 10-3	90	1.70	1 1/2"	1 1/2"	3/8"	10	190	199	160	239	100	245	451	220	205	127	140	170	93	232	324

Dimensions, CM 50 Hz

CM 10-I and CM 10-G
50 Hz

CM 10-I and CM 10-G

(I = EN 1.4301/AISI 304 and G = EN 1.4401/AISI 316)

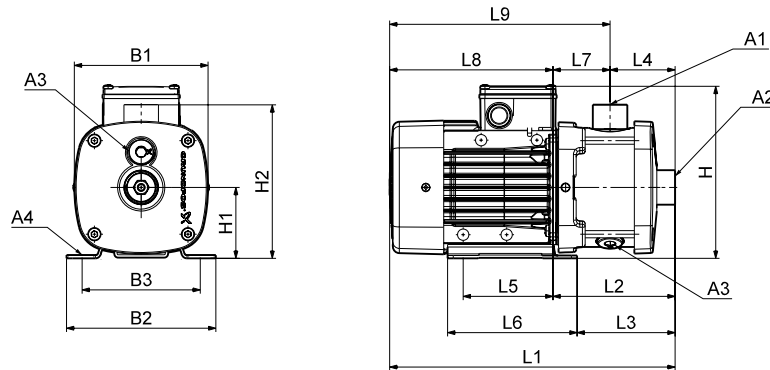

TM04 2246 2208

Dimensions

3 x 220-240 V / 380-415 V, 50 Hz (supply voltage F)

Pump type	Frame size	P ₂ [kW]	Dimensions [mm]																		
			A1	A2	A3	A4	B1	B2	B3	H	H1	H2	L1	L2	L3	L4	L5	L6	L7	L8	L9
CM 10-1	71	0.65	1 1/2"	1 1/2"	3/8"	10	180	158	125	209	100	218	359	185	161	105	96	137	80	174	254
CM 10-2	80	1.20	1 1/2"	1 1/2"	3/8"	10	180	158	125	209	100	218	399	185	161	105	96	137	80	214	294
CM 10-3	90	2.20	1 1/2"	1 1/2"	3/8"	10	180	199	160	210	100	218	450	219	204	105	140	170	114	232	345
CM 10-4	100	3.20	1 1/2"	1 1/2"	3/8"	10	198	199	160	220	100	218	537	265	250	135	140	170	130	272	402
CM 10-5	100	3.20	1 1/2"	1 1/2"	3/8"	10	198	199	160	220	100	218	597	325	310	195	140	170	130	272	402
CM 10-6	100	4.00	1 1/2"	1 1/2"	3/8"	10	198	199	160	220	100	218	597	325	310	195	140	170	130	272	402
CM 10-7	112	5.80	1 1/2"	1 1/2"	3/8"	12	220	228	190	246	112	230	709	407	391	255	140	172	152	302	454
CM 10-8	112	5.80	1 1/2"	1 1/2"	3/8"	12	220	228	190	246	112	230	709	407	391	255	140	172	152	302	454

1 x 220-240 V, 50 Hz (supply voltage C)

Pump type	Frame size	P ₂ [kW]	Dimensions [mm]																		
			A1	A2	A3	A4	B1	B2	B3	H	H1	H2	L1	L2	L3	L4	L5	L6	L7	L8	L9
CM 10-1	80	0.67	1 1/2"	1 1/2"	3/8"	10	180	158	125	233	100	218	399	185	161	105	96	137	80	214	294
CM 10-2	90	1.28	1 1/2"	1 1/2"	3/8"	10	180	199	160	239	100	218	450	219	204	105	140	170	114	232	345
CM 10-3	90	1.70	1 1/2"	1 1/2"	3/8"	10	180	199	160	239	100	218	450	219	204	105	140	170	114	232	345

Dimensions, CM 50 Hz

CM 15-A
50 Hz

CM 15-A

(A = cast iron, EN-GJL-200)

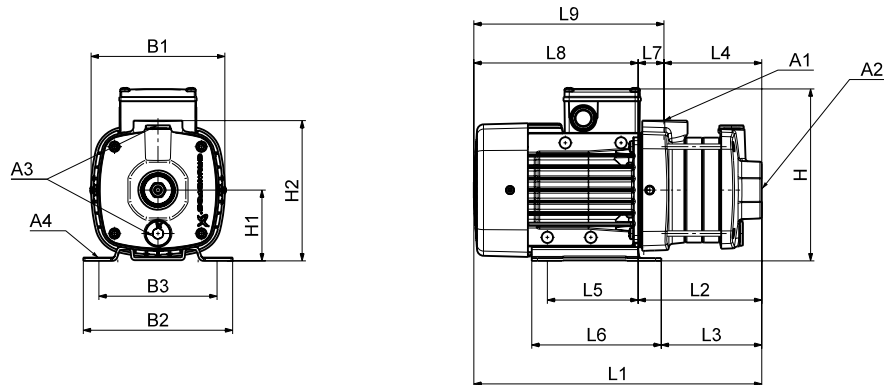

TM04 2248 2208

Dimensions

3 x 220-240 V / 380-415 V, 50 Hz (supply voltage F)

Pump type	Frame size	P ₂ [kW]	Dimensions [mm]																		
			A1	A2	A3	A4	B1	B2	B3	H	H1	H2	L1	L2	L3	L4	L5	L6	L7	L8	L9
CM 15-1	80	1.20	2"	2"	3/8"	10	190	158	125	209	100	245	369	155	131	97	96	137	58	214	272
CM 15-2	90	2.20	2"	2"	3/8"	10	190	199	160	210	100	245	421	190	175	97	140	170	93	232	324
CM 15-3	100	4.00	2"	2"	3/8"	10	198	199	160	220	100	245	507	235	220	127	140	170	108	272	380
CM 15-4	112	5.80	2"	2"	3/8"	12	220	228	190	246	112	257	590	288	272	157	140	172	131	302	433

1 x 220-240 V, 50 Hz (supply voltage C)

Pump type	Frame size	P ₂ [kW]	Dimensions [mm]																		
			A1	A2	A3	A4	B1	B2	B3	H	H1	H2	L1	L2	L3	L4	L5	L6	L7	L8	L9
CM 15-1	90	1.28	2"	2"	3/8"	10	190	199	160	239	100	245	421	190	175	97	140	170	93	232	324
CM 15-2	90	1.70	2"	2"	3/8"	10	190	199	160	239	100	245	421	190	175	97	140	170	93	232	324

Dimensions, CM 50 Hz

CM 15-I and CM 15-G
50 Hz

CM 15-I and CM 15-G

(I = EN 1.4301/AISI 304 and G = EN 1.4401/AISI 316)

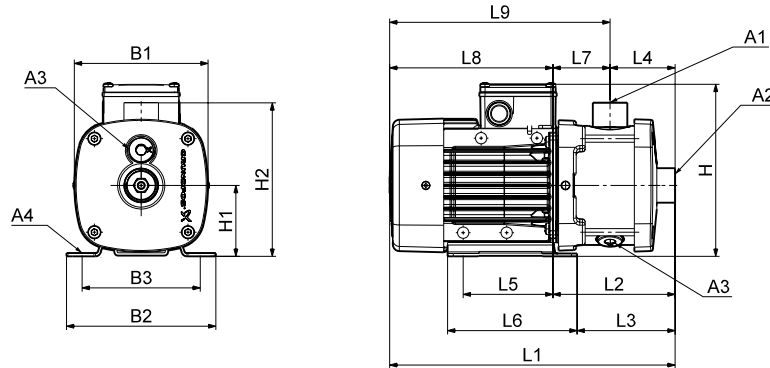

TM04 2246 2208

Dimensions

3 x 220-240 V / 380-415 V, 50 Hz (supply voltage F)

Pump type	Frame size	P ₂ [kW]	Dimensions [mm]																		
			A1	A2	A3	A4	B1	B2	B3	H	H1	H2	L1	L2	L3	L4	L5	L6	L7	L8	L9
CM 15-1	80	1.20	2"	2"	3/8"	10	180	158	125	209	100	218	399	185	161	105	96	137	80	214	294
CM 15-2	90	2.20	2"	2"	3/8"	10	180	199	160	210	100	218	450	219	204	105	140	170	114	232	345
CM 15-3	100	4.00	2"	2"	3/8"	10	198	199	160	220	100	218	507	235	220	105	140	170	130	272	402
CM 15-4	112	5.80	2"	2"	3/8"	12	220	228	190	246	112	230	589	287	271	135	140	172	152	302	454

1 x 220-240 V, 50 Hz (supply voltage C)

Pump type	Frame size	P ₂ [kW]	Dimensions [mm]																		
			A1	A2	A3	A4	B1	B2	B3	H	H1	H2	L1	L2	L3	L4	L5	L6	L7	L8	L9
CM 15-1	90	1.28	2"	2"	3/8"	10	180	199	160	239	100	218	450	219	204	105	140	170	114	232	345
CM 15-2	90	1.70	2"	2"	3/8"	10	180	199	160	239	100	218	450	219	204	105	140	170	114	232	345

Dimensions, CM 50 Hz

CM 25-A
50 Hz

CM 25-A

(A = cast iron, EN-GJL-200)

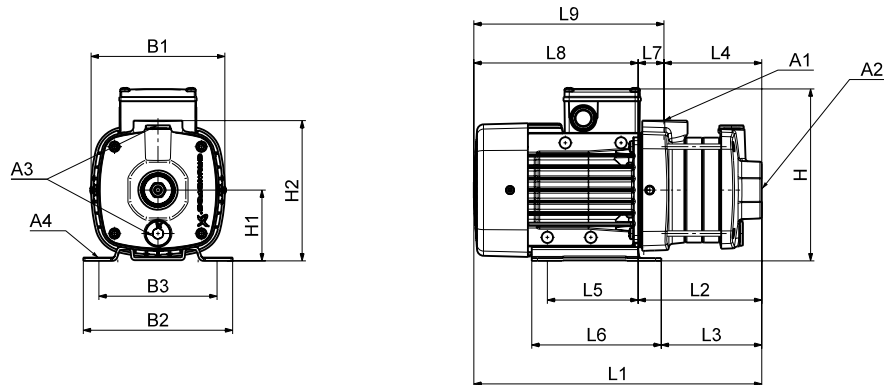

TM04 2248 2208

Dimensions

3 x 220-240 V / 380-415 V, 50 Hz (supply voltage F)

Pump type	Frame size	P ₂ [kW]	Dimensions [mm]																		
			A1	A2	A3	A4	B1	B2	B3	H	H1	H2	L1	L2	L3	L4	L5	L6	L7	L8	L9
CM 25-1	90	2.20	2"	2"	3/8"	10	190	199	160	210	100	245	421	190	175	97	140	170	93	232	324
CM 25-2	100	4.00	2"	2"	3/8"	10	198	199	160	220	100	245	477	205	190	97	140	170	108	272	380
CM 25-3	112	5.80	2"	2"	3/8"	12	220	228	190	246	112	257	560	258	242	127	140	172	131	302	433
CM 25-4	132	7.40	2"	2"	3/8"	12	220	228	190	246	112	257	590	288	272	157	140	172	131	302	433

1 x 220-240 V, 50 Hz (supply voltage C)

Pump type	Frame size	P ₂ [kW]	Dimensions [mm]																		
			A1	A2	A3	A4	B1	B2	B3	H	H1	H2	L1	L2	L3	L4	L5	L6	L7	L8	L9
CM 25-1	90	1.70	2"	2"	3/8"	10	190	199	160	239	100	245	421	190	175	97	140	170	93	232	324

Dimensions, CM 50 Hz

CM 25-I and CM 25-G
50 Hz

CM 25-I and CM 25-G

(I = EN 1.4301/AISI 304 and G = EN 1.4401/AISI 316)

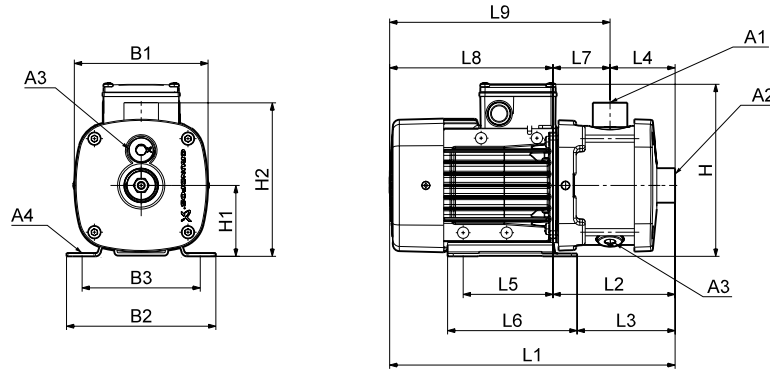

TM04 2246 2208

Dimensions

3 x 220-240 V / 380-415 V, 50 Hz (supply voltage F)

Pump type	Frame size	P ₂ [kW]	Dimensions [mm]																		
			A1	A2	A3	A4	B1	B2	B3	H	H1	H2	L1	L2	L3	L4	L5	L6	L7	L8	L9
CM 25-1	90	2.20	2"	2"	3/8"	10	180	199	160	210	100	218	450	219	204	105	140	170	114	232	345
CM 25-2	100	4.00	2"	2"	3/8"	10	198	199	160	220	100	218	507	235	220	105	140	170	130	272	402
CM 25-3	112	5.80	2"	2"	3/8"	12	220	228	190	246	112	230	559	257	241	105	140	172	152	302	454
CM 25-4	132	7.40	2"	2"	3/8"	12	220	228	190	246	112	230	589	287	271	135	140	172	152	302	454

1 x 220-240 V, 50 Hz (supply voltage C)

Pump type	Frame size	P ₂ [kW]	Dimensions [mm]																		
			A1	A2	A3	A4	B1	B2	B3	H	H1	H2	L1	L2	L3	L4	L5	L6	L7	L8	L9
CM 25-1	90	1.70	2"	2"	3/8"	10	180	199	160	239	100	218	450	219	204	105	140	170	114	232	345

Dimensions, CM 60 Hz and 50/60 Hz

CM 1-A
60 Hz
50/60 Hz

CM 1-A

(A = cast iron, EN-GJL-200)

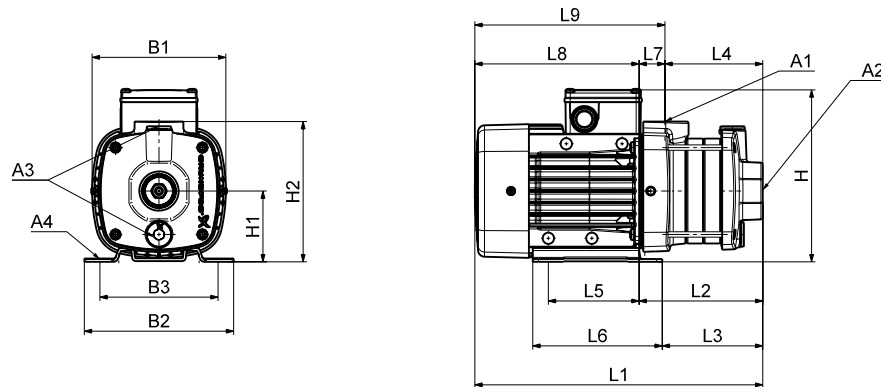

TM04 2248 2208

Dimensions

3 x 208-230 V / 440-480 V, 60 Hz (supply voltage E)

3 x 575 V, 60 Hz (supply voltage H)

3 x 400 V, 50/60 Hz (supply voltage I)

3 x 380-415 V, 50 Hz; 3 x 440-480 V, 60 Hz (supply voltage J)

3 x 220-240/380-415 V, 50 Hz; 3 x 220-255/380-440 V, 60 Hz (supply voltage O)

Pump type	Frame size	P ₂ [kW]		Dimensions [mm]																		
		50 Hz	60 Hz	A1	A2	A3	A4	B1	B2	B3	H	H1	H2	L1	L2	L3	L4	L5	L6	L7	L8	L9
CM 1-2	71	0.25/0.43*	0.43/0.74*	1"	1"	3/8"	10	142	158	125	191	75	149	288	114	89	86	96	137	28	174	202
CM 1-3	71	0.25/0.43*	0.43/0.74*	1"	1"	3/8"	10	142	158	125	191	75	149	306	132	107	104	96	137	28	174	202
CM 1-4	71	0.43	0.74	1"	1"	3/8"	10	142	158	125	191	75	149	324	150	125	122	96	137	28	174	202
CM 1-5	71	0.43	0.74	1"	1"	3/8"	10	142	158	125	191	75	149	342	168	143	140	96	137	28	174	202

* Applies to supply voltage O.

1 x 115/230 V, 60 Hz (supply voltage B)

1 x 220 V, 60 Hz (supply voltage A)

Pump type	Frame size	P ₂ [kW]	Dimensions [mm]																		
			A1	A2	A3	A4	B1	B2	B3	H	H1	H2	L1	L2	L3	L4	L5	L6	L7	L8	L9
CM 1-2	71	0.60	1"	1"	3/8"	10	142	158	125	208	75	149	288	114	89	86	96	137	28	174	202
CM 1-3	71	0.60	1"	1"	3/8"	10	142	158	125	208	75	149	306	132	107	104	96	137	28	174	202
CM 1-4	71	0.60	1"	1"	3/8"	10	142	158	125	208	75	149	324	150	125	122	96	137	28	174	202
CM 1-5	71	0.60	1"	1"	3/8"	10	142	158	125	208	75	149	342	168	143	140	96	137	28	174	202

3 x 200/346 V, 50 Hz; 3 x 200-220/346-380 V, 60 Hz (supply voltage G)

Pump type	Frame size	P ₂ [kW]		Dimensions [mm]																		
		50 Hz	60 Hz	A1	A2	A3	A4	B1	B2	B3	H	H1	H2	L1	L2	L3	L4	L5	L6	L7	L8	L9
CM 1-2	71	0.25	0.43	1"	1"	3/8"	10	142	158	125	184	75	149	288	114	89	86	96	137	28	174	202
CM 1-3	71	0.25	0.43	1"	1"	3/8"	10	142	158	125	184	75	149	306	132	107	104	96	137	28	174	202
CM 1-4	71	0.43	0.74	1"	1"	3/8"	10	142	158	125	184	75	149	324	150	125	122	96	137	28	174	202
CM 1-5	71	0.43	0.74	1"	1"	3/8"	10	142	158	125	184	75	149	342	168	143	140	96	137	28	174	202

Dimensions, CM 60 Hz and 50/60 Hz

CM 1-I and CM 1-G
60 Hz
50/60 Hz

CM 1-I and CM 1-G

(I = EN 1.4301/AISI 304 and G = EN 1.4401/AISI 316)

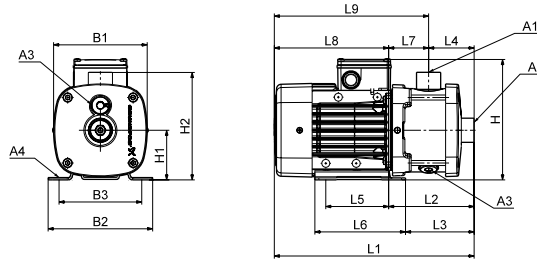

TM04 2246 2208

Dimensions

3 x 208-230 V / 440-480 V, 60 Hz (supply voltage E)

3 x 575 V, 60 Hz (supply voltage H)

3 x 400 V, 50/60 Hz (supply voltage I)

3 x 380-415 V, 50 Hz; 3 x 440-480 V, 60 Hz (supply voltage J)

3 x 220-240/380-415 V, 50 Hz; 3 x 220-255/380-440 V, 60 Hz (supply voltage O)

Pump type	Frame size	P ₂ [kW]		Dimensions [mm]																		
		50 Hz	60 Hz	A1	A2	A3	A4	B1	B2	B3	H	H1	H2	L1	L2	L3	L4	L5	L6	L7	L8	L9
CM 1-2	71	0.25/0.43**	0.43/0.74**	1"	1"	3/8"	10	142	158	125	191	75	165	305	131	107	72	96	137	60	174	234
CM 1-3	71	0.25/0.43**	0.43/0.74**	1"	1"	3/8"	10	142	158	125	191	75	165	305	131	107	72	96	137	60	174	234
CM 1-4	71	0.43	0.74	1"	1"	3/8"	10	142	158	125	191	75	165	323	149	125	90	96	137	60	174	234
CM 1-5	71	0.43	0.74	1"	1"	3/8"	10	142	158	125	191	75	165	341	167	143	108	96	137	60	174	234
CM 1-6*	71	0.43	0.74	1"	1"	3/8"	10	142	158	125	191	75	165	377	203	179	144	96	137	60	174	234
CM 1-7*	71	0.43	0.74	1"	1"	3/8"	10	142	158	125	191	75	165	377	203	179	144	96	137	60	174	234
CM 1-8*	80	0.60	1.04	1"	1"	3/8"	10	142	158	125	191	75	165	453	239	215	180	96	137	60	214	274
CM 1-9*	80	0.74	1.28	1"	1"	3/8"	10	142	158	125	191	75	165	453	239	215	180	96	137	60	214	274

* Only CM-G versions are available with this number of stages.

** Applies to supply voltage O.

1 x 115/230 V, 60 Hz (supply voltage B)

1 x 220 V, 60 Hz (supply voltage A)

Pump type	Frame size	P ₂ [kW]	Dimensions [mm]																		
			A1	A2	A3	A4	B1	B2	B3	H	H1	H2	L1	L2	L3	L4	L5	L6	L7	L8	L9
CM 1-2	71	0.60	1"	1"	3/8"	10	142	158	125	208	75	165	305	131	107	72	96	137	60	174	234
CM 1-3	71	0.60	1"	1"	3/8"	10	142	158	125	208	75	165	305	131	107	72	96	137	60	174	234
CM 1-4	71	0.60	1"	1"	3/8"	10	142	158	125	208	75	165	323	149	125	90	96	137	60	174	234
CM 1-5	71	0.60	1"	1"	3/8"	10	142	158	125	208	75	165	341	167	143	108	96	137	60	174	234
CM 1-6*	80	0.78**/0.84	1"	1"	3/8"	10	142	158	125	208	75	165	417	203	179	144	96	137	60	214	274
CM 1-7*	80	1.10**/1.14	1"	1"	3/8"	10	205	158	125	208	75	165	417	203	179	144	96	137	60	214	274
CM 1-8*	80	1.10**/1.14	1"	1"	3/8"	10	205	158	125	208	75	165	453	239	215	180	96	137	60	214	274
CM 1-9*	80	1.10**/1.14	1"	1"	3/8"	10	205	158	125	208	75	165	453	239	215	180	96	137	60	214	274

* Only CM-G versions are available with this number of stages.

** Applies to supply voltage B.

3 x 200/346 V, 50 Hz; 3 x 200-220/346-380 V, 60 Hz (supply voltage G)

Pump type	Frame size	P ₂ [kW]		Dimensions [mm]																		
		50 Hz	60 Hz	A1	A2	A3	A4	B1	B2	B3	H	H1	H2	L1	L2	L3	L4	L5	L6	L7	L8	L9
CM 1-2	71	0.25	0.43	1"	1"	3/8"	10	142	158	125	184	75	165	305	131	107	72	96	137	60	174	234
CM 1-3	71	0.25	0.43	1"	1"	3/8"	10	142	158	125	184	75	165	305	131	107	72	96	137	60	174	234
CM 1-4	71	0.43	0.74	1"	1"	3/8"	10	142	158	125	184	75	165	323	149	125	90	96	137	60	174	234
CM 1-5	71	0.43	0.74	1"	1"	3/8"	10	142	158	125	184	75	165	341	167	143	108	96	137	60	174	234
CM 1-6	71	0.43	0.74	1"	1"	3/8"	10	142	158	125	184	75	165	377	203	179	144	96	137	60	174	234
CM 1-7	71	0.43	0.74	1"	1"	3/8"	10	142	158	125	184	75	165	377	203	179	144	96	137	60	174	234
CM 1-8	80	0.60	1.04	1"	1"	3/8"	10	142	158	125	184	75	165	453	239	215	180	96	137	60	214	274
CM 1-9	80	0.74	1.28	1"	1"	3/8"	10	142	158	125	184	75	165	453	239	215	180	96	137	60	214	274

Dimensions, CM 60 Hz and 50/60 Hz

CM 3-A
60 Hz
50/60 Hz

CM 3-A

(A = cast iron, EN-GJL-200)

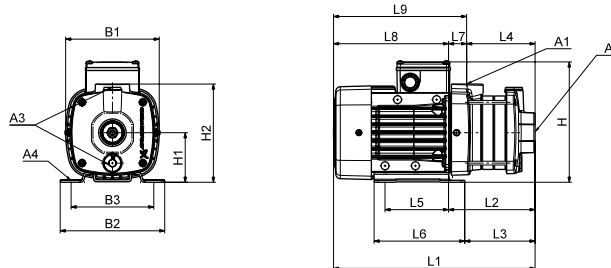

TM04 2248 2208

Dimensions

3 x 208-230 V / 440-480 V, 60 Hz (supply voltage E)

3 x 575 V, 60 Hz (supply voltage H)

3 x 400 V, 50/60 Hz (supply voltage I)

3 x 380-415 V, 50 Hz; 3 x 440-480 V, 60 Hz (supply voltage J)

3 x 220-240/380-415 V, 50 Hz; 3 x 220-255/380-440 V, 60 Hz (supply voltage O)

Pump type	Frame size	P ₂ [kW]		Dimensions [mm]																		
		50 Hz	60 Hz	A1	A2	A3	A4	B1	B2	B3	H	H1	H2	L1	L2	L3	L4	L5	L6	L7	L8	L9
CM 3-2	71	0.25*/0.43	0.43*/0.74	1"	1"	3/8"	10	142	158	125	191	75	149	288	114	89	86	96	137	28	174	202
CM 3-3	71	0.43	0.74	1"	1"	3/8"	10	142	158	125	191	75	149	306	132	107	104	96	137	28	174	202
CM 3-4	71	0.43	0.74	1"	1"	3/8"	10	142	158	125	191	75	149	324	150	125	122	96	137	28	174	202
CM 3-5	80	0.60	1.04	1"	1"	3/8"	10	142	158	125	191	75	149	382	168	143	140	96	137	28	214	242

* Applies to voltage type I.

1 x 115/230 V, 60 Hz (supply voltage B)

1 x 220 V, 60 Hz (supply voltage A)

Pump type	Frame size	P ₂ [kW]	Dimensions [mm]																		
			A1	A2	A3	A4	B1	B2	B3	H	H1	H2	L1	L2	L3	L4	L5	L6	L7	L8	L9
CM 3-2	71	0.60	1"	1"	3/8"	10	142	158	125	208	75	149	288	114	89	86	96	137	28	174	202
CM 3-3	71	0.60	1"	1"	3/8"	10	142	158	125	208	75	149	306	132	107	104	96	137	28	174	202
CM 3-4	80	0.78*/0.84	1"	1"	3/8"	10	142	158	125	208	75	149	364	150	125	122	96	137	28	214	242
CM 3-5	80	1.10*/1.14	1"	1"	3/8"	10	205	158	125	208	75	149	382	168	143	140	96	137	28	214	242

* Applies to voltage type B.

3 x 200/346 V, 50 Hz; 3 x 200-220/346-380 V, 60 Hz (supply voltage G)

Pump type	Frame size	P ₂ [kW]		Dimensions [mm]																		
		50 Hz	60 Hz	A1	A2	A3	A4	B1	B2	B3	H	H1	H2	L1	L2	L3	L4	L5	L6	L7	L8	L9
CM 3-2	71	0.25	0.43	1"	1"	3/8"	10	142	158	125	184	75	149	288	114	89	86	96	137	28	174	202
CM 3-3	71	0.43	0.74	1"	1"	3/8"	10	142	158	125	184	75	149	306	132	107	104	96	137	28	174	202
CM 3-4	71	0.43	0.74	1"	1"	3/8"	10	142	158	125	184	75	149	324	150	125	122	96	137	28	174	202
CM 3-5	80	0.60	1.04	1"	1"	3/8"	10	142	158	125	184	75	149	382	168	143	140	96	137	28	214	242

Dimensions, CM 60 Hz and 50/60 Hz

CM 3-I and CM 3-G
60 Hz
50/60 Hz

CM 3-I and CM 3-G

(I = EN 1.4301/AISI 304 and G = EN 1.4401/AISI 316)

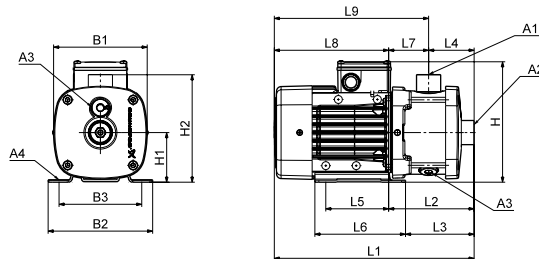

TM04 2246 2208

Dimensions

3 x 208-230 V / 440-480 V, 60 Hz (supply voltage E)

3 x 575 V, 60 Hz (supply voltage H)

3 x 400 V, 50/60 Hz (supply voltage I)

3 x 380-415 V, 50 Hz; 3 x 440-480 V, 60 Hz (supply voltage J)

3 x 220-240/380-415 V, 50 Hz; 3 x 220-255/380-440 V, 60 Hz (supply voltage O)

Pump type	Frame size	P ₂ [kW]		Dimensions [mm]																		
		50 Hz	60 Hz	A1	A2	A3	A4	B1	B2	B3	H	H1	H2	L1	L2	L3	L4	L5	L6	L7	L8	L9
CM 3-2	71	0.25/0.43**	0.43/0.74**	1"	1"	3/8"	10	142	158	125	191	75	165	305	131	107	72	96	137	60	174	234
CM 3-3	71	0.43	0.74	1"	1"	3/8"	10	142	158	125	191	75	165	305	131	107	72	96	137	60	174	234
CM 3-4	71	0.43	0.74	1"	1"	3/8"	10	142	158	125	191	75	165	323	149	125	90	96	137	60	174	234
CM 3-5	80	0.60	1.04	1"	1"	3/8"	10	142	158	125	191	75	165	381	167	143	108	96	137	60	214	274
CM 3-6*	80	0.74	1.28	1"	1"	3/8"	10	142	158	125	191	75	165	417	203	179	144	96	137	60	214	274
CM 3-7*	90	0.87/1.00***	1.70	1"	1"	3/8"	10	178	178	140	200	90	180	467	243	228	144	125	155	99	224	323
CM 3-8*	90	1.45	2.52	1"	1"	3/8"	10	178	178	140	200	90	180	503	279	264	180	125	155	99	224	323
CM 3-9*	90	1.45	2.52	1"	1"	3/8"	10	178	178	140	200	90	180	503	279	264	180	125	155	99	224	323

* Only CM-G versions are available with this number of stages.

** Applies to supply voltage O.

*** Applies to supply voltage J.

1 x 115/230 V, 60 Hz (supply voltage B)

1 x 220 V, 60 Hz (supply voltage A)

Pump type	Frame size	P ₂ [kW]	Dimensions [mm]																		
			A1	A2	A3	A4	B1	B2	B3	H	H1	H2	L1	L2	L3	L4	L5	L6	L7	L8	L9
CM 3-2	71	0.60	1"	1"	3/8"	10	142	158	125	208	75	165	305	131	107	72	96	137	60	174	234
CM 3-3	71	0.60	1"	1"	3/8"	10	142	158	125	208	75	165	305	131	107	72	96	137	60	174	234
CM 3-4	80	0.78**/0.84	1"	1"	3/8"	10	142	158	125	208	75	165	363	149	125	90	96	137	60	214	274
CM 3-5	80	1.10**/1.14	1"	1"	3/8"	10	205	158	125	208	75	165	381	167	143	108	96	137	60	214	274
CM 3-6*	90	1.50**/1.54	1"	1"	3/8"	10	178	178	140	229	90	180	467	243	228	144	125	155	99	224	323
CM 3-7*	90	1.50**/1.54	1"	1"	3/8"	10	178	178	140	229	90	180	467	243	228	144	125	155	99	224	323
CM 3-8*	90	1.50**/1.54	1"	1"	3/8"	10	178	178	140	229	90	180	503	279	264	180	125	155	99	224	323

* Only CM-G versions are available with this number of stages.

** Applies to supply voltage B.

3 x 200/346 V, 50 Hz; 3 x 200-220/346-380 V, 60 Hz (supply voltage G)

Pump type	Frame size	P ₂ [kW]		Dimensions [mm]																		
		50 Hz	60 Hz	A1	A2	A3	A4	B1	B2	B3	H	H1	H2	L1	L2	L3	L4	L5	L6	L7	L8	L9
CM 3-2	71	0.25	0.43	1"	1"	3/8"	10	142	158	125	184	75	165	305	131	107	72	96	137	60	174	234
CM 3-3	71	0.43	0.74	1"	1"	3/8"	10	142	158	125	184	75	165	305	131	107	72	96	137	60	174	234
CM 3-4	71	0.43	0.74	1"	1"	3/8"	10	142	158	125	184	75	165	323	149	125	90	96	137	60	174	234
CM 3-5	80	0.60	1.04	1"	1"	3/8"	10	142	158	125	184	75	165	381	167	143	108	96	137	60	214	274
CM 3-6	80	0.74	1.28	1"	1"	3/8"	10	142	158	125	184	75	165	417	203	179	144	96	137	60	214	274
CM 3-7	90	0.87	1.70	1"	1"	3/8"	10	178	178	140	200	90	180	467	243	228	144	125	155	99	224	323
CM 3-8	90	1.40	2.50	1"	1"	3/8"	10	178	178	140	200	90	180	503	279	264	180	125	155	99	224	323
CM 3-9	90	1.40	2.50	1"	1"	3/8"	10	178	178	140	200	90	180	503	279	264	180	125	155	99	224	323

Dimensions, CM 60 Hz and 50/60 Hz

CM 5-A
60 Hz
50/60 Hz

CM 5-A

(A = cast iron, EN-GJL-200)

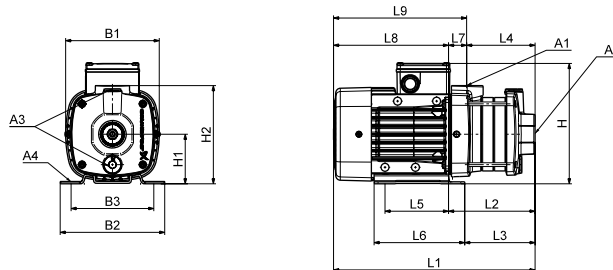

TM04 2248 2208

Dimensions

3 x 208-230 V / 440-480 V, 60 Hz (supply voltage E)

3 x 575 V, 60 Hz (supply voltage H)

3 x 400 V, 50/60 Hz (supply voltage I)

3 x 380-415 V, 50 Hz; 3 x 440-480 V, 60 Hz (supply voltage J)

3 x 220-240/380-415 V, 50 Hz; 3 x 220-255/380-440 V, 60 Hz (supply voltage O)

Pump type	Frame size	P ₂ [kW]		Dimensions [mm]																		
		50 Hz	60 Hz	A1	A2	A3	A4	B1	B2	B3	H	H1	H2	L1	L2	L3	L4	L5	L6	L7	L8	L9
CM 5-2	71	0.25/0.43*	0.43/0.74*	1"	1 1/4"	3/8"	10	142	158	125	191	75	149	288	114	89	86	96	137	28	174	202
CM 5-3	80	0.60	1.04	1"	1 1/4"	3/8"	10	142	158	125	191	75	149	346	132	107	104	96	137	28	214	242
CM 5-4	90	0.87/1.00**	1.70	1"	1 1/4"	3/8"	10	178	178	140	200	90	201	415	191	176	109	125	155	82	224	306
CM 5-5	90	1.45	2.52	1"	1 1/4"	3/8"	10	178	178	140	200	90	201	433	209	194	127	125	155	82	224	306

* Applies to supply voltage O.

** Applies to supply voltage J.

1 x 115/230 V, 60 Hz (supply voltage B)

1 x 220 V, 60 Hz (supply voltage A)

Pump type	Frame size	P ₂ [kW]		Dimensions [mm]																	
		50 Hz	60 Hz	A1	A2	A3	A4	B1	B2	B3	H	H1	H2	L1	L2	L3	L4	L5	L6	L7	L8
CM 5-2	80	0.78*/0.84	1"	1 1/4"	3/8"	10	142	158	125	208	75	149	328	114	89	86	96	137	28	214	242
CM 5-3	80	1.10*/1.14	1"	1 1/4"	3/8"	10	205	158	125	208	75	149	346	132	107	104	96	137	28	214	242
CM 5-4	90	1.50*/1.54	1"	1 1/4"	3/8"	10	178	178	140	208	90	201	415	191	176	109	125	155	82	224	306

* Applies to supply voltage B.

3 x 200/346 V, 50 Hz; 3 x 200-220/346-380 V, 60 Hz (supply voltage G)

Pump type	Frame size	P ₂ [kW]		Dimensions [mm]																		
		50 Hz	60 Hz	A1	A2	A3	A4	B1	B2	B3	H	H1	H2	L1	L2	L3	L4	L5	L6	L7	L8	L9
CM 5-2	71	0.43	0.74	1"	1 1/4"	3/8"	10	142	158	125	184	75	149	288	114	89	86	96	137	28	174	202
CM 5-3	80	0.60	1.04	1"	1 1/4"	3/8"	10	142	158	125	184	75	149	346	132	107	104	96	137	28	214	242
CM 5-4	90	0.87	1.70	1"	1 1/4"	3/8"	10	178	178	140	200	90	201	415	191	176	109	125	155	82	224	306
CM 5-5	90	1.40	2.50	1"	1 1/4"	3/8"	10	178	178	140	200	90	201	433	209	194	127	125	155	82	224	306

Dimensions, CM 60 Hz and 50/60 Hz

CM 5-I and CM 5-G
60 Hz
50/60 Hz

CM 5-I and CM 5-G

(I = EN 1.4301/AISI 304 and G = EN 1.4401/AISI 316)

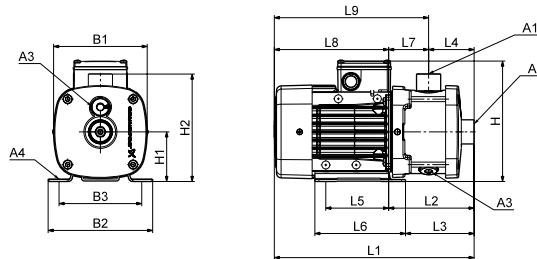

TM04 2246 2208

Dimensions

3 x 208-230 V / 440-480 V, 60 Hz (supply voltage E)

3 x 575 V, 60 Hz (supply voltage H)

3 x 400 V, 50/60 Hz (supply voltage I)

3 x 380-415 V, 50 Hz; 3 x 440-480 V, 60 Hz (supply voltage J)

3 x 220-240/380-415 V, 50 Hz; 3 x 220-255/380-440 V, 60 Hz (supply voltage O)

Pump type	Frame size	P ₂ [kW]		Dimensions [mm]																		
		50 Hz	60 Hz	A1	A2	A3	A4	B1	B2	B3	H	H1	H2	L1	L2	L3	L4	L5	L6	L7	L8	L9
CM 5-2	71	0.25/0.43**	0.43/0.74**	1"	1 1/4"	3/8"	10	142	158	125	191	75	165	305	131	107	72	96	137	60	174	234
CM 5-3	80	0.60	1.04	1"	1 1/4"	3/8"	10	142	158	125	191	75	165	345	131	107	72	96	137	60	214	274
CM 5-4	90	0.87/1.00***	1.70	1"	1 1/4"	3/8"	10	178	178	140	200	90	180	413	189	174	90	125	155	99	224	323
CM 5-5	90	1.45	2.52	1"	1 1/4"	3/8"	10	178	178	140	200	90	180	431	207	192	108	125	155	99	224	323
CM 5-6*	90	1.45	2.52	1"	1 1/4"	3/8"	10	178	178	140	200	90	180	467	243	228	144	125	155	99	224	323
CM 5-7*	90	1.45	2.52	1"	1 1/4"	3/8"	10	178	178	140	200	90	180	467	243	228	144	125	155	99	224	323
CM 5-8*	100	2.30	4.00	1"	1 1/4"	3/8"	10	198	199	160	220	100	190	561	289	274	180	140	170	109	272	381

* Only CM-G versions are available with this number of stages.

** Applies to supply voltage O.

*** Applies to supply voltage J.

1 x 115/230 V, 60 Hz (supply voltage B)

1 x 220 V, 60 Hz (supply voltage A)

Pump type	Frame size	P ₂ [kW]	Dimensions [mm]																		
			A1	A2	A3	A4	B1	B2	B3	H	H1	H2	L1	L2	L3	L4	L5	L6	L7	L8	L9
CM 5-2	80	0.78*/0.84	1"	1 1/4"	3/8"	10	142	158	125	208	75	165	345	131	107	72	96	137	60	214	274
CM 5-3	80	1.10*/1.14	1"	1 1/4"	3/8"	10	205	158	125	208	75	165	345	131	107	72	96	137	60	214	274
CM 5-4	90	1.50*/1.54	1"	1 1/4"	3/8"	10	178	178	140	229	90	180	413	189	174	90	125	155	99	224	323

* Applies to supply voltage B.

3 x 200/346 V, 50 Hz; 3 x 200-220/346-380 V, 60 Hz (supply voltage G)

Pump type	Frame size	P ₂ [kW]		Dimensions [mm]																		
		50 Hz	60 Hz	A1	A2	A3	A4	B1	B2	B3	H	H1	H2	L1	L2	L3	L4	L5	L6	L7	L8	L9
CM 5-2	71	0.43	0.74	1"	1 1/4"	3/8"	10	142	158	125	184	75	165	305	131	107	72	96	137	60	174	234
CM 5-3	80	0.60	1.04	1"	1 1/4"	3/8"	10	142	158	125	184	75	165	345	131	107	72	96	137	60	214	274
CM 5-4	90	0.87	1.70	1"	1 1/4"	3/8"	10	178	178	140	200	90	180	413	189	174	90	125	155	99	224	323
CM 5-5	90	1.40	2.50	1"	1 1/4"	3/8"	10	178	178	140	200	90	180	431	207	192	108	125	155	99	224	323
CM 5-6	90	1.40	2.50	1"	1 1/4"	3/8"	10	178	178	140	200	90	180	467	243	228	144	125	155	99	224	323
CM 5-7	90	1.40	2.50	1"	1 1/4"	3/8"	10	178	178	140	200	90	180	467	243	228	144	125	155	99	224	323
CM 5-8	100	2.30	4.00	1"	1 1/4"	3/8"	10	198	199	160	220	100	190	561	289	274	180	140	170	109	272	381

Dimensions, CM 60 Hz and 50/60 Hz

CM 10-A
60 Hz
50/60 Hz

CM 10-A

(A = cast iron, EN-GJL-200)

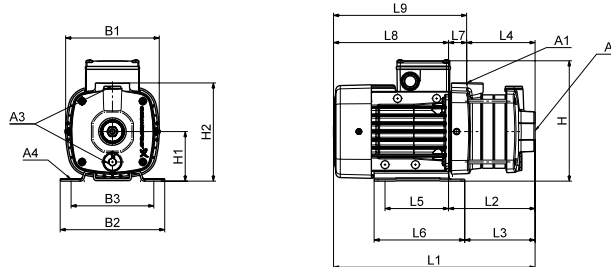

TM04 2248 2208

Dimensions

3 x 208-230 V / 440-480 V, 60 Hz (supply voltage E)

3 x 575 V, 60 Hz (supply voltage H)

3 x 400 V, 50/60 Hz (supply voltage I)

3 x 380-415 V, 50 Hz; 3 x 440-480 V, 60 Hz (supply voltage J)

3 x 220-240/380-415 V, 50 Hz; 3 x 220-255/380-440 V, 60 Hz (supply voltage O)

Pump type	Frame size	P ₂ [kW]		Dimensions [mm]																		
		50 Hz	60 Hz	A1	A2	A3	A4	B1	B2	B3	H	H1	H2	L1	L2	L3	L4	L5	L6	L7	L8	L9
CM 10-1	80	0.74	1.28	1 1/2"	1 1/2"	3/8"	10	190	158	125	216	100	245	369	155	131	97	96	137	58	214	272
CM 10-2	90	1.45	2.52	1 1/2"	1 1/2"	3/8"	10	190	199	160	210	100	245	421	219	204	97	140	170	114	232	324
CM 10-3	100	2.30	4.00	1 1/2"	1 1/2"	3/8"	10	198	199	160	220	100	245	507	235	220	127	140	170	108	272	380

1 x 115/230 V, 60 Hz (supply voltage B)

1 x 220 V, 60 Hz (supply voltage A)

Pump type	Frame size	P ₂ [kW]	Dimensions [mm]																		
			A1	A2	A3	A4	B1	B2	B3	H	H1	H2	L1	L2	L3	L4	L5	L6	L7	L8	L9
CM 10-1	80	1.10*/1.14	1 1/2"	1 1/2"	3/8"	10	205	158	125	233	100	245	369	155	131	97	96	137	58	214	272

* Applies to supply voltage B.

3 x 200/346 V, 50 Hz; 3 x 200-220/346-380 V, 60 Hz (supply voltage G)

Pump type	Frame size	P ₂ [kW]		Dimensions [mm]																		
		50 Hz	60 Hz	A1	A2	A3	A4	B1	B2	B3	H	H1	H2	L1	L2	L3	L4	L5	L6	L7	L8	L9
CM 10-1	80	0.74	1.28	1 1/2"	1 1/2"	3/8"	10	190	158	125	209	100	245	369	155	131	97	96	137	58	214	272
CM 10-2	90	1.40	2.50	1 1/2"	1 1/2"	3/8"	10	190	199	160	210	100	245	421	190	175	97	140	170	93	232	324
CM 10-3	100	2.30	4.00	1 1/2"	1 1/2"	3/8"	10	198	199	160	220	100	245	507	235	220	127	140	170	108	272	380

Dimensions, CM 60 Hz and 50/60 Hz

CM 10-I and CM 10-G
60 Hz
50/60 Hz

CM 10-I and CM 10-G

(I = EN 1.4301/AISI 304 and G = EN 1.4401/AISI 316)

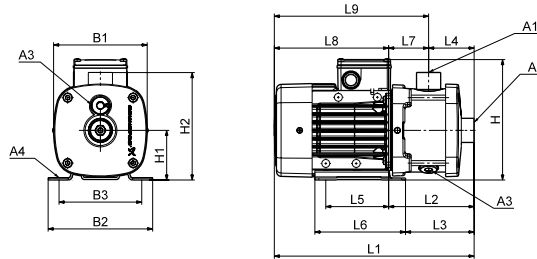

TM04 2246 2208

Dimensions

3 x 208-230 V / 440-480 V, 60 Hz (supply voltage E)

3 x 575 V, 60 Hz (supply voltage H)

3 x 400 V, 50/60 Hz (supply voltage I)

3 x 380-415 V, 50 Hz; 3 x 440-480 V, 60 Hz (supply voltage J)

3 x 220-240/380-415 V, 50 Hz; 3 x 220-255/380-440 V, 60 Hz (supply voltage O)

Pump type	Frame size	P ₂ [kW]		Dimensions [mm]																		
		50 Hz	60 Hz	A1	A2	A3	A4	B1	B2	B3	H	H1	H2	L1	L2	L3	L4	L5	L6	L7	L8	L9
CM 10-1	80	0.74	1.28	1 1/2"	1 1/2"	3/8"	10	180	158	125	216	100	218	399	185	161	105	96	137	80	214	294
CM 10-2	90	1.45	2.52	1 1/2"	1 1/2"	3/8"	10	180	199	160	210	100	218	450	179	164	105	140	170	74	272	345
CM 10-3	100	2.30	4.00	1 1/2"	1 1/2"	3/8"	10	198	199	160	220	100	218	507	235	220	105	140	170	130	272	402
CM 10-4	112	3.60	6.20	1 1/2"	1 1/2"	3/8"	12	220	228	190	246	112	230	589	287	271	135	140	172	152	302	454
CM 10-5	112	3.60	6.20	1 1/2"	1 1/2"	3/8"	12	220	228	190	246	112	230	649	347	331	195	140	172	152	302	454

1 x 115/230 V, 60 Hz (supply voltage B)

1 x 220 V, 60 Hz (supply voltage A)

Pump type	Frame size	P ₂ [kW]		Dimensions [mm]																		
		50 Hz	60 Hz	A1	A2	A3	A4	B1	B2	B3	H	H1	H2	L1	L2	L3	L4	L5	L6	L7	L8	L9
CM 10-1	80	1.10*	1.14	1 1/2"	1 1/2"	3/8"	10	205	158	125	233	100	218	399	185	161	105	96	137	80	214	294

* Applies to supply voltage B.

3 x 200/346 V, 50 Hz; 3 x 200-220/346-380 V, 60 Hz (supply voltage G)

Pump type	Frame size	P ₂ [kW]		Dimensions [mm]																		
		50 Hz	60 Hz	A1	A2	A3	A4	B1	B2	B3	H	H1	H2	L1	L2	L3	L4	L5	L6	L7	L8	L9
CM 10-1	80	0.74	1.28	1 1/2"	1 1/2"	3/8"	10	180	158	125	209	100	218	399	185	161	105	96	137	80	214	294
CM 10-2	90	1.40	2.50	1 1/2"	1 1/2"	3/8"	10	180	199	160	210	100	218	450	219	204	105	140	170	114	232	345
CM 10-3	100	2.30	4.00	1 1/2"	1 1/2"	3/8"	10	198	199	160	220	100	218	507	235	220	105	140	170	130	272	402
CM 10-4	112	3.60	6.20	1 1/2"	1 1/2"	3/8"	12	220	228	190	246	112	230	589	287	271	135	140	172	152	302	454
CM 10-5	112	3.60	6.20	1 1/2"	1 1/2"	3/8"	12	220	228	190	246	112	230	649	347	331	195	140	172	152	302	454

Dimensions, CM 60 Hz and 50/60 Hz

CM 15-A
60 Hz
50/60 Hz

CM 15-A

(A = cast iron, EN-GJL-200)

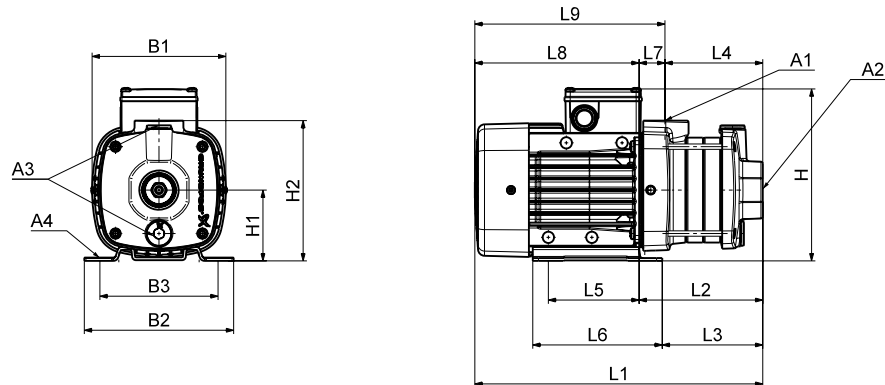

TM04 2248 2208

Dimensions

3 x 208-230 V / 440-480 V, 60 Hz (supply voltage E)

3 x 575 V, 60 Hz (supply voltage H)

3 x 400 V, 50/60 Hz (supply voltage I)

3 x 380-415 V, 50 Hz; 3 x 440-480 V, 60 Hz (supply voltage J)

3 x 220-240/380-415 V, 50 Hz; 3 x 220-255/380-440 V, 60 Hz (supply voltage O)

Pump type	Frame size	P ₂ [kW]		Dimensions [mm]																		
		50 Hz	60 Hz	A1	A2	A3	A4	B1	B2	B3	H	H1	H2	L1	L2	L3	L4	L5	L6	L7	L8	L9
CM 15-1	90	1.45	2.52	2"	2"	3/8"	10	190	199	160	210	100	245	421	190	175	97	140	170	93	232	324
CM 15-2	100	2.30	4.00	2"	2"	3/8"	10	198	199	160	220	100	245	477	205	190	97	140	170	108	272	380
CM 15-3	112	3.60	6.20	2"	2"	3/8"	12	220	228	190	246	112	257	560	258	242	127	140	172	131	302	433

3 x 200/346 V, 50 Hz; 3 x 200-220/346-380 V, 60 Hz (supply voltage G)

Pump type	Frame size	P ₂ [kW]		Dimensions [mm]																		
		50 Hz	60 Hz	A1	A2	A3	A4	B1	B2	B3	H	H1	H2	L1	L2	L3	L4	L5	L6	L7	L8	L9
CM 15-1	90	1.40	2.50	2"	2"	3/8"	10	190	199	160	210	100	245	421	190	175	97	140	170	93	232	324
CM 15-2	100	2.30	4.00	2"	2"	3/8"	10	198	199	160	220	100	245	477	205	190	97	140	170	108	272	380
CM 15-3	112	3.60	6.20	2"	2"	3/8"	12	220	228	190	246	112	257	560	258	242	127	140	172	131	302	433

Dimensions, CM 60 Hz and 50/60 Hz

CM 15-I and CM 15-G
60 Hz
50/60 Hz

CM 15-I and CM 15-G

(I = EN 1.4301/AISI 304 and G = EN 1.4401/AISI 316)

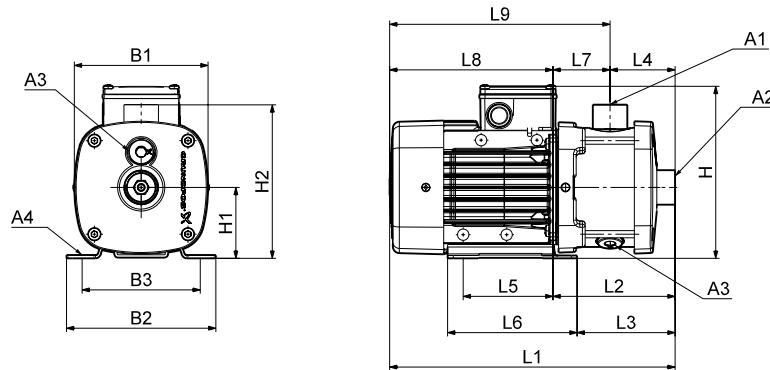

TM04 2246 2208

Dimensions

3 x 208-230 V / 440-480 V, 60 Hz (supply voltage E)

3 x 575 V, 60 Hz (supply voltage H)

3 x 400 V, 50/60 Hz (supply voltage I)

3 x 380-415 V, 50 Hz; 3 x 440-480 V, 60 Hz (supply voltage J)

3 x 220-240/380-415 V, 50 Hz; 3 x 220-255/380-440 V, 60 Hz (supply voltage O)

Pump type	Frame size	P ₂ [kW]		Dimensions [mm]																		
		50 Hz	60 Hz	A1	A2	A3	A4	B1	B2	B3	H	H1	H2	L1	L2	L3	L4	L5	L6	L7	L8	L9
CM 15-1	90	1.45	2.52	2"	2"	3/8"	10	180	199	160	210	100	218	450	219	204	105	140	170	114	232	345
CM 15-2	100	2.30	4.00	2"	2"	3/8"	10	198	199	160	220	100	218	507	235	220	105	140	170	130	272	402
CM 15-3	112	3.60	6.20	2"	2"	3/8"	12	220	228	190	246	112	230	559	257	241	105	140	172	152	302	454

3 x 200/346 V, 50 Hz; 3 x 200-220/346-380 V, 60 Hz (supply voltage G)

Pump type	Frame size	P ₂ [kW]		Dimensions [mm]																		
		50 Hz	60 Hz	A1	A2	A3	A4	B1	B2	B3	H	H1	H2	L1	L2	L3	L4	L5	L6	L7	L8	L9
CM 15-1	90	1.40	2.50	2"	2"	3/8"	10	180	199	160	210	100	218	450	219	204	105	140	170	114	232	345
CM 15-2	100	2.30	4.00	2"	2"	3/8"	10	198	199	160	220	100	218	507	235	220	105	140	170	130	272	402
CM 15-3	112	3.60	6.20	2"	2"	3/8"	12	220	228	190	246	112	230	559	257	241	105	140	172	152	302	454

Dimensions, CM 60 Hz and 50/60 Hz

CM 25-A
60 Hz
50/60 Hz

CM 25-A

(A = cast iron, EN-GJL-200)

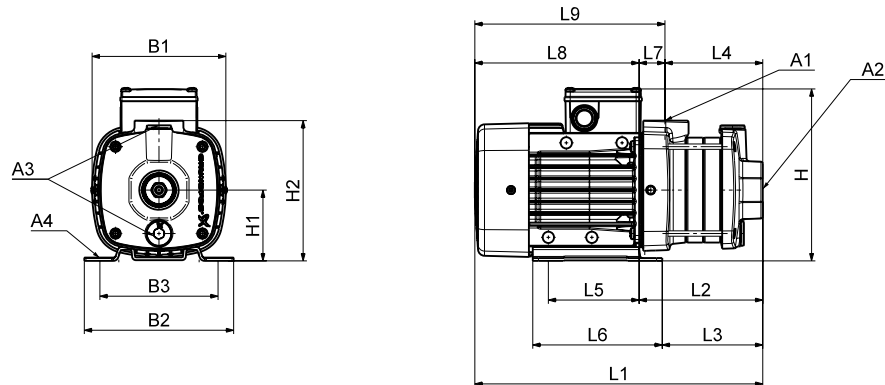

TM04 2248 2208

Dimensions

3 x 208-230 V / 440-480 V, 60 Hz (supply voltage E)

3 x 575 V, 60 Hz (supply voltage H)

3 x 400 V, 50/60 Hz (supply voltage I)

3 x 380-415 V, 50 Hz; 3 x 440-480 V, 60 Hz (supply voltage J)

3 x 220-240/380-415 V, 50 Hz; 3 x 220-255/380-440 V, 60 Hz (supply voltage O)

Pump type	Frame size	P ₂ [kW]		Dimensions [mm]																		
		50 Hz	60 Hz	A1	A2	A3	A4	B1	B2	B3	H	H1	H2	L1	L2	L3	L4	L5	L6	L7	L8	L9
CM 25-1	100	2.30	4.00	2"	2"	3/8"	10	198	199	160	220	100	245	477	205	190	97	140	170	108	272	380
CM 25-2	112	3.60	6.20	2"	2"	3/8"	12	220	228	190	246	112	257	530	228	212	97	140	172	131	302	433

3 x 200/346 V, 50 Hz; 3 x 200-220/346-380 V, 60 Hz (supply voltage G)

Pump type	Frame size	P ₂ [kW]		Dimensions [mm]																		
		50 Hz	60 Hz	A1	A2	A3	A4	B1	B2	B3	H	H1	H2	L1	L2	L3	L4	L5	L6	L7	L8	L9
CM 25-1	100	2.30	4.00	2"	2"	3/8"	10	198	199	160	220	100	245	477	205	190	97	140	170	108	272	380
CM 25-2	112	3.60	6.20	2"	2"	3/8"	12	220	228	190	246	112	257	530	228	212	97	140	172	131	302	433

Dimensions, CM 60 Hz and 50/60 Hz

CM 25-I and CM 25-G
60 Hz
50/60 Hz

CM 25-I and CM 25-G

(I = EN 1.4301/AISI 304 and G = EN 1.4401/AISI 316)

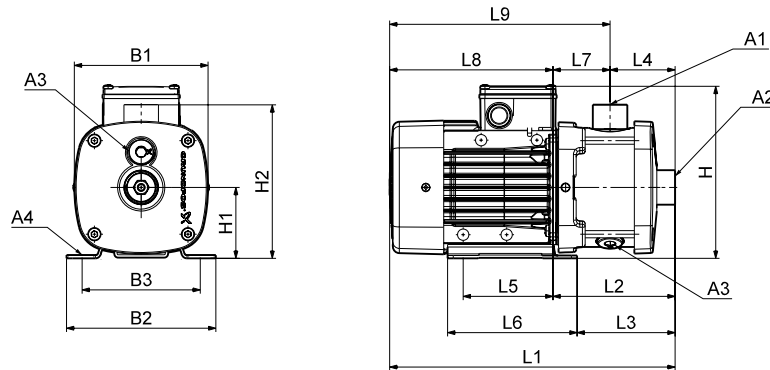

TM04 2246 2208

Dimensions

3 x 208-230 V / 440-480 V, 60 Hz (supply voltage E)

3 x 575 V, 60 Hz (supply voltage H)

3 x 400 V, 50/60 Hz (supply voltage I)

3 x 380-415 V, 50 Hz; 3 x 440-480 V, 60 Hz (supply voltage J)

3 x 220-240/380-415 V, 50 Hz; 3 x 220-255/380-440 V, 60 Hz (supply voltage O)

Pump type	Frame size	P ₂ [kW]		Dimensions [mm]																		
		50 Hz	60 Hz	A1	A2	A3	A4	B1	B2	B3	H	H1	H2	L1	L2	L3	L4	L5	L6	L7	L8	L9
CM 25-1	100	2.30	4.00	2"	2"	3/8"	10	198	199	160	220	100	218	507	235	220	105	140	170	130	272	402
CM 25-2	112	3.60	6.20	2"	2"	3/8"	12	220	228	190	246	112	230	559	257	241	105	140	172	152	302	454

3 x 200/346 V, 50 Hz; 3 x 200-220/346-380 V, 60 Hz (supply voltage M)

Pump type	Frame size	P ₂ [kW]		Dimensions [mm]																		
		50 Hz	60 Hz	A1	A2	A3	A4	B1	B2	B3	H	H1	H2	L1	L2	L3	L4	L5	L6	L7	L8	L9
CM 25-1	100	2.30	4.00	2"	2"	3/8"	10	198	199	160	220	100	218	507	235	220	105	140	170	130	272	402
CM 25-2	112	3.60	6.20	2"	2"	3/8"	12	220	228	190	246	112	230	559	257	241	105	140	172	152	302	454

Dimensions, CME 60 Hz and 50/60 Hz

CME 1-A
60 Hz
50/60 Hz

CME 1-A

(A = cast iron, EN-GJL-200)

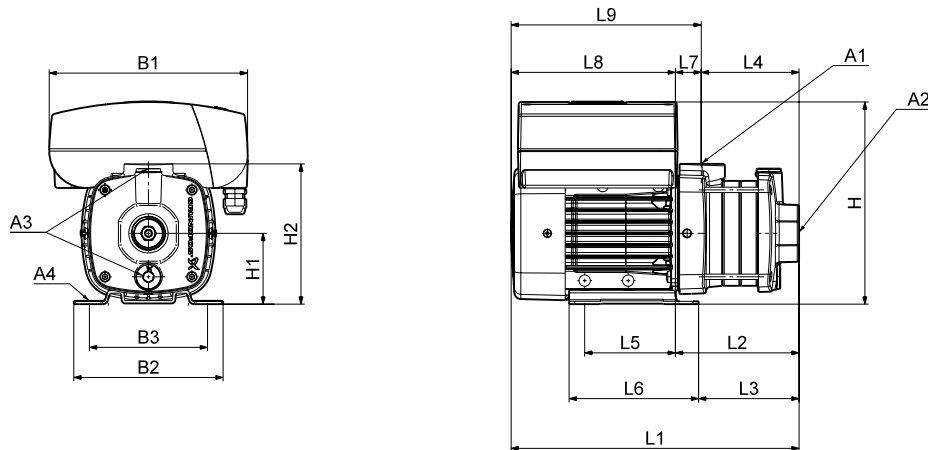

TM04 22:49 2208

Dimensions

1 x 220-240 V, 50/60 Hz (supply voltage K)

1 x 208-230 V, 50/60 Hz (supply voltage M)

Pump type	Frame size	P ₂ [kW]	Dimensions [mm]																		
			A1	A2	A3	A4	B1	B2	B3	H	H1	H2	L1	L2	L3	L4	L5	L6	L7	L8	L9
CME 1-2	71	0.55	1"	1"	3/8"	10	210	158	125	215	75	149	288	114	89	86	96	137	28	174	202
CME 1-3	71	0.55	1"	1"	3/8"	10	210	158	125	215	75	149	306	132	107	104	96	137	28	174	202
CME 1-4	71	0.55	1"	1"	3/8"	10	210	158	125	215	75	149	324	150	125	122	96	137	28	174	202
CME 1-5	80	1.10	1"	1"	3/8"	10	210	158	125	215	75	149	382	168	143	140	96	137	28	214	242

Dimensions, CME 60 Hz and 50/60 Hz

CME 1-I and CME 1-G
60 Hz
50/60 Hz

CME 1-I and CME 1-G

(I = EN 1.4301/AISI 304 and G = EN 1.4401/AISI 316)

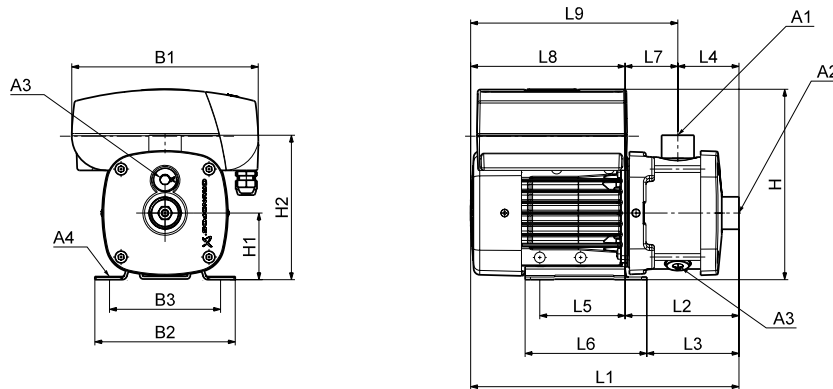

TM04 2247 2208

Dimensions

1 x 220-240 V, 50/60 Hz (supply voltage K)

1 x 208-230 V, 50/60 Hz (supply voltage M)

Pump type	Frame size	P ₂ [kW]	Dimensions [mm]																		
			A1	A2	A3	A4	B1	B2	B3	H	H1	H2	L1	L2	L3	L4	L5	L6	L7	L8	L9
CME 1-2	71	0.55	1"	1"	3/8"	10	210	158	125	215	75	165	305	131	107	72	96	137	60	174	234
CME 1-3	71	0.55	1"	1"	3/8"	10	210	158	125	215	75	165	305	131	107	72	96	137	60	174	234
CME 1-4	71	0.55	1"	1"	3/8"	10	210	158	125	215	75	165	323	149	125	90	96	137	60	174	234
CME 1-5	80	1.10	1"	1"	3/8"	10	210	158	125	215	75	165	381	167	143	108	96	137	60	214	274
CME 1-6	80	1.10	1"	1"	3/8"	10	210	158	125	215	75	165	417	203	179	144	96	137	60	214	274
CME 1-7	80	1.10	1"	1"	3/8"	10	210	158	125	215	75	165	417	203	179	144	96	137	60	214	274
CME 1-8	80	1.10	1"	1"	3/8"	10	210	158	125	215	75	165	453	239	215	180	96	137	60	214	274

3 x 380-480 V, 50/60 Hz (supply voltage L)

Pump type	Frame size	P ₂ [kW]	Dimensions [mm]																		
			A1	A2	A3	A4	B1	B2	B3	H	H1	H2	L1	L2	L3	L4	L5	L6	L7	L8	L9
CME 1-9	90	1.50	1"	1"	3/8"	10	264	178	140	257	90	180	503	279	264	180	125	155	99	224	323

3 x 460-480 V, 60 Hz (supply voltage N)

Pump type	Frame size	P ₂ [kW]	Dimensions [mm]																		
			A1	A2	A3	A4	B1	B2	B3	H	H1	H2	L1	L2	L3	L4	L5	L6	L7	L8	L9
CME 1-9	90	1.50	1"	1"	3/8"	10	264	178	140	257	90	180	503	279	264	180	125	155	99	224	323

Dimensions, CME 60 Hz and 50/60 Hz

CME 3-A
60 Hz
50/60 Hz

CME 3-A

(A = cast iron, EN-GJL-200)

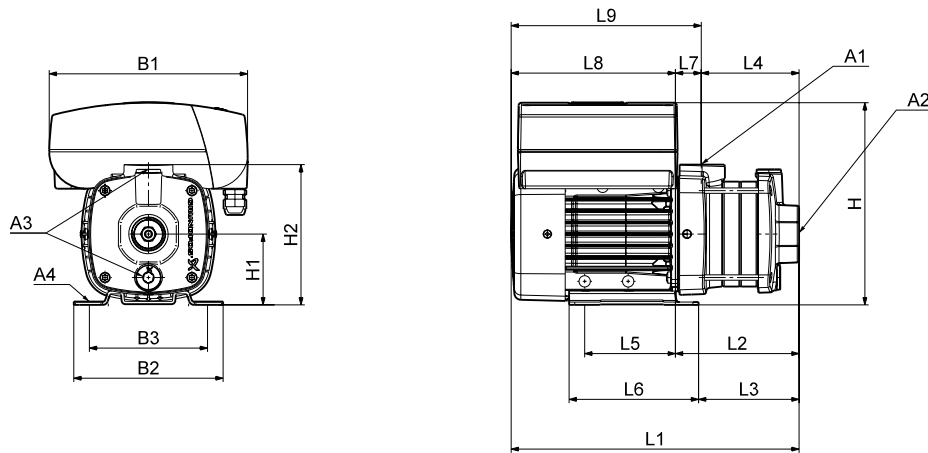

TM04 2249 2208

Dimensions

1 x 220-240 V, 50/60 Hz (supply voltage K)

1 x 208-230 V, 50/60 Hz (supply voltage M)

Pump type	Frame size	P ₂ [kW]	Dimensions [mm]																		
			A1	A2	A3	A4	B1	B2	B3	H	H1	H2	L1	L2	L3	L4	L5	L6	L7	L8	L9
CME 3-2	71	0.55	1"	1"	3/8"	10	210	158	125	215	75	149	288	114	89	86	96	137	28	174	202
CME 3-3	80	1.10	1"	1"	3/8"	10	210	158	125	215	75	149	346	132	107	104	96	137	28	214	242
CME 3-4	80	1.10	1"	1"	3/8"	10	210	158	125	215	75	149	364	150	125	122	96	137	28	214	242
CME 3-5	80	1.10	1"	1"	3/8"	10	210	158	125	215	75	149	382	168	143	140	96	137	28	214	242

Dimensions, CME 60 Hz and 50/60 Hz

CME 3-I and CME 3-G
60 Hz
50/60 Hz

CME 3-I and CME 3-G

(I = EN 1.4301/AISI 304 and G = EN 1.4401/AISI 316)

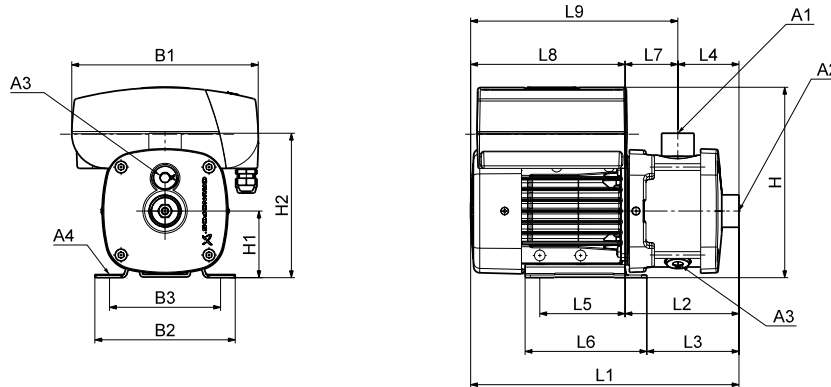

TM04 2247 2208

Dimensions

1 x 220-240 V, 50/60 Hz (supply voltage K)

1 x 208-230 V, 50/60 Hz (supply voltage M)

Pump type	Frame size	P ₂ [kW]	Dimensions [mm]																		
			A1	A2	A3	A4	B1	B2	B3	H	H1	H2	L1	L2	L3	L4	L5	L6	L7	L8	L9
CME 3-2	71	0.55	1"	1"	3/8"	10	210	158	125	215	75	165	305	131	107	72	96	137	60	174	234
CME 3-3	80	1.10	1"	1"	3/8"	10	210	158	125	215	75	165	345	131	107	72	96	137	60	214	274
CME 3-4	80	1.10	1"	1"	3/8"	10	210	158	125	215	75	165	363	149	125	90	96	137	60	214	274
CME 3-5	80	1.10	1"	1"	3/8"	10	210	158	125	215	75	165	381	167	143	108	96	137	60	214	274

3 x 380-480 V, 50/60 Hz (supply voltage L)

Pump type	Frame size	P ₂ [kW]	Dimensions [mm]																		
			A1	A2	A3	A4	B1	B2	B3	H	H1	H2	L1	L2	L3	L4	L5	L6	L7	L8	L9
CME 3-6	90	1.50	1"	1"	3/8"	10	264	178	140	257	90	180	467	243	228	144	125	155	99	224	323
CME 3-7	90	1.50	1"	1"	3/8"	10	264	178	140	257	90	180	467	243	228	144	125	155	99	224	323
CME 3-8	90	2.20	1"	1"	3/8"	10	264	178	140	257	90	180	543	279	264	180	125	155	99	264	363
CME 3-9	90	2.20	1"	1"	3/8"	10	264	178	140	257	90	180	543	279	264	180	125	155	99	264	363

3 x 460-480 V, 60 Hz (supply voltage N)

Pump type	Frame size	P ₂ [kW]	Dimensions [mm]																		
			A1	A2	A3	A4	B1	B2	B3	H	H1	H2	L1	L2	L3	L4	L5	L6	L7	L8	L9
CME 3-6	90	1.50	1"	1"	3/8"	10	264	178	140	257	90	180	467	243	228	144	125	155	99	224	323
CME 3-7	90	1.50	1"	1"	3/8"	10	264	178	140	257	90	180	467	243	228	144	125	155	99	224	323
CME 3-8	90	1.50	1"	1"	3/8"	10	264	178	140	257	90	180	503	279	264	180	125	155	99	224	323
CME 3-9	90	2.20	1"	1"	3/8"	10	264	178	140	257	90	180	543	279	264	180	125	155	99	264	363

Dimensions, CME 60 Hz and 50/60 Hz

CME 5-A
60 Hz
50/60 Hz

CME 5-A

(A = cast iron, EN-GJL-200)

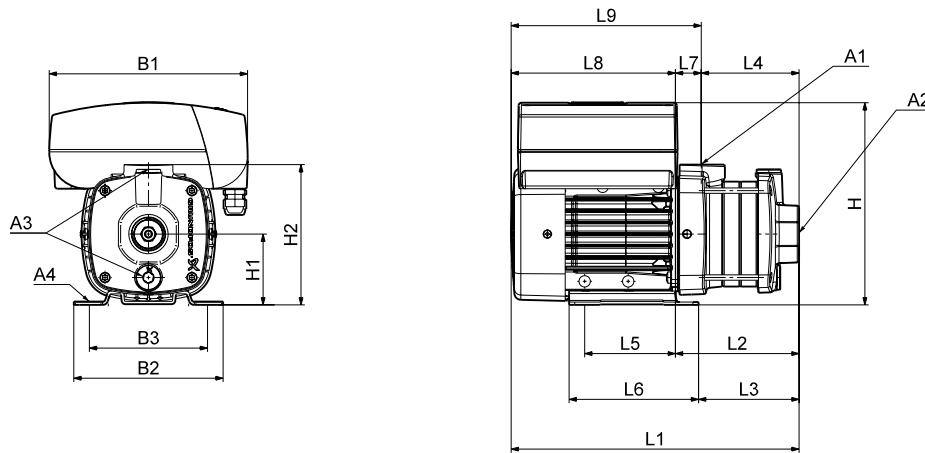

TM04 2249 2208

Dimensions

1 x 220-240 V, 50/60 Hz (supply voltage K)

1 x 208-230 V, 50/60 Hz (supply voltage M)

Pump type	Frame size	P ₂ [kW]	Dimensions [mm]																		
			A1	A2	A3	A4	B1	B2	B3	H	H1	H2	L1	L2	L3	L4	L5	L6	L7	L8	L9
CME 5-2	80	1.10	1"	1 1/4"	3/8"	10	210	158	125	215	75	149	328	114	89	86	96	137	28	214	242
CME 5-3	80	1.10	1"	1 1/4"	3/8"	10	210	158	125	215	75	149	345	131	107	104	96	137	28	214	242

3 x 380-480 V, 50/60 Hz (supply voltage L)

Pump type	Frame size	P ₂ [kW]	Dimensions [mm]																		
			A1	A2	A3	A4	B1	B2	B3	H	H1	H2	L1	L2	L3	L4	L5	L6	L7	L8	L9
CME 5-4	90	1.50	1"	1 1/4"	3/8"	10	264	178	140	257	90	201	415	191	176	109	125	155	82	224	306
CME 5-5	90	2.20	1"	1 1/4"	3/8"	10	264	178	140	257	90	201	473	209	194	127	125	155	82	264	346

3 x 460-480 V, 60 Hz (supply voltage N)

Pump type	Frame size	P ₂ [kW]	Dimensions [mm]																		
			A1	A2	A3	A4	B1	B2	B3	H	H1	H2	L1	L2	L3	L4	L5	L6	L7	L8	L9
CME 5-4	90	1.50	1"	1 1/4"	3/8"	10	264	178	140	257	90	201	415	191	176	109	125	155	82	224	306
CME 5-5	90	1.50	1"	1 1/4"	3/8"	10	264	178	140	257	90	201	433	209	194	127	125	155	82	224	306

Dimensions, CME 60 Hz and 50/60 Hz

CME 5-I and CME 5-G
60 Hz
50/60 Hz

CME 5-I and CME 5-G

(I = EN 1.4301/AISI 304 and G = EN 1.4401/AISI 316)

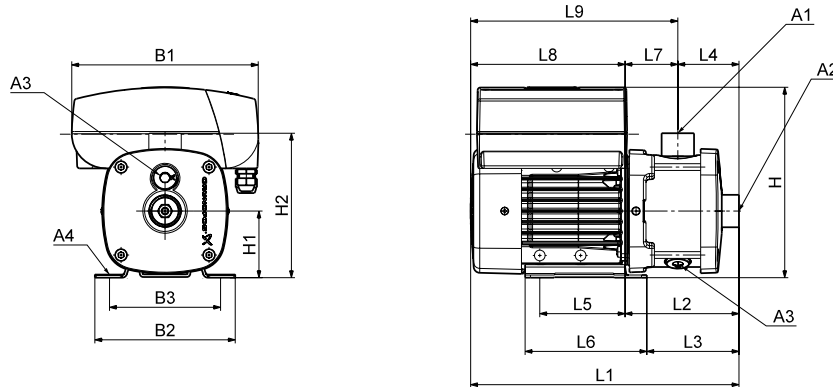

TM04 2247 2208

Dimensions

1 x 220-240 V, 50/60 Hz (supply voltage K)

1 x 208-230 V, 50/60 Hz (supply voltage M)

Pump type	Frame size	P ₂ [kW]	Dimensions [mm]																		
			A1	A2	A3	A4	B1	B2	B3	H	H1	H2	L1	L2	L3	L4	L5	L6	L7	L8	L9
CME 5-2	80	1.10	1"	1 1/4"	3/8"	10	210	158	125	215	75	165	345	131	107	72	96	137	60	214	274
CME 5-3	80	1.10	1"	1 1/4"	3/8"	10	210	158	125	215	75	165	345	131	107	72	96	137	60	214	274

3 x 380-480 V, 50/60 Hz (supply voltage L)

Pump type	Frame size	P ₂ [kW]	Dimensions [mm]																		
			A1	A2	A3	A4	B1	B2	B3	H	H1	H2	L1	L2	L3	L4	L5	L6	L7	L8	L9
CME 5-4	90	1.50	1"	1 1/4"	3/8"	10	264	178	140	257	90	180	413	189	174	90	125	155	99	224	323
CME 5-5	90	2.20	1"	1 1/4"	3/8"	10	264	178	140	257	90	180	471	207	192	108	125	155	99	264	363
CME 5-6	90	2.20	1"	1 1/4"	3/8"	10	264	178	140	257	90	180	507	243	228	144	125	155	99	264	363
CME 5-7	100	3.00	1"	1 1/4"	3/8"	10	264	198	160	277	100	190	525	253	238	144	140	170	109	272	381
CME 5-8	100	3.00	1"	1 1/4"	3/8"	10	264	198	160	277	100	190	561	289	274	180	140	170	109	272	381

3 x 460-480 V, 60 Hz (supply voltage N)

Pump type	Frame size	P ₂ [kW]	Dimensions [mm]																		
			A1	A2	A3	A4	B1	B2	B3	H	H1	H2	L1	L2	L3	L4	L5	L6	L7	L8	L9
CME 5-4	90	1.50	1"	1 1/4"	3/8"	10	264	178	140	257	90	180	413	189	174	90	125	155	99	224	323
CME 5-5	90	2.20	1"	1 1/4"	3/8"	10	264	178	140	257	90	180	431	207	192	108	125	155	99	224	323
CME 5-6	90	2.20	1"	1 1/4"	3/8"	10	264	178	140	257	90	180	507	243	228	144	125	155	99	264	363
CME 5-7	90	2.20	1"	1 1/4"	3/8"	10	264	178	140	257	90	180	507	243	235	144	140	155	99	264	363

Dimensions, CME 60 Hz and 50/60 Hz

CME 10-A
60 Hz
50/60 Hz

CME 10-A

(A = cast iron, EN-GJL-200)

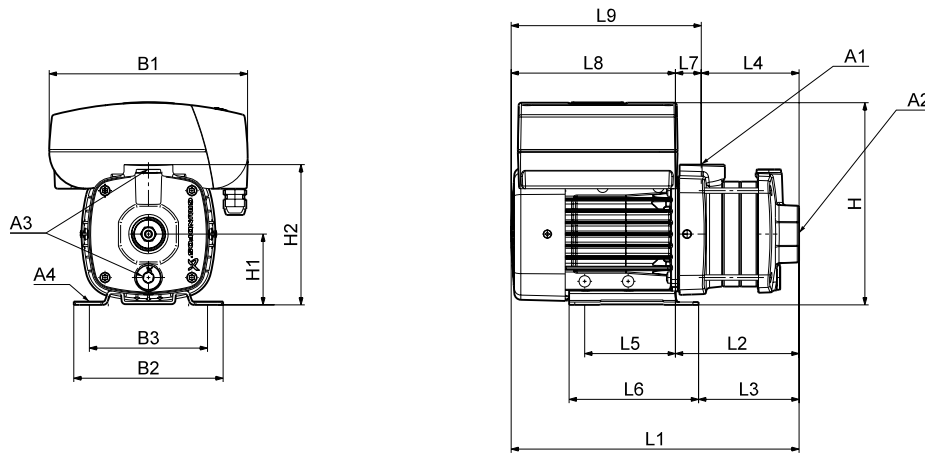

TM04 2249 2208

Dimensions

1 x 220-240 V, 50/60 Hz (supply voltage K)

1 x 208-230 V, 50/60 Hz (supply voltage M)

Pump type	Frame size	P ₂ [kW]	Dimensions [mm]																		
			A1	A2	A3	A4	B1	B2	B3	H	H1	H2	L1	L2	L3	L4	L5	L6	L7	L8	L9
CME 10-1	80	1.10	1 1/2"	1 1/2"	3/8"	10	210	158	125	240	100	245	339	125	101	67	96	137	58	214	272

3 x 380-480 V, 50/60 Hz (supply voltage L)

Pump type	Frame size	P ₂ [kW]	Dimensions [mm]																		
			A1	A2	A3	A4	B1	B2	B3	H	H1	H2	L1	L2	L3	L4	L5	L6	L7	L8	L9
CME 10-2	90	2.20	1 1/2"	1 1/2"	3/8"	10	264	199	160	267	100	245	461	190	175	97	140	170	93	272	364
CME 10-3	112	5.50	1 1/2"	1 1/2"	3/8"	12	290	228	190	300	112	257	560	258	242	127	140	172	131	302	433

3 x 460-480 V, 60 Hz (supply voltage N)

Pump type	Frame size	P ₂ [kW]	Dimensions [mm]																		
			A1	A2	A3	A4	B1	B2	B3	H	H1	H2	L1	L2	L3	L4	L5	L6	L7	L8	L9
CME 10-2	90	2.20	1 1/2"	1 1/2"	3/8"	10	264	199	160	267	100	245	461	190	175	97	140	170	93	272	364
CME 10-3	112	4.00	1 1/2"	1 1/2"	3/8"	12	290	228	190	300	112	257	560	258	242	127	140	172	131	302	433

Dimensions, CME 60 Hz and 50/60 Hz

CME 10-I and CME 10-G
60 Hz
50/60 Hz

CME 10-I and CME 10-G

(I = EN 1.4301/AISI 304 and G = EN 1.4401/AISI 316)

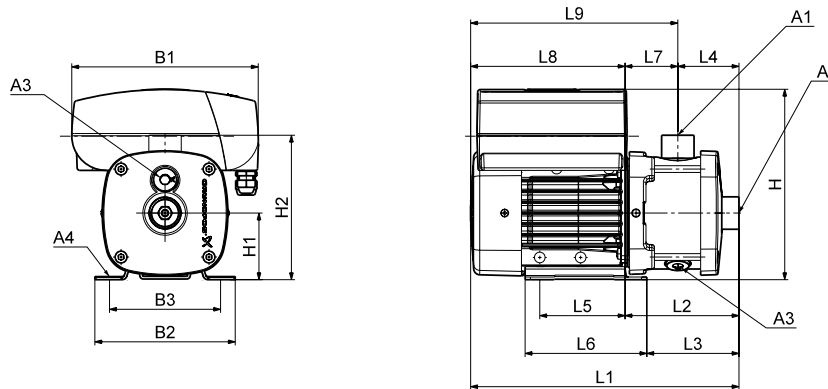

TM04-2247 2208

Dimensions

1 x 220-240 V, 50/60 Hz (supply voltage K)

1 x 208-230 V, 50/60 Hz (supply voltage M)

Pump type	Frame size	P ₂ [kW]	Dimensions [mm]																		
			A1	A2	A3	A4	B1	B2	B3	H	H1	H2	L1	L2	L3	L4	L5	L6	L7	L8	L9
CME 10-1	80	1.10	1 1/2"	1 1/2"	3/8"	10	210	158	125	240	100	218	399	185	161	105	96	137	80	214	294

3 x 380-480 V, 50/60 Hz (supply voltage L)

Pump type	Frame size	P ₂ [kW]	Dimensions [mm]																		
			A1	A2	A3	A4	B1	B2	B3	H	H1	H2	L1	L2	L3	L4	L5	L6	L7	L8	L9
CME 10-2	90	2.20	1 1/2"	1 1/2"	3/8"	10	264	199	160	267	100	218	490	219	204	105	140	170	114	272	385
CME 10-3	112	5.50	1 1/2"	1 1/2"	3/8"	12	290	228	190	300	112	230	559	257	241	105	140	172	152	302	454
CME 10-4	112	5.50	1 1/2"	1 1/2"	3/8"	12	290	228	190	300	112	230	589	287	271	135	140	172	152	302	454
CME 10-5	112	5.50	1 1/2"	1 1/2"	3/8"	12	290	228	190	300	112	230	649	347	331	195	140	172	152	302	454

3 x 460-480 V, 60 Hz (supply voltage N)

Pump type	Frame size	P ₂ [kW]	Dimensions [mm]																		
			A1	A2	A3	A4	B1	B2	B3	H	H1	H2	L1	L2	L3	L4	L5	L6	L7	L8	L9
CME 10-2	90	2.20	1 1/2"	1 1/2"	3/8"	10	264	199	160	267	100	218	490	219	204	105	140	170	114	272	385
CME 10-3	112	4.00	1 1/2"	1 1/2"	3/8"	12	290	228	190	300	112	230	559	257	241	105	140	172	152	302	454
CME 10-4	112	4.00	1 1/2"	1 1/2"	3/8"	12	290	228	190	300	112	230	589	287	271	135	140	172	152	302	454
CME 10-5	132	5.50	1 1/2"	1 1/2"	3/8"	12	290	228	190	300	112	230	649	347	331	195	140	172	152	302	454

Dimensions, CME 60 Hz and 50/60 Hz

CME 15-A
60 Hz
50/60 Hz

CME 15-A

(A = cast iron, EN-GJL-200)

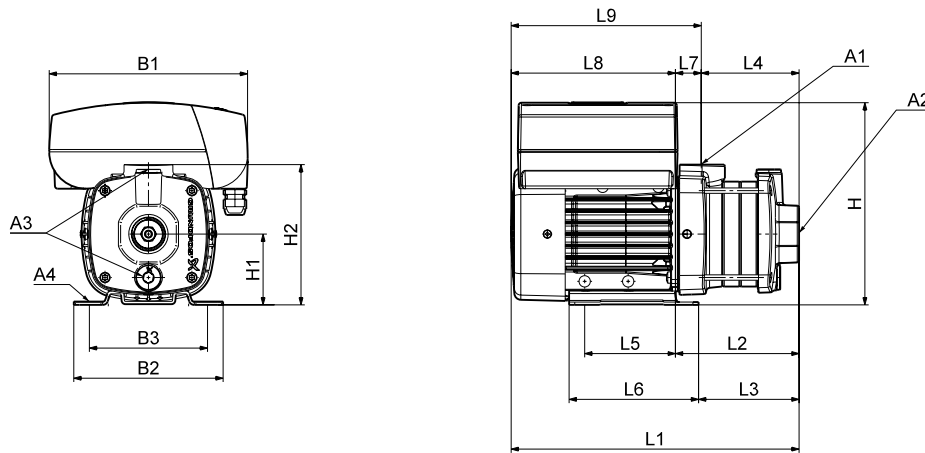

TM04 2249 2208

Dimensions

3 x 380-480 V, 50/60 Hz (supply voltage L)

Pump type	Frame size	P ₂ [kW]	Dimensions [mm]																		
			A1	A2	A3	A4	B1	B2	B3	H	H1	H2	L1	L2	L3	L4	L5	L6	L7	L8	L9
CME 15-1	90	2.20	2"	2"	3/8"	10	264	199	160	267	100	245	461	190	175	97	140	170	93	272	364
CME 15-2	112	5.50	2"	2"	3/8"	12	290	228	190	300	112	257	530	228	212	97	140	172	131	302	433
CME 15-3	132	7.50	2"	2"	3/8"	12	290	228	190	300	112	257	560	258	242	127	140	172	131	302	433

3 x 460-480 V, 60 Hz (supply voltage N)

Pump type	Frame size	P ₂ [kW]	Dimensions [mm]																		
			A1	A2	A3	A4	B1	B2	B3	H	H1	H2	L1	L2	L3	L4	L5	L6	L7	L8	L9
CME 15-1	90	2.20	2"	2"	3/8"	10	264	199	160	267	100	245	461	190	175	97	140	170	93	272	364
CME 15-2	112	4.00	2"	2"	3/8"	12	290	228	190	300	112	257	530	228	212	97	140	172	131	302	433
CME 15-3	132	5.50	2"	2"	3/8"	12	290	228	190	300	112	257	560	258	242	127	140	172	131	302	433

Dimensions, CME 60 Hz and 50/60 Hz

CME 15-I and CME 15-G
60 Hz
50/60 Hz

CME 15-I and CME 15-G

(I = EN 1.4301/AISI 304 and G = EN 1.4401/AISI 316)

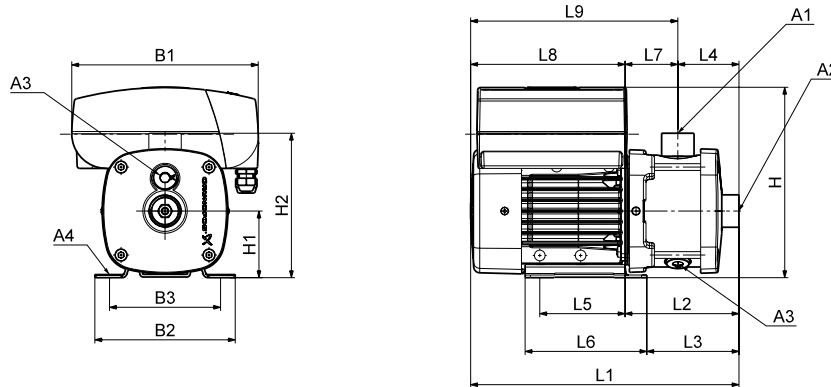

TM04 2247 2208

Dimensions

3 x 380-480 V, 50/60 Hz (supply voltage L)

Pump type	Frame size	P ₂ [kW]	Dimensions [mm]																		
			A1	A2	A3	A4	B1	B2	B3	H	H1	H2	L1	L2	L3	L4	L5	L6	L7	L8	L9
CME 15-1	90	2.20	2"	2"	3/8"	10	264	199	160	267	100	218	490	219	204	105	140	170	114	272	385
CME 15-2	112	5.50	2"	2"	3/8"	12	290	228	190	300	112	230	559	257	241	105	140	172	152	302	454
CME 15-3	132	7.50	2"	2"	3/8"	12	290	228	190	300	112	230	559	257	241	105	140	172	152	302	454

3 x 460-480 V, 60 Hz (supply voltage N)

Pump type	Frame size	P ₂ [kW]	Dimensions [mm]																		
			A1	A2	A3	A4	B1	B2	B3	H	H1	H2	L1	L2	L3	L4	L5	L6	L7	L8	L9
CME 15-1	90	2.20	2"	2"	3/8"	10	264	199	160	267	100	218	490	219	204	105	140	170	114	272	385
CME 15-2	112	4.00	2"	2"	3/8"	12	290	228	190	300	112	230	559	257	241	105	140	172	152	302	454
CME 15-3	132	5.50	2"	2"	3/8"	12	290	228	190	300	112	230	559	257	241	105	140	172	152	302	454

Dimensions, CME 60 Hz and 50/60 Hz

CME 25-A
60 Hz
50/60 Hz

CME 25-A

(A = cast iron, EN-GJL-200)

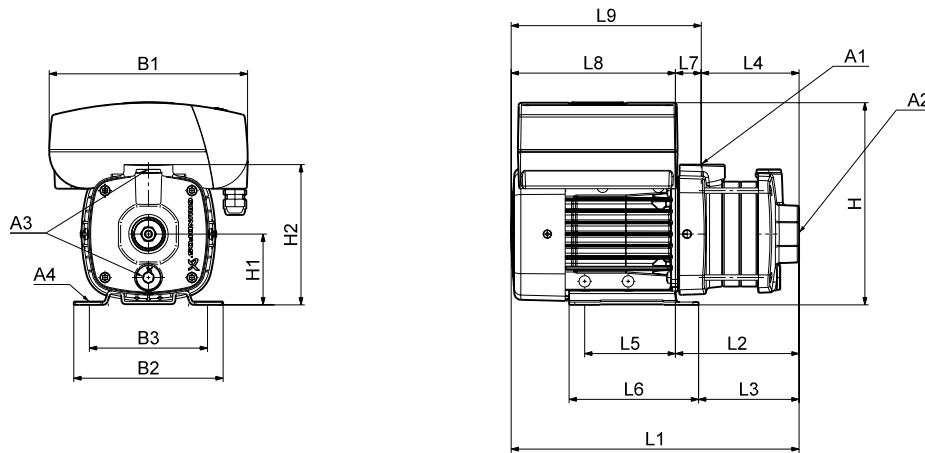

TM04 2249 2208

Dimensions

3 x 380-480 V, 50/60 Hz (supply voltage L)

Pump type	Frame size	P ₂ [kW]	Dimensions [mm]																		
			A1	A2	A3	A4	B1	B2	B3	H	H1	H2	L1	L2	L3	L4	L5	L6	L7	L8	L9
CME 25-1	100	3.00	2"	2"	3/8"	10	264	199	160	277	100	245	477	205	190	97	140	170	108	272	380
CME 25-2	132	7.50	2"	2"	3/8"	12	290	228	190	300	112	257	530	228	212	97	140	172	131	302	433

3 x 460-480 V, 60 Hz (supply voltage N)

Pump type	Frame size	P ₂ [kW]	Dimensions [mm]																		
			A1	A2	A3	A4	B1	B2	B3	H	H1	H2	L1	L2	L3	L4	L5	L6	L7	L8	L9
CME 25-1	112	4.00	2"	2"	3/8"	12	290	228	190	300	112	257	530	228	212	97	140	172	131	302	433
CME 25-2	112	5.50	2"	2"	3/8"	12	290	228	190	300	112	257	530	228	212	97	140	172	131	302	433

Dimensions, CME 60 Hz and 50/60 Hz

CME 25-I and CME 25-G
60 Hz
50/60 Hz

CME 25-I and CME 25-G

(I = EN 1.4301/AISI 304 and G = EN 1.4401/AISI 316)

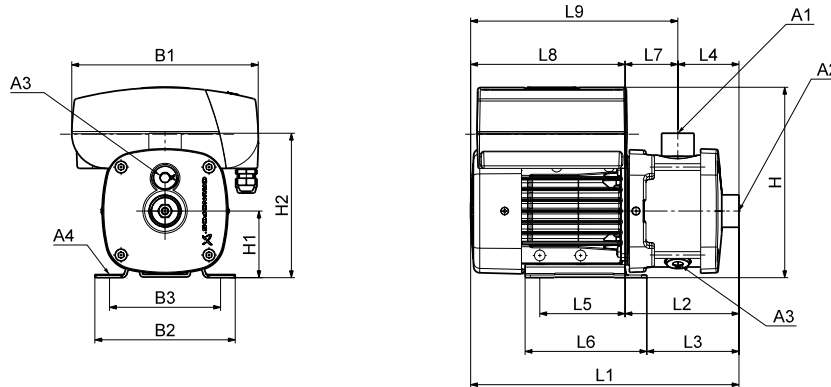

TM04 2247 2208

Dimensions

3 x 380-480 V, 50/60 Hz (supply voltage L)

Pump type	Frame size	P ₂ [kW]	Dimensions [mm]																		
			A1	A2	A3	A4	B1	B2	B3	H	H1	H2	L1	L2	L3	L4	L5	L6	L7	L8	L9
CME 25-1	100	3.00	2"	2"	3/8"	10	264	199	160	277	100	218	507	235	220	105	140	170	130	272	402
CME 25-2	132	7.50	2"	2"	3/8"	12	290	228	190	300	112	230	559	257	241	105	140	172	152	302	454

3 x 460-480 V, 60 Hz (supply voltage N)

Pump type	Frame size	P ₂ [kW]	Dimensions [mm]																		
			A1	A2	A3	A4	B1	B2	B3	H	H1	H2	L1	L2	L3	L4	L5	L6	L7	L8	L9
CME 25-1	112	4.00	2"	2"	3/8"	12	290	228	190	300	112	230	559	257	241	105	140	172	152	302	454
CME 25-2	112	5.50	2"	2"	3/8"	12	290	228	190	300	112	230	559	257	241	105	140	172	152	302	454

Weights and shipping volume

All weights and volumes refer to CM(E) pumps with standard pipe connections.

CM 1-A

(A = cast iron, EN-GJL-200)

Supply voltage	Pump type	Net weight [kg]	Gross weight [kg]	Shipping volume [m ³]
1 x 220-240 V, 50 Hz (supply voltage C)	CM 1-2	11.0	13.5	0.0296
	CM 1-3	11.3	13.8	0.0296
	CM 1-4	12.2	14.7	0.0370
	CM 1-5	12.5	15.0	0.0370
	CM 1-6	12.8	15.3	0.0370
	CM 1-7	13.0	15.5	0.0370
	CM 1-8	14.7	17.2	0.0444
	1 x 115/230 V, 60 Hz (supply voltage B)	CM 1-2	11.7	14.2
CM 1-3		12.0	14.5	0.0296
CM 1-4		12.2	14.7	0.0370
CM 1-5		12.5	15.0	0.0370
3 x 220-240 V / 380-415 V, 50 Hz (supply voltage F)	CM 1-2	11.0	13.5	0.0296
	CM 1-3	11.3	13.8	0.0296
	CM 1-4	11.5	14.0	0.0370
	CM 1-5	11.8	14.3	0.0370
	CM 1-6	12.1	14.6	0.0370
	CM 1-7	13.0	15.5	0.0370
	CM 1-8	13.3	15.8	0.0370
	3 x 200/346 V, 50 Hz; 3 x 200-220/346-380 V, 60 Hz (supply voltage G)	CM 1-2	11.0	13.5
CM 1-3		11.3	13.8	0.0296
CM 1-4		12.2	14.7	0.0370
CM 1-5		12.5	15.0	0.0370
3 x 208-230 V / 440-480 V, 60 Hz (supply voltage E)	CM 1-2	11.0	13.5	0.0296
	CM 1-3	11.3	13.8	0.0296
3 x 575 V, 60 Hz (supply voltage H)	CM 1-3	11.3	13.8	0.0296
3 x 400 V, 50/60 Hz (supply voltage I)	CM 1-4	12.2	14.7	0.0370
3 x 380-415 V, 50 Hz; 3 x 440-480 V, 60 Hz (supply voltage J)	CM 1-4	12.2	14.7	0.0370
3 x 220-240/380-415 V, 50 Hz; 3 x 220-255/380-440 V, 60 Hz (supply voltage O)	CM 1-5	12.5	15.0	0.0370

Weights and shipping volume

CM, CME

CM 3-A

(A = cast iron, EN-GJL-200)

Supply voltage	Pump type	Net weight [kg]	Gross weight [kg]	Shipping volume [m ³]
1 x 220-240 V, 50 Hz (supply voltage C)	CM 3-2	11.0	13.5	0.0296
	CM 3-3	12.0	14.5	0.0296
	CM 3-4	12.2	14.7	0.0370
	CM 3-5	12.5	15.0	0.0370
	CM 3-6	14.2	16.7	0.0370
	CM 3-7	15.5	18.0	0.0370
1 x 115/230 V, 60 Hz (supply voltage B) 1 x 220 V, 60 Hz (supply voltage A)	CM 3-8	15.8	18.3	0.0444
	CM 3-2	11.7	14.2	0.0296
	CM 3-3	12.0	14.5	0.0296
	CM 3-4	13.6	16.1	0.0370
3 x 220-240 V / 380-415 V, 50 Hz (supply voltage F)	CM 3-5	12.5	15.0	0.0370
	CM 3-2	11.0	13.5	0.0296
	CM 3-3	11.3	13.8	0.0296
	CM 3-4	11.5	14.0	0.0370
	CM 3-5	12.5	15.0	0.0370
	CM 3-6	12.8	15.3	0.0370
3 x 200/346 V, 50 Hz; 3 x 200-220/346-380 V, 60 Hz (supply voltage G)	CM 3-7	14.4	16.9	0.0370
	CM 3-8	15.8	18.3	0.0444
	CM 3-2	11.0	13.5	0.0296
	CM 3-3	12.0	14.5	0.0296
3 x 208-230 V / 440-480 V, 60 Hz (supply voltage E) 3 x 575 V, 60 Hz (supply voltage H) 3 x 400 V, 50/60 Hz (supply voltage I)	CM 3-4	12.2	14.7	0.0370
	CM 3-5	13.9	16.4	0.0370
	CM 3-2	11.0	13.5	0.0296
3 x 380-415 V, 50 Hz; 3 x 440-480 V, 60 Hz (supply voltage J) 3 x 220-240/380-415 V, 50 Hz; 3 x 220-255/380-440 V, 60 Hz (supply voltage O)	CM 3-3	12.0	14.5	0.0296
	CM 3-4	12.2	14.7	0.0370
	CM 3-5	13.9	16.4	0.0370

Weights and shipping volume

CM, CME

CM 5-A

(A = cast iron, EN-GJL-200)

Supply voltage	Pump type	Net weight [kg]	Gross weight [kg]	Shipping volume [m ³]
1 x 220-240 V, 50 Hz (supply voltage C)	CM 5-2	2.9	5.4	0.0296
	CM 5-3	3.2	5.7	0.0296
	CM 5-4	3.4	5.9	0.0370
	CM 5-5	3.7	6.2	0.0370
	CM 5-6	23.0	25.5	0.0444
	CM 5-7	23.3	25.8	0.0444
	CM 5-8	23.5	26.0	0.0444
	1 x 115/230 V, 60 Hz (supply voltage B) 1 x 220 V, 60 Hz (supply voltage A)	CM 5-2	13.0	15.5
CM 5-3		14.4	16.9	0.0370
CM 5-4		24.3	26.8	0.0370
3 x 220-240 V / 380-415 V, 50 Hz (supply voltage F)	CM 5-2	10.9	13.4	0.0296
	CM 5-3	11.9	14.4	0.0296
	CM 5-4	13.5	16.0	0.0370
	CM 5-5	14.9	17.4	0.0370
	CM 5-6	15.2	17.7	0.0370
	CM 5-7	23.3	25.8	0.0444
	CM 5-8	23.5	26.0	0.0444
3 x 200/346 V, 50 Hz; 3 x 200-220/346-380 V, 60 Hz (supply voltage G)	CM 5-2	11.6	14.1	0.0296
	CM 5-3	13.3	15.8	0.0370
	CM 5-4	24.3	26.8	0.0370
3 x 208-230 V / 440-480 V, 60 Hz (supply voltage E) 3 x 575 V, 60 Hz (supply voltage H) 3 x 400 V, 50/60 Hz (supply voltage I) 3 x 380-415 V, 50 Hz; 3 x 440-480 V, 60 Hz (supply voltage J) 3 x 220-240/380-415 V, 50 Hz; 3 x 220-255/380-440 V, 60 Hz (supply voltage O)	CM 5-5	24.5	27.0	0.0444
	CM 5-2	11.6	14.1	0.0296
	CM 5-3	13.3	15.8	0.0370
	CM 5-4	24.3	26.8	0.0370
CM 5-5	24.5	27.0	0.0444	

CM 10-A

(A = cast iron, EN-GJL-200)

Supply voltage	Pump type	Net weight [kg]	Gross weight [kg]	Shipping volume [m ³]
1 x 220-240 V, 50 Hz (supply voltage C)	CM 10-1	22.2	24.7	0.0370
	CM 10-2	29.8	32.3	0.0444
	CM 10-3	32.6	35.1	0.0444
1 x 115/230 V, 60 Hz (supply voltage B) 1 x 220 V, 60 Hz (supply voltage A)	CM 10-1	23.4	25.9	0.0370
	CM 10-1	20.9	23.4	0.0370
3 x 220-240 V / 380-415 V, 50 Hz (supply voltage F)	CM 10-2	24.0	26.5	0.0370
	CM 10-3	32.6	35.1	0.0444
	CM 10-4	38.6	41.1	0.0495
	CM 10-5	39.3	41.8	0.0495
	CM 10-11	23.4	25.9	0.0370
3 x 200/346 V, 50 Hz; 3 x 200-220 / 346-380 V, 60 Hz (supply voltage G)	CM 10-12	31.9	34.4	0.0444
	CM 10-13	40.8	43.3	0.0444
	CM 10-1	23.4	25.9	0.0370
3 x 208-230 V / 440-480 V, 60 Hz (supply voltage E) 3 x 575 V, 60 Hz (supply voltage H) 3 x 400 V, 50/60 Hz (supply voltage I) 3 x 380-415 V, 50 Hz; 3 x 440-480 V, 60 Hz (supply voltage J) 3 x 220-240/380-415 V, 50 Hz; 3 x 220-255/380-440 V, 60 Hz (supply voltage O)	CM 10-2	31.9	34.4	0.0444
	CM 10-3	40.8	43.3	0.0444
	CM 10-1	23.4	25.9	0.0370
	CM 10-3	40.8	43.3	0.0444

CM 15-A

(A = cast iron, EN-GJL-200)

Supply voltage	Pump type	Net weight [kg]	Gross weight [kg]	Shipping volume [m ³]
1 x 220-240 V, 50 Hz (supply voltage C)	CM 15-1	24.5	27.0	0.0444
	CM 15-2	26.8	29.3	0.0444
3 x 220-240 V / 380-415 V, 50 Hz (supply voltage F)	CM 15-1	18.6	21.1	0.0370
	CM 15-2	26.8	29.3	0.0444
	CM 15-3	35.2	37.7	0.0444
	CM 15-4	51.2	53.7	0.0495
3 x 200/346 V, 50 Hz; 3 x 200-220/346-380 V, 60 Hz (supply voltage G)	CM 15-1	26.6	29.08	0.0444
	CM 15-2	35.0	37.46	0.0444
	CM 15-3	43.3	45.82	0.0495
3 x 208-230 V / 440-480 V, 60 Hz (supply voltage E)	CM 15-1	26.6	29.1	0.0444
3 x 575 V, 60 Hz (supply voltage H)	CM 15-2	35.0	37.5	0.0444
3 x 400 V, 50/60 Hz (supply voltage I)	CM 15-3	43.3	45.8	0.0495
3 x 380-415 V, 50 Hz; 3 x 440-480 V, 60 Hz (supply voltage J)				
3 x 220-240/380-415 V, 50 Hz; 3 x 220-255/380-440 V, 60 Hz (supply voltage O)				

CM 25-A

(A = cast iron, EN-GJL-200)

Supply voltage	Pump type	Net weight [kg]	Gross weight [kg]	Shipping volume [m ³]
1 x 220-240 V, 50 Hz (supply voltage C)	CM 25-1	28.5	31.0	0.0370
	CM 25-1	30.6	33.1	0.0370
3 x 220-240 V / 380-415 V, 50 Hz (supply voltage F)	CM 25-2	39.5	42.0	0.0444
	CM 25-3	55.3	57.8	0.0495
	CM 25-4	56.0	58.5	0.0495
	CM 25-1	38.8	41.31	0.0444
3 x 200/346 V, 50 Hz; 3 x 200-220/346-380 V, 60 Hz (supply voltage G)	CM 25-2	47.6	50.11	0.0495
	CM 25-1	38.8	41.3	0.0444
3 x 208-230 V / 440-480 V, 60 Hz (supply voltage E)	CM 25-2	47.6	50.1	0.0495
3 x 575 V, 60 Hz (supply voltage H)				
3 x 400 V, 50/60 Hz (supply voltage I)				
3 x 380-415 V, 50 Hz; 3 x 440-480 V, 60 Hz (supply voltage J)				
3 x 220-240/380-415 V, 50 Hz; 3 x 220-255/380-440 V, 60 Hz (supply voltage O)				

Weights and shipping volume

CM, CME

CM 1-I and CM 1-G

(I = EN 1.4301/AISI 304 and G = EN 1.4401/AISI 316)

Supply voltage	Pump type	Net weight [kg]	Gross weight [kg]	Shipping volume [m ³]
1 x 220-240 V, 50 Hz (supply voltage C)	CM 1-2	11.6	14.1	0.0296
	CM 1-3	11.7	14.2	0.0296
	CM 1-4	12.7	15.2	0.0370
	CM 1-5	13.1	15.6	0.0370
	CM 1-6	13.7	16.2	0.0370
	CM 1-7	13.7	16.2	0.0370
	CM 1-8	15.7	18.2	0.0444
	CM 1-9	15.8	18.3	0.0444
	CM 1-10	16.4	18.9	0.0444
	CM 1-11	17.6	20.1	0.0444
	CM 1-12	18.5	21.0	0.0495
	CM 1-13	18.6	21.1	0.0495
	CM 1-14	24.3	26.8	0.0495
	1 x 115/230 V, 60 Hz (supply voltage B) 1 x 220 V, 60 Hz (supply voltage A)	CM 1-2	12.3	14.8
CM 1-3		12.4	14.9	0.0296
CM 1-4		12.7	15.2	0.0370
CM 1-5		13.1	15.6	0.0370
CM 1-6		15.1	17.6	0.0370
CM 1-7		16.2	18.7	0.0370
CM 1-8		16.8	19.3	0.0444
3 x 220-240 V / 380-415 V, 50 Hz (supply voltage J)	CM 1-2	11.6	14.1	0.0296
	CM 1-3	11.7	14.2	0.0296
	CM 1-4	12.0	14.5	0.0370
	CM 1-5	12.4	14.9	0.0370
	CM 1-6	13.0	15.5	0.0370
	CM 1-7	13.7	16.2	0.0370
	CM 1-8	14.3	16.8	0.0370
	CM 1-9	14.4	16.9	0.0370
	CM 1-10	16.4	18.9	0.0444
	CM 1-11	16.5	19.0	0.0444
	CM 1-12	17.4	19.9	0.0495
	CM 1-13	18.6	21.1	0.0495
	CM 1-14	18.6	21.1	0.0495
	3 x 200/346 V, 50 Hz; 3 x 200-220/346-380 V, 60 Hz (supply voltage G)	CM 1-2	11.6	14.1
CM 1-3		11.7	14.2	0.0296
CM 1-4		12.7	15.2	0.0370
CM 1-5		13.1	15.6	0.0370
CM 1-6		13.7	16.2	0.0370
CM 1-7		13.7	16.2	0.0370
CM 1-8		15.7	18.2	0.0444
CM 1-9		16.9	19.4	0.0444
3 x 208-230 V / 440-480 V, 60 Hz (supply voltage E) 3 x 575 V, 60 Hz (supply voltage H) 3 x 400 V, 50/60 Hz (supply voltage I) 3 x 380-415 V, 50 Hz; 3 x 440-480 V, 60 Hz (supply voltage J) 3 x 220-240/380-415 V, 50 Hz; 3 x 220-255/380-440 V, 60 Hz (supply voltage O)		CM 1-2	11.6	14.1
	CM 1-3	11.7	14.2	0.0296
	CM 1-4	12.7	15.2	0.0370
	CM 1-5	13.1	15.6	0.0370
	CM 1-6	13.7	16.2	0.0370
	CM 1-7	13.7	16.2	0.0370
	CM 1-8	15.7	18.2	0.0444
	CM 1-9	16.9	19.4	0.0444

Weights and shipping volume

CM, CME

CM 3-I and CM 3-G

(I = EN 1.4301/AISI 304 and G = EN 1.4401/AISI 316)

Supply voltage	Pump type	Net weight [kg]	Gross weight [kg]	Shipping volume [m ³]
1 x 220-240 V, 50 Hz (supply voltage C)	CM 3-2	11.6	14.1	0.0296
	CM 3-3	12.4	14.9	0.0296
	CM 3-4	12.7	15.2	0.0370
	CM 3-5	13.1	15.6	0.0370
	CM 3-6	16.2	18.7	0.0370
	CM 3-7	16.2	18.7	0.0370
	CM 3-8	16.8	19.3	0.0444
	CM 3-9	22.6	25.1	0.0444
	CM 3-10	23.2	25.7	0.0495
	CM 3-11	23.3	25.8	0.0495
	CM 3-12	24.2	26.7	0.0495
	CM 3-13	24.2	26.7	0.0495
	CM 3-14	26.4	28.9	0.0495
	1 x 115/230 V, 60 Hz (supply voltage B) 1 x 220 V, 60 Hz (supply voltage A)	CM 3-2	12.3	14.8
CM 3-3		12.4	14.9	0.0296
CM 3-4		14.1	16.6	0.0370
CM 3-5		15.6	18.1	0.0370
CM 3-6		23.8	26.3	0.0444
CM 3-7		24.0	26.5	0.0444
CM 3-8		24.6	27.1	0.0444
3 x 220-240 V / 380-415 V, 50 Hz (supply voltage F)	CM 3-2	11.6	14.1	0.0296
	CM 3-3	11.7	14.2	0.0296
	CM 3-4	12.0	14.5	0.0370
	CM 3-5	13.1	15.6	0.0370
	CM 3-6	13.7	16.2	0.0370
	CM 3-7	15.1	17.6	0.0370
	CM 3-8	16.8	19.3	0.0444
	CM 3-9	16.9	19.4	0.0444
	CM 3-10	17.5	20.0	0.0444
	CM 3-11	23.3	25.8	0.0495
	CM 3-12	24.2	26.7	0.0495
	CM 3-13	24.2	26.7	0.0495
	CM 3-14	26.4	28.9	0.0495
	3 x 200/346 V, 50 Hz; 3 x 200-220/346-380 V, 60 Hz (supply voltage G)	CM 3-2	11.6	14.1
CM 3-3		12.4	14.9	0.0296
CM 3-4		12.7	15.2	0.0370
CM 3-5		14.5	17.0	0.0370
CM 3-6		16.2	18.7	0.0370
CM 3-7		24.0	26.5	0.0444
CM 3-8		24.6	27.1	0.0444
CM 3-9		24.7	27.2	0.0444
3 x 208-230 V / 440-480 V, 60 Hz (supply voltage E) 3 x 575 V, 60 Hz (supply voltage H) 3 x 400 V, 50/60 Hz (supply voltage I) 3 x 380-415 V, 50 Hz; 3 x 440-480 V, 60 Hz (supply voltage J) 3 x 220-240/380-415 V, 50 Hz; 3 x 220-255/380-440 V, 60 Hz (supply voltage O)		CM 3-2	11.6	14.1
	CM 3-3	12.4	14.9	0.0296
	CM 3-4	12.7	15.2	0.0370
	CM 3-5	14.5	17.0	0.0370
	CM 3-6	16.2	18.7	0.0370
	CM 3-7	24.0	26.5	0.0444
	CM 3-8	24.6	27.1	0.0444
	CM 3-9	24.7	27.2	0.0444
	CM 3-9	24.7	27.2	0.0444

Weights and shipping volume

CM, CME

CM 5-I and CM 5-G

(I = EN 1.4301/AISI 304 and G = EN 1.4401/AISI 316)

Supply voltage	Pump type	Net weight [kg]	Gross weight [kg]	Shipping volume [m ³]
1 x 220-240 V, 50 Hz (supply voltage C)	CM 5-2	12.3	14.8	0.0296
	CM 5-3	12.4	14.9	0.0296
	CM 5-4	14.1	16.6	0.0370
	CM 5-5	15.5	18.0	0.0370
	CM 5-6	21.8	24.3	0.0444
	CM 5-7	21.9	24.4	0.0444
	CM 5-8	22.5	25.0	0.0444
	CM 5-9	24.7	27.2	0.0444
	CM 5-10	25.3	27.8	0.0495
	CM 5-11	25.4	27.9	0.0495
	1 x 115/230 V, 60 Hz (supply voltage B) 1 x 220 V, 60 Hz (supply voltage A)	CM 5-2	13.7	16.2
CM 5-3		14.9	17.4	0.0370
CM 5-4		23.0	25.5	0.0370
3 x 220-240 V / 380-415 V, 50 Hz (supply voltage F)	CM 5-2	11.6	14.1	0.0296
	CM 5-3	12.4	14.9	0.0296
	CM 5-4	14.1	16.6	0.0370
	CM 5-5	15.5	18.0	0.0370
	CM 5-6	16.1	18.6	0.0370
	CM 5-7	21.9	24.4	0.0444
	CM 5-8	22.5	25.0	0.0444
	CM 5-9	24.7	27.2	0.0444
	CM 5-10	25.3	27.8	0.0495
	CM 5-11	25.4	27.9	0.0495
	CM 5-12	26.2	28.7	0.0495
	CM 5-13	31.6	34.1	0.0847
	3 x 200/346 V, 50 Hz; 3 x 200-220/346-380 V, 60 Hz (supply voltage G)	CM 5-2	12.3	14.8
CM 5-3		13.8	16.3	0.0370
CM 5-4		23.0	25.5	0.0370
CM 5-5		23.3	25.8	0.0444
CM 5-6		23.9	26.4	0.0444
CM 5-7		24.0	26.5	0.0444
CM 5-8		32.8	35.3	0.0495
CM 5-2		12.3	14.8	0.0296
3 x 208-230 V / 440-480 V, 60 Hz (supply voltage E) 3 x 575 V, 60 Hz (supply voltage H) 3 x 400 V, 50/60 Hz (supply voltage I) 3 x 380-415 V, 50 Hz; 3 x 440-480 V, 60 Hz (supply voltage J) 3 x 220-240/380-415 V, 50 Hz; 3 x 220-255/380-440 V, 60 Hz (supply voltage O)	CM 5-3	13.8	16.3	0.0370
	CM 5-4	23.0	25.5	0.0370
	CM 5-5	23.3	25.8	0.0444
	CM 5-6	23.9	26.4	0.0444
	CM 5-7	24.0	26.5	0.0444
	CM 5-8	32.8	35.3	0.0495

CM 10-I and CM 10-G

(I = EN 1.4301/AISI 304 and G = EN 1.4401/AISI 316)

Supply voltage	Pump type	Net weight [kg]	Gross weight [kg]	Shipping volume [m ³]
1 x 220-240 V, 50 Hz (supply voltage C)	CM 10-1	17.6	20.1	0.0370
	CM 10-2	24.8	27.3	0.0444
	CM 10-3	27.1	29.6	0.0444
1 x 115/230 V, 60 Hz (supply voltage B) 1 x 220 V, 60 Hz (supply voltage A) 3 x 220-240 V / 380-415 V, 50 Hz (supply voltage F)	CM 10-1	18.8	21.3	0.0370
	CM 10-1	16.3	18.8	0.0370
	CM 10-2	19.0	21.5	0.0370
	CM 10-3	27.1	29.6	0.0444
	CM 10-4	33.2	35.7	0.0495
	CM 10-5	34.6	37.1	0.0847
	CM 10-6	37.7	40.2	0.0847
	CM 10-7	54.3	56.8	0.0847
3 x 200/346 V, 50 Hz; 3 x 200-220/346-380 V, 60 Hz (supply voltage G)	CM 10-8	54.5	57.0	0.0847
	CM 10-1	18.8	21.3	0.0370
	CM 10-2	26.9	29.4	0.0444
	CM 10-3	35.3	37.8	0.0444
	CM 10-4	44.3	46.8	0.0495
3 x 208-230 V / 440-480 V, 60 Hz (supply voltage E) 3 x 575 V, 60 Hz (supply voltage H) 3 x 400 V, 50/60 Hz (supply voltage I) 3 x 380-415 V, 50 Hz; 3 x 440-480 V, 60 Hz (supply voltage J) 3 x 220-240/380-415 V, 50 Hz; 3 x 220-255/380-440 V, 60 Hz (supply voltage O)	CM 10-5	45.7	48.2	0.0847
	CM 10-1	18.8	21.3	0.0370
	CM 10-2	26.9	29.4	0.0444
	CM 10-3	35.3	37.8	0.0444
	CM 10-4	44.3	46.8	0.0495
CM 10-5	45.7	48.2	0.0847	

CM 15-I and CM 15-G

(I = EN 1.4301/AISI 304 and G = EN 1.4401/AISI 316)

Supply voltage	Pump type	Net weight [kg]	Gross weight [kg]	Shipping volume [m ³]
1 x 220-240 V, 50 Hz (supply voltage C)	CM 15-1	24.5	27.0	0.0444
	CM 15-2	26.8	29.3	0.0444
	CM 15-1	18.6	21.1	0.0370
3 x 220-240 V / 380-415 V, 50 Hz (supply voltage F)	CM 15-2	26.8	29.3	0.0444
	CM 15-3	35.2	37.7	0.0444
	CM 15-4	51.2	53.7	0.0495
3 x 200/346 V, 50 Hz; 3 x 200-220/346-380 V, 60 Hz (supply voltage G)	CM 15-1	26.6	29.08	0.0444
	CM 15-2	35.0	37.46	0.0444
	CM 15-3	43.3	45.82	0.0495
3 x 208-230 V / 440-480 V, 60 Hz (supply voltage E) 3 x 575 V, 60 Hz (supply voltage H) 3 x 400 V, 50/60 Hz (supply voltage I) 3 x 380-415 V, 50 Hz; 3 x 440-480 V, 60 Hz (supply voltage J) 3 x 220-240/380-415 V, 50 Hz; 3 x 220-255/380-440 V, 60 Hz (supply voltage O)	CM 15-1	26.6	29.1	0.0444
	CM 15-2	35.0	37.5	0.0444
	CM 15-3	43.3	45.8	0.0495
	CM 15-3	43.3	45.8	0.0495

CM 25-I and CM 25-G

(I = EN 1.4301/AISI 304 and G = EN 1.4401/AISI 316)

Supply voltage	Pump type	Net weight [kg]	Gross weight [kg]	Shipping volume [m ³]
1 x 220-240 V, 50 Hz (supply voltage C)	CM 25-1	24.5	27.0	0.0444
	CM 25-2	26.8	29.3	0.0444
3 x 220-240 V / 380-415 V, 50 Hz (supply voltage F)	CM 25-1	18.6	21.1	0.0370
	CM 25-2	26.8	29.3	0.0444
	CM 25-3	35.2	37.7	0.0444
	CM 25-4	51.2	53.7	0.0495
3 x 200/346 V, 50 Hz; 3 x 200-220/346-380 V, 60 Hz (supply voltage G)	CM 25-1	26.6	29.08	0.0444
	CM 25-2	35.0	37.46	0.0444
	CM 25-3	43.3	45.82	0.0495
3 x 208-230 V / 440-480 V, 60 Hz (supply voltage E) 3 x 575 V, 60 Hz (supply voltage H) 3 x 400 V, 50/60 Hz (supply voltage I) 3 x 380-415 V, 50 Hz; 3 x 440-480 V, 60 Hz (supply voltage J) 3 x 220-240/380-415 V, 50 Hz; 3 x 220-255/380-440 V, 60 Hz (supply voltage O)	CM 25-1	26.6	29.1	0.0444
	CM 25-2	35.0	37.5	0.0444
	CM 25-3	43.3	45.8	0.0495
	CM 25-3	43.3	45.8	0.0495

CME 1-A

(A = cast iron, EN-GJL-200)

Supply voltage	Pump type	Net weight [kg]	Gross weight [kg]	Shipping volume [m ³]
1 x 220-240 V, 50/60 Hz (supply voltage K) 1 x 208-230 V, 50/60 Hz (supply voltage M)	CME 1-2	14.4	17.9	0.0296
	CME 1-3	14.7	18.2	0.0296
	CME 1-4	14.9	18.4	0.0370
	CME 1-5	17.6	21.1	0.0370
	CME 1-5	17.6	21.1	0.0370

CME 3-A

(A = cast iron, EN-GJL-200)

Supply voltage	Pump type	Net weight [kg]	Gross weight [kg]	Shipping volume [m ³]
1 x 220-240 V, 50/60 Hz (supply voltage K) 1 x 208-230 V, 50/60 Hz (supply voltage M)	CME 3-2	14.4	17.9	0.0296
	CME 3-3	17.1	20.6	0.0370
	CME 3-4	17.3	20.8	0.0370
	CME 3-5	17.6	21.1	0.0370
	CME 3-5	17.6	21.1	0.0370

CME 5-A

(A = cast iron, EN-GJL-200)

Supply voltage	Pump type	Net weight [kg]	Gross weight [kg]	Shipping volume [m ³]
1 x 220-240 V, 50/60 Hz (supply voltage K) 1 x 208-230 V, 50/60 Hz (supply voltage M)	CME 5-2	16.7	20.2	0.0296
	CME 5-3	17.0	20.5	0.0370
3 x 380-480 V, 50/60 Hz (supply voltage L)	CME 5-4	30.0	33.5	0.0847
	CME 5-5	34.2	37.7	0.0847
3 x 460-480 V, 60 Hz (supply voltage N)	CME 5-4	31.3	34.8	0.0847
	CME 5-5	31.5	35.0	0.0847

CME 10-A

(A = cast iron, EN-GJL-200)

Supply voltage	Pump type	Net weight [kg]	Gross weight [kg]	Shipping volume [m ³]
1 x 220-240 V, 50/60 Hz (supply voltage K) 1 x 208-230 V, 50/60 Hz (supply voltage M)	CME 10-1	25.9	29.4	0.0370
	CME 10-2	41.6	45.1	0.0847
3 x 380-480 V, 50/60 Hz (supply voltage L)	CME 10-3	63.5	67.0	0.0847
	CME 10-2	41.7	45.2	0.0847
3 x 460-480 V, 60 Hz (supply voltage N)	CME 10-3	60.2	63.7	0.0847

CME 15-A

(A = cast iron, EN-GJL-200)

Supply voltage	Pump type	Net weight [kg]	Gross weight [kg]	Shipping volume [m ³]
3 x 380-480 V, 50/60 Hz (supply voltage L)	CME 15-1	36.3	39.8	0.0847
	CME 15-2	57.6	61.1	0.0847
	CME 15-3	62.0	65.5	0.0847
3 x 460-480 V, 60 Hz (supply voltage N)	CME 15-1	36.4	39.9	0.0847
	CME 15-2	54.3	57.8	0.0847
	CME 15-3	58.2	61.7	0.0847

CME 25-A

(A = cast iron, EN-GJL-200)

Supply voltage	Pump type	Net weight [kg]	Gross weight [kg]	Shipping volume [m ³]
3 x 380-480 V, 50/60 Hz (supply voltage L)	CME 25-1	39.5	43.0	0.0847
	CME 25-2	61.8	65.3	0.0847
3 x 460-480 V, 60 Hz (supply voltage N)	CME 25-1	54.1	57.6	0.0847
	CME 25-2	58.0	61.5	0.0847

CME 1-I and CME 1-G

(I = EN 1.4301/AISI 304 and G = EN 1.4401/AISI 316)

Supply voltage	Pump type	Net weight [kg]	Gross weight [kg]	Shipping volume [m ³]
1 x 220-240 V, 50/60 Hz (supply voltage K) 1 x 208-230 V, 50/60 Hz (supply voltage M)	CME 1-2	15.0	18.5	0.0296
	CME 1-3	15.1	18.6	0.0296
	CME 1-4	15.4	18.9	0.0370
	CME 1-5	18.2	21.7	0.0370
	CME 1-6	18.8	22.3	0.0370
	CME 1-7	18.8	22.3	0.0370
	CME 1-8	19.4	22.9	0.0444
	CME 1-9	30.4	33.9	0.0444
3 x 380-480 V, 50/60 Hz (supply voltage L)	CME 1-9	30.4	33.9	0.0444
3 x 460-480 V, 60 Hz (supply voltage N)	CME 1-9	31.7	35.2	0.0847

Weights and shipping volume

CM, CME

CME 3-I and CME 3-G

(I = EN 1.4301/AISI 304 and G = EN 1.4401/AISI 316)

Supply voltage	Pump type	Net weight [kg]	Gross weight [kg]	Shipping volume [m ³]
1 x 220-240 V, 50/60 Hz (supply voltage K) 1 x 208-230 V, 50/60 Hz (supply voltage M)	CME 3-2	15.0	18.5	0.0296
	CME 3-3	17.5	21.0	0.0370
	CME 3-4	17.8	21.3	0.0370
	CME 3-5	18.2	21.7	0.0370
3 x 380-480 V, 50/60 Hz (supply voltage L)	CME 3-6	29.7	33.2	0.0847
	CME 3-7	29.7	33.2	0.0847
	CME 3-8	34.3	37.8	0.0847
3 x 460-480 V, 60 Hz (supply voltage N)	CME 3-9	34.4	37.9	0.0847
	CME 3-6	31.0	34.5	0.0847
	CME 3-7	31.0	34.5	0.0847
	CME 3-8	31.6	35.1	0.0847
	CME 3-9	34.6	38.1	0.0847

CME 5-I and CME 5-G

(I = EN 1.4301/AISI 304 and G = EN 1.4401/AISI 316)

Supply voltage	Pump type	Net weight [kg]	Gross weight [kg]	Shipping volume [m ³]
1 x 220-240 V, 50/60 Hz (supply voltage K) 1 x 208-230 V, 50/60 Hz (supply voltage M)	CME 5-2	17.4	20.9	0.0370
	CME 5-3	17.5	21.0	0.0370
	CME 5-4	28.7	32.2	0.0370
	CME 5-5	33.0	36.5	0.0444
3 x 380-480 V, 50/60 Hz (supply voltage L)	CME 5-6	33.6	37.1	0.0444
	CME 5-7	36.9	40.4	0.0495
	CME 5-8	37.5	41.0	0.0495
	CME 5-4	30.0	33.5	0.0847
3 x 460-480 V, 60 Hz (supply voltage N)	CME 5-5	30.3	33.8	0.0847
	CME 5-6	33.8	37.3	0.0847
	CME 5-7	33.9	37.4	0.0847

CME 10-I and CME 10-G

(I = EN 1.4301/AISI 304 and G = EN 1.4401/AISI 316)

Supply voltage	Pump type	Net weight [kg]	Gross weight [kg]	Shipping volume [m ³]
1 x 220-240 V, 50/60 Hz (supply voltage K) 1 x 208-230 V, 50/60 Hz (supply voltage M)	CME 10-1	21.3	24.8	0.0370
	CME 10-2	36.6	40.1	0.0847
3 x 380-480 V, 50/60 Hz (supply voltage L)	CME 10-3	57.9	61.4	0.0847
	CME 10-4	58.8	62.3	0.0847
	CME 10-5	60.2	63.7	0.0847
	CME 10-2	36.7	40.2	0.0847
3 x 460-480 V, 60 Hz (supply voltage N)	CME 10-3	54.6	58.1	0.0847
	CME 10-4	55.5	59.0	0.0847
	CME 10-5	60.6	64.1	0.0847

CME 15-I and CME 15-G

(I = EN 1.4301/AISI 304 and G = EN 1.4401/AISI 316)

Supply voltage	Pump type	Net weight [kg]	Gross weight [kg]	Shipping volume [m ³]
3 x 380-480 V, 50/60 Hz (supply voltage L)	CME 15-1	36.3	39.8	0.0847
	CME 15-2	57.6	61.1	0.0847
	CME 15-3	62.0	65.5	0.0847
3 x 460-480 V, 60 Hz (supply voltage N)	CME 15-1	36.4	39.9	0.0847
	CME 15-2	54.3	57.8	0.0847
	CME 15-3	58.2	61.7	0.0847

CME 25-I and CME 25-G

(I = EN 1.4301/AISI 304 and G = EN 1.4401/AISI 316)

Supply voltage	Pump type	Net weight [kg]	Gross weight [kg]	Shipping volume [m ³]
3 x 380-480 V, 50/60 Hz (supply voltage L)	CME 25-1	39.5	43.0	0.0847
	CME 25-2	61.8	65.3	0.0847
3 x 460-480 V, 60 Hz (supply voltage N)	CME 25-1	54.1	57.6	0.0847
	CME 25-2	58.0	61.5	0.0847

Mains-operated motors, 50 Hz

1 x 220-240 V, 50 Hz (supply voltage C)

Frame size	P ₂ [kW]	I _{1/1} [A]	Cos φ _{1/1}	I _{start}	Speed [min ⁻¹]
71	0.30	2.2 - 2.5	0.95 - 0.86	7.5 - 8.5	2800-2830
71	0.50	3.4 - 3.0	0.97 - 0.99	18.0 - 15.9	2730-2740
80	0.67	4.4 - 4.0	0.99 - 0.99	17.2 - 15.6	2720-2800
80	0.90	5.0 - 5.4	0.98 - 0.98	21.5 - 23.3	2750-2790
90	1.30	8.4 - 9.4	0.98 - 0.98	28.6 - 32.0	2710-2710
90	1.70	11.0 - 11.8	0.99 - 0.98	40.7 - 43.7	2755-2770

3 x 220-240 V / 380-415 V, 50 Hz (supply voltage F)

Frame size	P ₂ [kW]	I _{1/1} [A]	Cos φ _{1/1}	I _{start}	Speed [min ⁻¹]
71	0.45	2.2 - 2.0 / 1.2 - 1.0	0.83 - 0.75	10.8 - 10.6 / 5.9 - 5.3	2770-2820
71	0.65	2.8 - 3.1 / 1.66 - 1.76	0.82 - 0.72	16.2 - 19.2 / 9.6 - 10.9	2800-2820
80	0.84	4.05 - 3.3 / 2.10 - 1.9	0.86 - 0.78	23.5 - 20.5 / 12.2 - 11.8	2750-2810
80	1.20	4.8 - 5.25 / 2.80 - 3.1	0.82 - 0.71	27.8 - 33.1 / 16.2 - 19.5	2800-2840
90	1.58	6.2 - 5.90 / 3.50 - 3.3	0.88 - 0.80	39.1 - 40.7 / 22.1 - 22.8	2840-2880
90	2.20	8.95 - 8.20 / 5.15 - 4.7	0.90 - 0.84	62.7 - 62.3 / 36.1 - 35.7	2830-2880
100	3.20	11.8 - 11.0 / 6.75 - 6.4	0.87 - 0.79	94.4 - 96.8 / 54.0 - 56.3	2900-2920
100	4.00	14.0 - 13.2 / 8.20 - 7.8	0.87 - 0.84	119.0 - 125.4 / 69.7 - 74.1	2900-2920
132	5.80	20.4 - 19.0 / 11.8 - 11.0	0.89 - 0.84	181.6 - 184.3 / 105.0 - 106.7	2900-2980
132	7.40	27.0 - 25.5 / 15.6 - 14.8	0.87 - 0.79	245.7 - 252.5 / 142.0 - 146.5	2900-2920

Mains-operated motors, 60 Hz

1 x 220 V, 60 Hz (supply voltage A)

Frame size	P ₂ [kW]	I _{1/1} [A]	Cos φ _{1/1}	I _{start}	Speed [min ⁻¹]
71	0.60	4.1	0.98	8.2	3300
80	0.84	5.8	0.98	18.6	3150
80	1.14	7.4	0.99	19.9	3270
90	1.54	9.8	0.98	37.2	3330

1 x 115/230V, 60 Hz (supply voltage B)

Frame size	P ₂ [kW]	I _{1/1} [A]	Cos φ _{1/1}	I _{start}	Speed [min ⁻¹]
71	0.60	8.1 - 4.26	0.76	21.1 - 11.1	3240
80	0.78	11.0 - 5.6	0.65	33.0 - 16.8	3240
80	1.10	14.2 - 7.2	0.94	45.4 - 23.0	3320
90	1.50	18.8 - 9.8	0.97	75.2 - 39.2	3360

3 x 208-230 V/440-480 V, 60 Hz (supply voltage E)

Frame size	P ₂ [kW]	I _{1/1} [A]	Cos φ _{1/1}	I _{start}	Speed [min ⁻¹]
71	0.43	1.9 - 1.7 / 1.0 - 0.8	0.85 - 0.81 / 0.85 - 0.81	11.0 - 10.0 / 6.2 - 5.2	3360-3420
71	0.74	3.4 - 2.8 / 1.8 - 1.5	0.89 - 0.83 / 0.89 - 0.83	20.1 - 16.5 / 11.4 - 9.5	3220-3370
80	1.04	4.6 - 3.9 / 2.1 - 1.9	0.85 - 0.85 / 0.85 - 0.85	27.1 - 23.0 / 13.7 - 12.1	3220-3340
80	1.28	5.4 - 4.9 / 2.6 - 2.5	0.85 - 0.79 / 0.85 - 0.79	38.9 - 35.3 / 20.8 - 20.0	3380-3430
90	1.70	6.6 - 5.8 / 3.1 - 2.8	0.88 - 0.85 / 0.88 - 0.85	79.4 - 72.1 / 42.8 - 40.5	3490-3520
100	2.52	9.8 - 8.9 / 4.8 - 4.5	0.87 - 0.80 / 0.87 - 0.80	58.8 - 66.8 / 32.3 - 33.8	3470-3500
100	4.00	14.6 - 13.6 / 7.1 - 6.8	0.86 - 0.80 / 0.86 - 0.80	175.2 - 163.2 / 61.8 - 59.2	3520-3530
112	6.20	23.6 - 22.6 / 11.8 - 11.0	0.86 - 0.76 / 0.86 - 0.76	181.7 - 174.0 / 100.3 - 93.5	3490-3510
132	8.30	31.5 - 31.0 / 15.6 - 16.2	0.82 - 0.70 / 0.82 - 0.70	270.9 - 266.6 / 148.2 - 153.9	3520-3530

3 x 575 V, 60 Hz (supply voltage H)

Frame size	P ₂ [kW]	I _{1/1} [A]	Cos φ _{1/1}	I _{start}	Speed [min ⁻¹]
71	0.43	0.70	0.84	4.6	3340
71	0.74	1.20	0.84	7.8	3340
80	1.04	1.70	0.86	11.1	3220
80	1.28	2.10	0.86	16.8	3360
90	1.50	2.40	0.89	21.6	3490
90	2.50	3.70	0.90	27.8	3450
100	4.00	5.50	0.88	47.9	3500
112	6.20	9.10	0.87	77.4	3490
132	8.30	12.50	0.86	118.8	3510

Mains-operated motors, 50/60 Hz

3 x 220-240 V/380-415 V, 50 Hz; 3 x 220-255 V/380-440 V, 60 Hz (supply voltage O)

Frame size	P ₂ [kW]	Frequency [Hz]	I _{1/1} [A]	Cos φ _{1/1}	I _{start}	Speed [min ⁻¹]
71	0.43	50	3.4 - 2.5 / 1.3 - 1.5	0.72 - 0.60	17.0 - 15.0 / 6.5 - 9.0	2870-2890
	0.74	60	3.4 - 2.9 / 1.6 - 1.7	0.87 - 0.84	17.0 - 17.4 / 8.0 - 10.2	3280-3350
80	0.60	50	3.0 - 3.3 / 1.8 - 2.0	0.72 - 0.66	20.1 - 23.1 / 9.0 - 11.8	2870-2870
	1.04	60	3.6 - 3.8 / 2.3 - 2.1	0.87 - 0.84	24.1 - 26.6 / 11.5 - 12.6	3300-3360
80	0.74	50	3.5 - 4.0 / 2.0 - 2.3	0.72 - 0.60	28.4 - 32.0 / 12.7 - 20.7	2890-2910
	1.28	60	4.9 - 4.3 / 2.8 - 2.6	0.90 - 0.84	39.7 - 34.4 / 18.2 - 23.4	3300-3410

3 x 380-415 V, 50 Hz / 3 x 440-480 V, 60 Hz (supply voltage J)

Frame size	P ₂ [kW]	Frequency [Hz]	I _{1/1} [A]	Cos φ _{1/1}	I _{start}	Speed [min ⁻¹]
71	0.25	50	0.7 - 0.5	0.77 - 0.71	4.7 - 3.9	2870-2890
	0.43	60	1.0 - 0.8	0.85 - 0.82	5.6 - 5.2	3360-3420
71	0.43	50	1.1 - 1.3	0.76 - 0.66	6.1 - 7.6	2860-2890
	0.74	60	1.8 - 1.5	0.89 - 0.83	10.4 - 9.5	3220-3380
80	0.57	50	1.3 - 1.1	0.80 - 0.74	8.7 - 7.8	2840-2873
	1.04	60	2.1 - 1.9	0.85 - 0.85	12.4 - 12.1	3220-3340
80	0.74	50	2.0 - 2.2	0.74 - 0.63	14.7 - 17.6	2890-2910
	1.28	60	2.6 - 2.5	0.85 - 0.79	18.7 - 20.0	3380-3430
90	1.00	50	2.3 - 2.1	0.82 - 0.75	26.5 - 25.2	2940-2950
	1.69	60	3.1 - 2.8	0.88 - 0.85	25.1 - 25.2	3490-3520
90	1.45	50	3.5 - 4.0	0.76 - 0.65	30.5 - 36.3	2930-2940
	2.52	60	4.8 - 4.5	0.87 - 0.80	32.3 - 33.8	3470-3500
100	2.40	50	5.5 - 6.0	0.76 - 0.65	65.4 - 80.3	2950-2960
	4.00	60	7.1 - 6.8	0.86 - 0.80	85.2 - 59.2	3520-3530
112	4.20	50	9.1 - 10.8	0.73 - 0.58	78.7 - 99.4	2940-2950
	6.20	60	11.8 - 11.0	0.86 - 0.76	90.9 - 93.5	3490-3510
132	4.80	50	12.6 - 15.2	0.69 - 0.53	119.7 - 152.0	2950-2960
	8.30	60	15.6 - 16.2	0.82 - 0.70	134.2 - 153.9	3520-3530

3 x 200 V/346 V, 50 Hz; 3 x 200-220 V/346-380 V, 60 Hz (supply voltage G)

Frame size	P ₂ [kW]	Frequency [Hz]	I _{1/1} [A]	Cos φ _{1/1}	I _{start}	Speed [min ⁻¹]
71	0.25	50	1.5 / 0.9	0.65	10.6 - 6.2	2900
	0.43	60	2.0 - 1.8 / 1.2 - 1.1	0.85 - 0.80	11.7 - 11.8 / 6.8 - 6.8	3370-3424
71	0.43	50	3.3 / 1.9	0.53	18.2 - 10.5	2904
	0.74	60	3.4 - 3.2 / 1.9 - 1.9	0.83 - 0.76	20.1 - 20.8 / 11.2 - 12.4	3380-3429
80	0.60	50	3.3 / 1.9	0.69	21.8 - 12.7	2882
	1.04	60	4.7 - 4.2 / 2.7 - 2.5	0.86 - 0.84	31.5 - 28.1 / 15.9 - 15.9	3300-3380
80	0.74	50	5.4 / 3.1	0.54	40.5 - 23.3	2900
	1.28	60	5.8 - 5.5 / 3.3 - 3.1	0.85 - 0.79	41.2 - 39.6 / 23.8 - 24.8	3380-3430
90	0.87	50	5.3 / 3.1	0.68	60.4 - 35.7	2950
	1.70	60	6.9 - 6.4 / 4.0 - 3.7	0.88 - 0.85	55.9 - 57.6 / 32.4 - 33.3	3490-3510
90	1.40	50	10.2 / 5.9	0.51	88.7 / 50.9	2950
	2.50	60	10.4 - 10.0 / 6.0 - 5.7	0.87 - 0.79	70.7 - 75.0 / 40.8 - 42.8	3480-3500
100	2.30	50	15.4 / 8.8	0.51	184.8 - 105.6	2960
	4.00	60	15.8 - 15.4 / 9.4 - 8.7	0.86 - 0.79	189.6 - 134.0 / 112.8 - 75.7	3510-3530
112	3.60	50	26.7 / 15.3	0.49	232.3 - 133.1	2950
	6.20	60	24.8 - 25.3 / 14.5 - 14.5	0.85 - 0.76	191.0 - 215.1 / 111.7 - 123.3	3500-3510
132	5.40	50	41.0 / 23.6	0.46	389.5 - 224.2	2950
	8.30	60	34.0 - 35.6 / 19.5 - 20.5	0.83 - 0.70	292.4 - 338.2 / 167.7 - 194.8	3520-3530

3 x 400 V, 50/60 Hz (supply voltage I)

Frame size	P ₂ [kW]	Frequency [Hz]	I _{1/1} [A]	Cos φ _{1/1}	I _{start}	Speed [min ⁻¹]
71	0.25	50	0.8	0.60	6.0	2910
	0.43	60	1.0	0.82	6.5	3400
71	0.43	50	1.4	0.46	7.7	2910
	0.74	60	1.7	0.81	11.1	3400
80	0.60	50	1.9	0.62	12.4	2890
	1.04	60	2.4	0.85	15.6	3340
80	0.74	50	3.4	0.47	25.1	2910
	1.28	60	3.0	0.83	23.6	3480
90	0.87	50	3.1	0.59	35.7	2960
	1.70	60	3.5	0.87	31.5	3510
90	1.40	50	7.3	0.43	63.5	2940
	2.50	60	5.3	0.84	39.8	3490
100	2.30	50	7.6	0.52	91.2	2940
	4.00	60	7.8	0.87	67.9	3520
112	3.60	50	20.0	0.37	174.0	2950
	6.20	60	13.6	0.78	115.6	3510
132	5.40	50	29.5	0.33	280.3	2970
	8.30	60	18.2	0.77	172.9	3530

Speed-controlled motors

1 x 208-230 V, 50/60 Hz (supply voltage M)

Frame size	P ₂ [kW]	I _{1/1} [A]	Cos φ _{1/1}
71	0.55	3.9 - 3.5	0.97
80	1.10	7.5 - 6.6	0.97

1 x 220-240 V, 50/60 Hz (supply voltage K)

Frame size	P ₂ [kW]	I _{1/1} [A]	Cos φ _{1/1}
71	0.55	3.7 - 3.4	0.97
80	1.10	7.1 - 6.6	0.97

3 x 460-480 V, 60 Hz (supply voltage N)

Frame size	P ₂ [kW]	I _{1/1} [A]	Cos φ _{1/1}
90	1.5	2.7 - 2.7	0.87
	2.2	3.7 - 3.7	0.91
112	4.0	6.1 - 6.1	0.92
132	5.5	8.9 - 8.9	0.92

3 x 380-480 V, 50/60 Hz (supply voltage L)

Frame size	P ₂ [kW]	I _{1/1} [A]	Cos φ _{1/1}
90	1.5	3.3 - 2.7	0.91
	2.2	4.6 - 3.8	0.92
100	3.0	6.2 - 5.0	0.94
112	5.5	8.1 - 6.6	0.94
132	5.5	11.0 - 8.8	0.94
132	7.5	15.0 - 12.0	0.94

Additional data for speed-controlled motors

	Single-phase	Three-phase
Electricity supply to pump	1 x 200-240 V – 10 %/+ 10 %, 50/60 Hz, PE.	3 x 380-480 V – 10 %/+ 10 %, 50/60 Hz, PE.
Back-up fuse	Motor sizes of 0.55 to 1.1 kW: Max. 10 A. Standard as well as quick-blow or slow-blow fuses may be used.	Motor sizes of 1.5 to 5.5 kW: Max. 16 A. Motor size 7.5 kW: Max. 32 A. Motor size 11 kW: Max. 25 A. Motor size 15 kW: Max. 35 A. Motor size 18.5 kW: Max. 50 A. Motor size 22 kW: Max. 50 A. Standard as well as quick-blow or slow-blow fuses may be used.
External start/stop input	External potential-free contact. Maximum contact load: Voltage 5 VDC, current < 5 mA. Screened cable*.	
Digital input	External potential-free contact. Maximum contact load: Voltage 5 VDC, current < 5 mA. Screened cable*.	
Setpoint signals	<ul style="list-style-type: none"> Potentiometer 0-10 VDC, 10 kΩ (via internal voltage supply). Screened cable*. Maximum cable length: 100 m. Voltage signal 0-10 VDC, $R_i > 50$ kΩ. Tolerance: + 0 %/– 3 % at maximum voltage signal. Screened cable*. Maximum cable length: 500 m. Current signal DC 0-20 mA/4-20 mA, $R_i = 175$ Ω. Tolerance: + 0 %/– 3 % at maximum current signal. Screened cable*. Maximum cable length: 500 m. 	<ul style="list-style-type: none"> Potentiometer 0-5 VDC, 10 kΩ (via internal voltage supply). Screened cable*. Maximum cable length: 100 m. Voltage signal 0-5 VDC/0-10 VDC, $R_i > 50$ kΩ. Tolerance: + 0 %/– 3 % at maximum voltage signal. Screened cable*. Maximum cable length: 500 m. Current signal DC 0-20 mA/4-20 mA, $R_i = 250$ Ω. Tolerance: + 0 %/– 3 % at maximum current signal. Screened cable*. Maximum cable length: 500 m.
Electricity supply to sensors	The sensors are supplied with electricity via the motor terminal box. <ul style="list-style-type: none"> 24 VDC \pm 10 %. Maximum load: 40 mA. 	The sensors are supplied with electricity via the motor terminal box. <ul style="list-style-type: none"> 24 VDC \pm 10 %. Maximum load: 40 mA.
Sensor signals	<ul style="list-style-type: none"> Voltage signal 0-10 VDC, $R_i > 50$ kΩ. Tolerance: + 0 %/– 3 % at maximum voltage signal. Screened cable*. Maximum cable length: 500 m. Current signal DC 0-20 mA/4-20 mA, $R_i = 175$ Ω. Tolerance: + 0 %/– 3 % at maximum current signal. Screened cable*. Maximum cable length: 500 m. 	<ul style="list-style-type: none"> Voltage signal 0-5 VDC/0-10 VDC, $R_i > 50$ kΩ. Tolerance: + 0 %/– 3 % at maximum voltage signal. Screened cable*. Maximum cable length: 500 m. Current signal DC 0-20 mA/4-20 mA, $R_i = 250$ Ω. Tolerance: + 0 %/– 3 % at maximum current signal. Screened cable*. Maximum cable length: 500 m.
Signal output	Potential-free changeover contact. Maximum contact load: 250 VAC, 2 A. Minimum contact load: 5 VDC, 10 mA. Screened cable: 0.5 - 2.5 mm ² . Maximum cable length: 500 m.	
Bus input	Grundfos bus protocol, GENIbus protocol, RS-485. 0.5 - 1.5 mm ² screened 2-core cable. Maximum cable length: 500 m.	
EMC	EN 61800-3 Note: When pumps fitted with 7.5 kW motors are installed in first environment (residential areas), an additional EMC filter is required to obtain class B, group 1 status. Motors of 0.55 to 5.5 kW: Electromagnetic disturbance – first environment (residential areas) – unrestricted distribution, corresponding to CISPR 11, class B, group 1. Motors of 7.5 kW: Electromagnetic disturbance – first environment (residential areas) – restricted distribution. Immunity to electromagnetic disturbance – second environment (industrial areas) – unrestricted distribution, corresponding to CISPR 11, class A, group 1.	
Enclosure class	IP55 (IEC 34-5).	
Insulation class	F (IEC 85).	
Ambient temperature	During operation: –20 °C to +40 °C. During storage/transport: –40 °C to +60 °C.	
Relative air humidity	Maximum 95 %.	

* Cross section min. 0.5 mm² and max. 1.5 mm².

Pipework connections

Various sets of flanges and couplings are available for pipework connection.

Flange sets for CM(E) (DIN/ANSI/JIS)

All materials in contact with the pumped media are made of stainless steel, EN 1.4408/AISI 316.

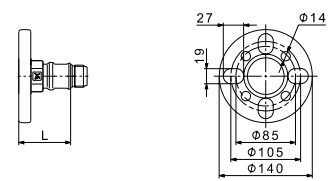
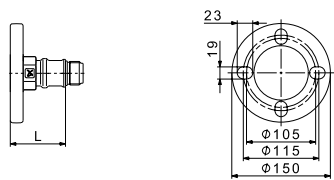
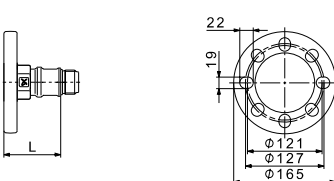
Flange	Pump type	Pipework connection	Pump thread	L* [mm]		Product number	
				Flange mounted on pump inlet	Flange mounted on pump outlet		
	TM04 3867 0309	DN 32	Rp	49.0	78.0	96904693	
			CM 1			NPT	96904705
			CM 3			Rp	96904696
			CM 5			NPT	96904708
	TM04 3869 0309	DN 40	Rp	44.0	68.0	96904699	
			CM 10			NPT	96904711
	TM04 3868 0309	DN 50	Rp	48.0	68.0	96904702	
			CM 15			NPT	96904714

* Length from outer edge of flange to pump suction or discharge port.

Counter flanges for CM(E)-A

Counter flanges for CM(E)-A pumps are made of cast iron, EN-GJL-200.

A counter flange set consists of one counter flange, one gasket, bolts and nuts.

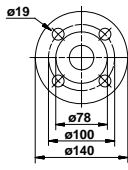
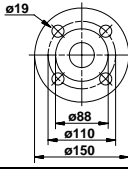
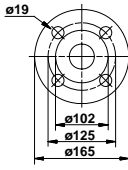
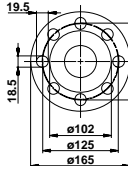
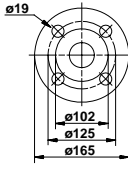
Counter flange	Pump type	Description	Rated pressure	Pipework connection	Product number	
	TM03 0400 3705	CM(E) 1-A CM(E) 3-A CM(E) 5-A	Threaded	16 bar, EN 1092-2	Rp 1 1/4	419901
			For welding	25 bar, EN 1092-2	32 mm, nominal	419902
	TM03 0401 3705	CM(E) 10-A	Threaded	16 bar, EN 1092-2	Rp 1 1/2	429902
			Threaded	16 bar, EN 1092-2	Rp 2	429904
			For welding	25 bar, EN 1092-2	40 mm, nominal	429901
			For welding	40 bar, special flange	50 mm, nominal	429903
	TM03 0402 3705		Threaded	16 bar, EN 1092-2	Rp 2	339903
			Threaded	16 bar, special flange	Rp 2 1/2	339904
	TM02 7203 2803	CM(E) 15-A CM(E) 25-A	Threaded	16 bar, special flange	Rp 2 1/2	96509578
	TM03 0402 3705		For welding	25 bar, EN 1092-2	50 mm, nominal	339901
			For welding	40 bar, special flange	65 mm, nominal	339902

Counter flanges for CM(E)-I/G

Counter flanges for CM(E)-I/G pumps are made of stainless steel, EN 1.4401/AISI 316.

A counter flange set consists of one counter flange, one gasket, bolts and nuts.

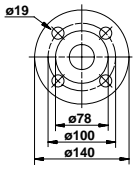
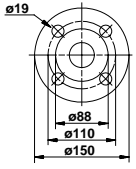
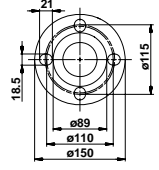
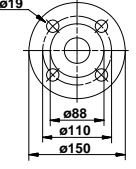
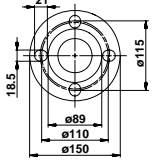
Counter flange	Pump type	Description	Rated pressure	Pipework connection	Product number
	TM03 0400 3705	Threaded	16 bar, EN 1092-2	Rp 1 1/4	415304
		For welding	25 bar, EN 1092-2	32 mm, nominal	415305
	TM03 0401 3705	Threaded	16 bar, EN 1092-2	Rp 1 1/2	425245
	TM02 7202 2803	Threaded	16 bar, EN 1092-2	Rp 2	96509570
	TM03 0401 3705	For welding	25 bar, EN 1092-2	40 mm, nominal	425246
	TM02 7202 2803	For welding	25 bar, special flange	50 mm, nominal	96509571

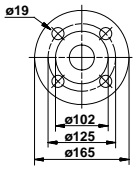
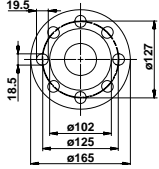
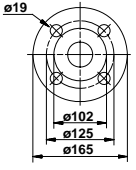
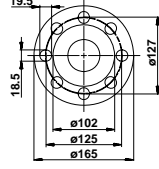
Counter flange	Pump type	Description	Rated pressure	Pipework connection	Product number
	TM00 0402 3705	Threaded	16 bar, EN 1092-2	Rp 2	335254
	TM02 7203 2803	Threaded	16 bar, special flange	Rp 2 1/2	96509575
		Threaded	16 bar, special flange	Rp 2 1/2	96509579
	CM(E) 15-I/G CM(E) 25-I/G				
	TM03 0402 3705	For welding	25 bar, EN 1092-2	50 mm, nominal	335255
	TM00 7203 2803	For welding	25 bar, special flange	65 mm, nominal	96509573

PJE connections for CM(E)

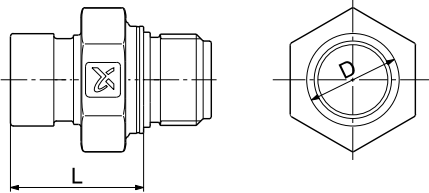
PJE connection	Pump type	Pump thread	D [mm]	L* [mm]	Product number
	CM 1	Rp	33.7	48.5	96904694
	CM 3	NPT			96904706
	CM 5	Rp	42.4	48.5	96904697
		NPT			96904709
	CM 10	Rp	48.3	48.5	96904700
		NPT			96904712
CM 15	Rp	60.3	50.1	96904703	
CM 25	NPT			96904715	

* Length from outer edge of PJE connection to pump suction or discharge port.

Coupling, pipe stub and gasket for PJE connections

Parts in contact with the pumped liquid are made of stainless steel, EN 1.4401/AISI 316, and rubber.

A PJE coupling set consists of two coupling halves (Victaulic, type 77), one gasket, one pipe stub (for welding or threaded), bolts and nuts.

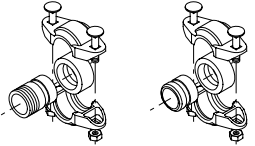
Coupling and pipe stub	Pump type	Pipe stub	PN	Pipework connection	Rubber parts	Number of coupling sets required	Product number
	TM00 3808 1094	Threaded	70 bar	R 2	EPDM	2	339911
					FKM	2	339918
		For welding	70 bar	DN 50	EPDM	2	339910
					FKM	2	339917

Tri-Clamp® connections for CM(E)

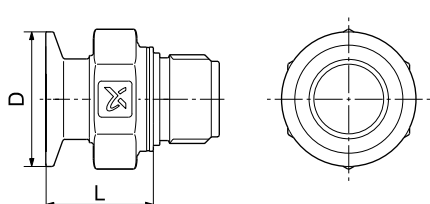
Tri-Clamp®	Pump type	Pump thread	D [mm]	L* [mm]	Product number	
	CM 1	Rp	50.4	40.3	96904695	
	CM 3	NPT			96904707	
	CM 5	Rp	50.4	35.3	96904698	
	CM 10	NPT			96904710	
	CM 15	Rp	63.9	37.4	96904701	
	CM 25	NPT			96904713	
						96904704
						96904716

TM04 3866 0309

* Length from outer edge of Tri-Clamp® connection to pump suction or discharge port.

Clamping ring, pipe stub and gasket for Tri-Clamp® connections

Pump type	Nominal diameter [mm]	Clamping ring		Pipe stub				Gasket	
		A [mm]	B [mm]	A [mm]	B [mm]	C [mm]	D [mm]	A [mm]	B [mm]
CM(E) 1, 3, 5, 10	38.0	92.0	59.5	21.5	50.5	35.6	38.6	35.3	50.5
CM(E) 15, 25	51.0	104.4	74.0	21.5	64.0	48.6	51.6	48.0	64.0

The clamping ring is made of stainless steel, EN 1.4301/AISI 304.

The pipe stub is made of stainless steel, EN 1.4401/AISI 316.

The gasket is made of PTFE or EPDM.

Pump type	Pipework connection	Connection material	Gasket	Pressure [bar]	Number of coupling sets required	Product number
CM(E) 1, 3, 5, 10	DN 32	Stainless steel	EPDM	16	2	96515374
			PTFE		2	96515375
EPDM	2		96515376			
PTFE	2		96515377			
CM(E) 15, 25	DN 50					

Potentiometer for CME

The potentiometer is for setpoint setting and start/stop of the CME pump.

Product	Product number
External potentiometer with cabinet for wall mounting	625468

G10-LON interface for CME

Use the G10-LON interface in connection with data transmission between a Locally Operating Network (LON) and electronically controlled Grundfos pumps applying the Grundfos bus protocol GENIbus.

Product	Product number
G10-LON interface	605726

LiqTec for CM and CME

The LiqTec dry-running protection device protects pump and process against dry-running and temperatures exceeding $130\text{ °C} \pm 5\text{ °C}$. Connected to the motor PTC sensor, LiqTec also monitors the motor temperature.

LiqTec is prepared for DIN rail mounting in control cabinet.

Enclosure class: IPX0.

R100 remote control

Use the R100 for wireless communication with the CME pump. The communication takes place by means of infrared light.

Product	Product number
R100	625333

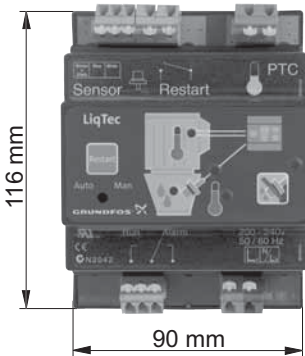
LiqTec dry-running protection	Pump type	Voltage [V]	LiqTec	Sensor, 1/2"	Cable, 5 m	Extension cable, 15 m	Product number
 <p>116 mm</p> <p>90 mm</p> <p>TM03 2108 3705</p>		200-240	●	●	●	–	96556429
	CM(E)	80-130	●	●	●	–	96556430
		–	–	–	–	●	96443676

Sensors for CME

The sensors must be fitted to the pipework with suitable fittings.

Accessory	Type	Supplier	Measuring range	Product number
Flowmeter	SITRANS FM MAGFLO MAG 5100 W	Siemens	1-5 m ³ (DN 25)	ID8285
Flowmeter	SITRANS FM MAGFLO MAG 5100 W	Siemens	3-10 m ³ (DN 40)	ID8286
Flowmeter	SITRANS FM MAGFLO MAG 5100 W	Siemens	6-30 m ³ (DN 65)	ID8287
Flowmeter	SITRANS FM MAGFLO MAG 5100 W	Siemens	20-75 m ³ (DN 100)	ID8288
Temperature sensor	TTA (0) 25	Carlo Gavazzi	0 °C to +25 °C	96432591
Temperature sensor	TTA (-25) 25	Carlo Gavazzi	-25 °C to +25 °C	96430194
Temperature sensor	TTA (50) 100	Carlo Gavazzi	+50 °C to +100 °C	96432592
Temperature sensor	TTA (0) 150	Carlo Gavazzi	0 °C to +150 °C	96430195
Accessory for temperature sensor. All with 1/2 RG connection.	Protecting tube Ø9 x 50 mm	Carlo Gavazzi		96430201
	Protecting tube Ø9 x 100 mm	Carlo Gavazzi		96430202
	Cutting ring bush	Carlo Gavazzi		96430203
Temperature sensor, ambient temperature	WR 52	tmg (Plesner)	-50 °C to +50 °C	ID8295
Differential-temperature sensor	ETSD	Honsberg	0 °C to +20 °C	96409362
Differential-temperature sensor	ETSD	Honsberg	0 °C to +50 °C	96409363

Note: All sensors have 4-20 mA signal output.

Danfoss pressure sensor kits for CM and CME pumps connected to Grundfos CUE

The kit comprises:

- Danfoss pressure transmitter, type MBS 3000, with 2 m screened cable
Connection: G 1/2 A (DIN 16288 - B6kt)
- 5 cable clips (black)
- Installation and operating instructions PT (400212)

Pressure range	Temperature range	Product number
0-4 bar	-40 °C to +85 °C	96428014
0-6 bar		96428015
0-10 bar		96428016
0-16 bar		96428017
0-25 bar		96428018

DPI differential-pressure sensor kit

The kit comprises:

- 1 sensor incl. 0.9 m screened cable (7/16" connections)
- 1 original DPI bracket (for wall mounting)
- 1 Grundfos bracket (for mounting on motor)
- 2 M4 screws for mounting of sensor on bracket
- 1 M6 screw (self-cutting) for mounting on MGE 90/100
- 1 M8 screw (self-cutting) for mounting on MGE 112/132
- 3 capillary tubes (short/long)
- 2 fittings (1/4" - 7/16")
- 5 cable clips (black)
- Installation and operating instructions (480675)
- Service kit instructions

Pressure range	Product number
0 - 0.6 bar	96611522
0 - 1.0 bar	96611523
0 - 1.6 bar	96611524
0 - 2.5 bar	96611525
0 - 4.0 bar	96611526
0 - 6.0 bar	96611527
0 - 10 bar	96611550

MP 204 motor protector



TM03 1471 2205

Fig. 33 MP 204

The MP 204 is an electronic motor protector and data collecting unit. Apart from protecting the motor, it can also send information to a control unit via GENIbus, like for instance:

- trip
- warning
- energy consumption
- input power
- motor temperature.

The MP 204 protects the motor primarily by measuring the motor current by means of a true RMS measurement.

The pump is protected secondarily by measuring the temperature with a Tempcon sensor, a Pt100/Pt1000 sensor and a PTC sensor/thermal switch.

The MP 204 is designed for single- and three-phase motors.

Note: The MP 204 must not be used together with frequency converters.

Features

- Phase-sequence monitoring
- indication of current or temperature
- input for PTC sensor/thermal switch
- indication of temperature in ° C or ° F
- 4-digit, 7-segment display
- setting and status reading with the Grundfos R100 remote control
- setting and status reading via the Grundfos GENIbus fieldbus.

Tripping conditions

- Overload
- underload (dry running)
- temperature
- missing phase
- phase sequence
- overvoltage
- undervoltage
- power factor ($\cos \varphi$)
- current unbalance.

Warnings

- Overload
- underload
- temperature
- overvoltage
- undervoltage
- power factor ($\cos \varphi$)
- run capacitor (single-phase operation)
- starting capacitor (single-phase operation)
- loss of communication in network
- harmonic distortion.

Learning function

- Phase sequence (three-phase operation)
- run capacitor (single-phase operation)
- starting capacitor (single-phase operation)
- identification and measurement of Pt100/Pt1000 sensor circuit.

Product number

Description	Product number
MP 204 motor protection	96079927

Customisation

Although the Grundfos CM and CME product range offers a number of pumps for different applications, customers require specific pump solutions to satisfy their needs. Below are the options available for customising the CM and CME pumps. Contact Grundfos for further information or for requests other than the ones mentioned below.

Motors

Motor with thermal protection	Grundfos offers motors with bimetallic thermal switches or temperature-controlled PTC sensors (thermistors) in the motor windings.
Oversize motor	In installations where one of the conditions mentioned below is present, the motor size must be evaluated to make sure there will be no risk of overload. <ul style="list-style-type: none"> • ambient temperatures above +55 °C • liquid temperatures below 0 °C • installation at altitudes of more than 1000 metres above sea level • use of glycol or other high-viscous liquids. Alternative motors are available on request.
Undersize motor	Available on request.
Use of external frequency converter	For most three-phase CM pumps, a frequency converter supplied by either single- or three-phase supply can be used. In many cases where an external frequency converter is used, it is necessary to protect the motor against voltage peaks higher than 650 V (peak value). Grundfos offers pumps with phase insulation to protect the pump against voltage peaks up to 1000 V (peak values). The supplier of the frequency converter must be consulted to verify the maximum voltage peaks. Grundfos CUE is a suitable frequency converter. See page 28.
Harting plug	Harting plugs are available for easier installation and maintenance of pumps.
Terminal box position	Other terminal box positions are possible for CM pumps with MG 71 and MG 80 motors. CM and CME pumps with motors ranging from 1.1 to 7.5 kW (380-420 V) are available with high-efficiency motors (EFF 1).

High-efficiency motors



These pumps are called premium range. EFF 1 is the highest efficiency class defined by CEMEP (European Committee of Manufacturers of Electrical Machines and Power Electronics).

Pumps

Low-temperature pump	As standard, the CM and CME pumps can be exposed to temperatures down to -20 °C. If required, CM and CME pumps can be delivered in a special variant for pumping liquids at -30 °C. Contact Grundfos.
Alternative discharge port position	The CM and CME pumps can be ordered with alternative discharge port positions, i.e. 3 o'clock and 9 o'clock.
Aggressive liquids	When it is necessary to pump very aggressive liquids, the pump must be fitted with special rubber parts. It is possible to order the pumps with FKM and FFKM rubber parts.

Connections and other variants

Pipe connections	The CM and CME pumps can be ordered with the following pipe connections on request: <ul style="list-style-type: none"> • Tri-Clamp® • DIN flange • ANSI flange • JIS flange • PJE coupling.
-------------------------	--

Certificates and nameplates

Certificates	Certificate of compliance with the order Test certificate Inspection certificate Standard test report ...and many more.
Extra nameplate	Available on request.
UR-marked motor	If the UL-listed product according to UL778 is not available, a pump with UR-marked motor according to UL1004 can be offered as an alternative.

WebCAPS

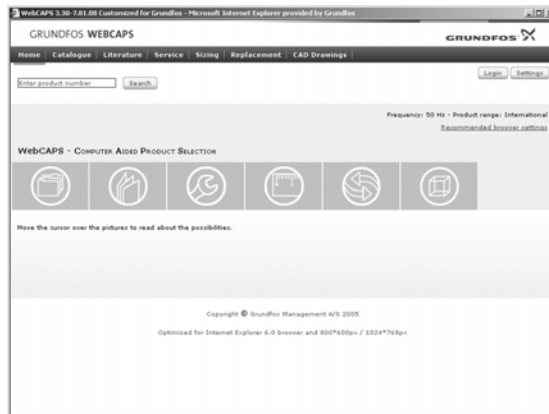

WebCAPS is a **Web-based Computer Aided Product Selection** program available on www.grundfos.com.

WebCAPS contains detailed information on more than 185,000 Grundfos products in more than 20 languages.

In WebCAPS, all information is divided into 6 sections:

- Catalogue
- Literature
- Service
- Sizing
- Replacement
- CAD drawings.



Catalogue

This section is based on fields of application and pump types, and contains

- technical data
- curves (QH, Eta, P1, P2, etc) which can be adapted to the density and viscosity of the pumped liquid and show the number of pumps in operation
- product photos
- dimensional drawings
- wiring diagrams
- quotation texts, etc.

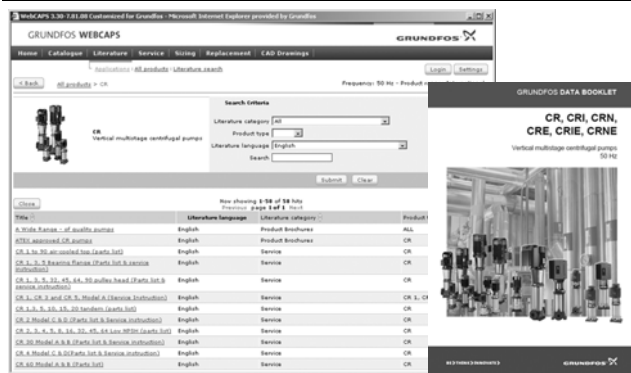

Literature

In this section you can access all the latest documents of a given pump, such as

- data booklets
- installation and operating instructions
- service documentation, such as Service kit catalogue and Service kit instructions
- quick guides
- product brochures.

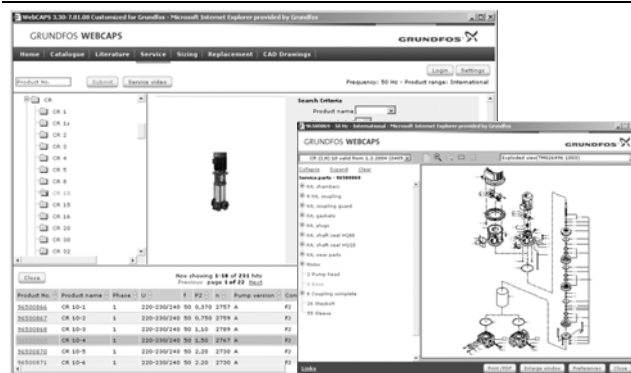

Service

This section contains an easy-to-use interactive service catalogue. Here you can find and identify service parts of both existing and discontinued Grundfos pumps.

Furthermore, this section contains service videos showing you how to replace service parts.



Sizing

This section is based on different fields of application and installation examples, and gives easy step-by-step instructions in how to

- select the most suitable and efficient pump for your installation
- carry out advanced calculations based on energy consumption, payback periods, load profiles, life cycle costs, etc.
- analyse your selected pump via the built-in life cycle cost tool
- determine the flow velocity in wastewater applications, etc.

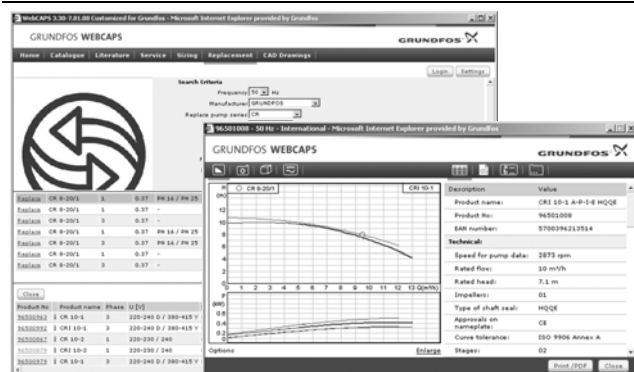

Replacement

In this section you find a guide to selecting and comparing replacement data of an installed pump in order to replace the pump with a more efficient Grundfos pump.

The section contains replacement data of a wide range of pumps produced by other manufacturers than Grundfos.

Based on an easy step-by-step guide, you can compare Grundfos pumps with the one you have installed on your site. When you have specified the installed pump, the guide will suggest a number of Grundfos pumps which can improve both comfort and efficiency.

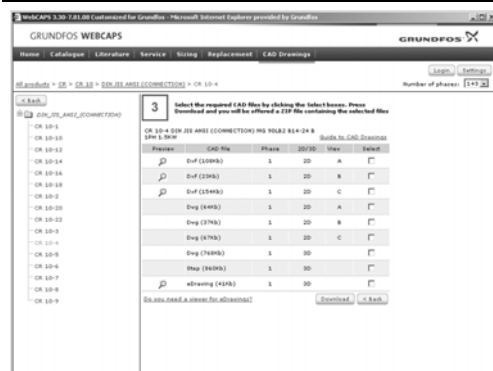

CAD drawings

In this section it is possible to download 2-dimensional (2D) and 3-dimensional (3D) CAD drawings of most Grundfos pumps.

These formats are available in WebCAPS:

- 2-dimensional drawings:
- .dxf, wireframe drawings
 - .dwg, wireframe drawings.
- 3-dimensional drawings:
- .dwg, wireframe drawings (without surfaces)
 - .stp, solid drawings (with surfaces)
 - .eprt, E-drawings.

WinCAPS



Fig. 34 WinCAPS CD-ROM

WinCAPS is a **Windows-based Computer Aided Product Selection** program containing detailed information on more than 185,000 Grundfos products in more than 20 languages.

The program contains the same features and functions as WebCAPS, but is an ideal solution if no Internet connection is available.

WinCAPS is available on CD-ROM and updated once a year.

96903467 0209	GB

Subject to alterations.